

# Programmer Manual



**3066 & 3086**

**3 GHz Real Time Spectrum Analyzer**

**071-0502-01**

This document supports firmware version 2.2.



Copyright © Sony/Tektronix Corporation. All rights reserved.

Copyright © Tektronix, Inc. All rights reserved.

Tektronix products are covered by U.S. and foreign patents, issued and pending. Information in this publication supercedes that in all previously published material. Specifications and price change privileges reserved.

Printed in Japan.

Sony/Tektronix Corporation, P.O.Box 5209, Tokyo Int'l, Tokyo 100-31 Japan

Tektronix, Inc., P.O. Box 1000, Wilsonville, OR 97070-1000

TEKTRONIX and TEK are registered trademarks of Tektronix, Inc.

## WARRANTY

Tektronix warrants that this product will be free from defects in materials and workmanship for a period of one (1) year from the date of shipment. If any such product proves defective during this warranty period, Tektronix, at its option, either will repair the defective product without charge for parts and labor, or will provide a replacement in exchange for the defective product.

In order to obtain service under this warranty, Customer must notify Tektronix of the defect before the expiration of the warranty period and make suitable arrangements for the performance of service. Customer shall be responsible for packaging and shipping the defective product to the service center designated by Tektronix, with shipping charges prepaid. Tektronix shall pay for the return of the product to Customer if the shipment is to a location within the country in which the Tektronix service center is located. Customer shall be responsible for paying all shipping charges, duties, taxes, and any other charges for products returned to any other locations.

This warranty shall not apply to any defect, failure or damage caused by improper use or improper or inadequate maintenance and care. Tektronix shall not be obligated to furnish service under this warranty a) to repair damage resulting from attempts by personnel other than Tektronix representatives to install, repair or service the product; b) to repair damage resulting from improper use or connection to incompatible equipment; or c) to service a product that has been modified or integrated with other products when the effect of such modification or integration increases the time or difficulty of servicing the product.

**THIS WARRANTY IS GIVEN BY TEKTRONIX WITH RESPECT TO THIS PRODUCT IN LIEU OF ANY OTHER WARRANTIES, EXPRESSED OR IMPLIED. TEKTRONIX AND ITS VENDORS DISCLAIM ANY IMPLIED WARRANTIES OF MERCHANTABILITY OR FITNESS FOR A PARTICULAR PURPOSE. TEKTRONIX' RESPONSIBILITY TO REPAIR OR REPLACE DEFECTIVE PRODUCTS IS THE SOLE AND EXCLUSIVE REMEDY PROVIDED TO THE CUSTOMER FOR BREACH OF THIS WARRANTY. TEKTRONIX AND ITS VENDORS WILL NOT BE LIABLE FOR ANY INDIRECT, SPECIAL, INCIDENTAL, OR CONSEQUENTIAL DAMAGES IRRESPECTIVE OF WHETHER TEKTRONIX OR THE VENDOR HAS ADVANCE NOTICE OF THE POSSIBILITY OF SUCH DAMAGES.**



# Table of Contents

## Getting Started

<b>Getting Started</b> .....	<b>1-1</b>
The Difference between the 3066 and 3086 .....	1-1
Overview of the Manual .....	1-2
Connecting the Interface .....	1-4
Using Communication Ports .....	1-5
Setting Communication Parameters from the Front Panel .....	1-7

## Syntax and Commands

<b>Command Syntax</b> .....	<b>2-1</b>
Commands and Queries .....	2-2
Constructed Mnemonics .....	2-6
<b>Command Groups</b> .....	<b>2-7</b>
Functional Groups .....	2-8
General Programming Sequence .....	2-10
Configuration Commands .....	2-11
Setup Commands .....	2-12
View Commands .....	2-14
Utility Commands .....	2-34
<b>Configuration Commands</b> .....	<b>2-37</b>
<b>Standard Setup Commands</b> .....	<b>2-57</b>
<b>CDMA Setup Commands</b> .....	<b>2-77</b>
<b>Waveform View Commands</b> .....	<b>2-91</b>
<b>Analog View Commands</b> .....	<b>2-119</b>
<b>FSK View Commands</b> .....	<b>2-131</b>
<b>Spectrogram View Commands</b> .....	<b>2-141</b>
<b>Waterfall View Commands</b> .....	<b>2-155</b>
<b>Polar View Commands</b> .....	<b>2-171</b>
<b>Eye Diagram View Commands</b> .....	<b>2-187</b>
<b>Symbol Table View Commands</b> .....	<b>2-191</b>
<b>EVM View Commands</b> .....	<b>2-197</b>
<b>CDMA Waveform View Commands</b> .....	<b>2-207</b>
<b>CDMA Polar View Commands</b> .....	<b>2-229</b>
<b>CDMA Time View Commands</b> .....	<b>2-247</b>

<b>CodeSpectrogram View Commands</b> (3066 Option 15 and 3086 Option 16 Only) .....	2-267
<b>CodePolar View Commands</b> (3066 Option 15 and 3086 Option 16 Only) .....	2-277
<b>CodePower View Commands</b> (3066 Option 15 and 3086 Option 16 Only) .....	2-287
<b>CodeWSpectrogram View Commands (3086 Option 16 Only) .....</b>	2-299
<b>CodeWPolar View Commands (3086 Option 16 Only) .....</b>	2-309
<b>CodeWPower View Commands (3086 Option 16 Only) .....</b>	2-319
<b>CCDF Commands (Option 20 Only) .....</b>	2-331
<b>CCDFView Commands (Option 20 Only) .....</b>	2-347
<b>Self Gain-Calibration Commands .....</b>	2-357
<b>Save/Load Commands .....</b>	2-361
<b>Average Commands .....</b>	2-375
<b>Remote Commands .....</b>	2-381
<b>Retrieving Response Message .....</b>	2-399
 <b>Status and Events</b>	
<b>Status and Events .....</b>	3-1
Obtaining Event and Error Messages .....	3-1
TCP/IP Event Port .....	3-1
Status Byte Register (SBR) .....	3-2
Messages .....	3-3
 <b>Programming Examples</b>	
<b>Programming Examples .....</b>	4-1
 <b>Appendices</b>	
<b>Appendix A: Character Charts .....</b>	A-1
<b>Appendix B: Factory Initialization Settings .....</b>	B-1
Configuration Commands .....	B-1
Setup Commands .....	B-2
View Commands .....	B-3
Utility Commands .....	B-15
:Config:Mode Command .....	B-16
 <b>Glossary and Index</b>	

# List of Figures

<b>Figure 1–1: Common message elements</b> .....	1–2
<b>Figure 1–2: Functional groupings and an alphabetical list of commands</b> .....	1–2
<b>Figure 1–3: Event (interrupt) driven programs</b> .....	1–3
<b>Figure 1–4: Example programs of the PERL source codes</b> .....	1–3
<b>Figure 1–5: Interface connector location on the rear panel</b> .....	1–4
<b>Figure 1–6: GPIB connection</b> .....	1–5
<b>Figure 1–7: Typical GPIB network configurations</b> .....	1–5
<b>Figure 1–8: Ethernet connection</b> .....	1–6
<b>Figure 1–9: Setting the communication parameters</b> .....	1–7
<b>Figure 1–10: Setting the GPIB parameters</b> .....	1–8
<b>Figure 1–11: Setting the TCP/IP parameters</b> .....	1–9
<b>Figure 2–1: Example of subsystem hierarchy tree</b> .....	2–2
<b>Figure 2–2: Example of chaining commands and queries</b> .....	2–4
<b>Figure 2–3: Example of omitting root and lower-level nodes in a chained message</b> .....	2–4
<b>Figure 2–4: Settings for burst analysis</b> .....	2–174
<b>Figure 2–5: Setting the mask for the EVM calculation</b> .....	2–202
<b>Figure 2–6: Setting the reference line at 1 MHz of RBW</b> .....	2–216
<b>Figure 2–7: Setting the reference line at 30 kHz of RBW</b> .....	2–218
<b>Figure 2–8: Settings for burst analysis</b> .....	2–232
<b>Figure 2–9: Setting the trigger mask</b> .....	2–256
<b>Figure 2–10: :View&lt;x&gt;:Scale:XStartZero On and Off (example)</b> ...	2–344
<b>Figure 2–10: Data file structure</b> .....	2–361
<b>Figure 2–11: Retrieving response message</b> .....	2–399
<b>Figure 3–1: Obtaining event on the TCP/IP Ethernet</b> .....	3–1
<b>Figure 3–2: The Status Byte Register (SBR)</b> .....	3–2

# List of Tables

<b>Table 2–1: BNF symbols and meanings</b> .....	2–1
<b>Table 2–2: Comparison of header off and on responses</b> .....	2–3
<b>Table 2–3: Parameter types used in syntax descriptions</b> .....	2–3
<b>Table 2–4: Constructed mnemonics</b> .....	2–6
<b>Table 2–5: Functional groups in the command set</b> .....	2–9
<b>Table 2–6: Configuration commands</b> .....	2–11
<b>Table 2–7: Standard Setup commands</b> .....	2–12
<b>Table 2–8: CDMA Setup commands</b> .....	2–13
<b>Table 2–9: Waveform View commands</b> .....	2–14
<b>Table 2–10: Analog View commands</b> .....	2–16
<b>Table 2–11: FSK View commands</b> .....	2–17
<b>Table 2–12: Spectrogram View commands</b> .....	2–18
<b>Table 2–13: Waterfall View commands</b> .....	2–19
<b>Table 2–14: Polar View commands</b> .....	2–20
<b>Table 2–15: Eye Diagram View commands</b> .....	2–21
<b>Table 2–16: Symbol Table View commands</b> .....	2–22
<b>Table 2–17: EVM View commands</b> .....	2–22
<b>Table 2–18: CDMA Waveform View commands</b> .....	2–23
<b>Table 2–19: CDMA Polar View commands</b> .....	2–24
<b>Table 2–20: CDMA Time View commands</b> .....	2–26
<b>Table 2–21: CodeSpectrogram View commands</b> (3066 option 15 and 3086 option 16 only) .....	2–27
<b>Table 2–22: CodePolar View commands</b> (3066 option 15 and 3086 option 16 only) .....	2–28
<b>Table 2–23: CodePower View commands</b> (3066 option 15 and 3086 option 16 only) .....	2–29
<b>Table 2–24: CodeWSpectrogram View commands</b> (3086 option 16 only) .....	2–29
<b>Table 2–25: CodeWPolar View commands (3086 option 16 only)</b> ...	2–30
<b>Table 2–26: CodeWPower View commands (3086 option 16 only)</b> ..	2–31
<b>Table 2–27: CCDF commands (option 20 only)</b> .....	2–32
<b>Table 2–28: CCDFView commands (option 20 only)</b> .....	2–33
<b>Table 2–29: Self Gain-Calibration commands</b> .....	2–34
<b>Table 2–30: Save/Load commands</b> .....	2–34
<b>Table 2–31: Average commands</b> .....	2–35
<b>Table 2–32: Remote commands</b> .....	2–36



<b>Table 3–1: SBR bit functions</b> .....	3–2
<b>Table 3–2: Event message</b> .....	3–3
<b>Table 3–3: No error</b> .....	3–4
<b>Table 3–4: Command error</b> .....	3–4
<b>Table 3–5: Execution error</b> .....	3–4
<b>Table 3–6: Device specific error</b> .....	3–5
<b>Table 3–7: GPIB error</b> .....	3–5
<b>Table A–1: The 3066 character set</b> .....	A–1
<b>Table A–2: ASCII &amp; GPIB code chart</b> .....	A–2
<b>Table B–1: Factory initialization settings — Configuration commands</b> .....	B–1
<b>Table B–2: Factory initialization settings — Setup commands</b> .....	B–2
<b>Table B–3: Factory initialization settings — Waveform View commands</b> .....	B–3
<b>Table B–4: Factory initialization settings — Analog View commands</b> .....	B–4
<b>Table B–5: Factory initialization settings — FSK View commands</b> ..	B–4
<b>Table B–6: Factory initialization settings — Spectrogram View commands</b> .....	B–4
<b>Table B–7: Factory initialization settings — Waterfall View commands</b> .....	B–5
<b>Table B–8: Factory initialization settings — Polar View commands</b>	B–6
<b>Table B–9: Factory initialization settings — Eye diagram View commands</b> .....	B–7
<b>Table B–10: Factory initialization settings — Symbol View commands</b> .....	B–7
<b>Table B–11: Factory initialization settings — EVM View commands</b>	B–7
<b>Table B–12: Factory initialization settings — CDMA Waveform View commands</b> .....	B–8
<b>Table B–13: Factory initialization settings — CDMA Polar View commands</b> .....	B–9
<b>Table B–14: Factory initialization settings — CDMA Time View commands</b> .....	B–9
<b>Table B–15: Factory initialization settings — CodeSpectrogram View commands (3066 option 15 and 3086 option 16 only)</b> .....	B–10
<b>Table B–16: Factory initialization settings — CodePolar View commands (3066 option 15 and 3086 option 16 only)</b> .....	B–11
<b>Table B–17: Factory initialization settings — CodePower View commands (3066 option 15 and 3086 option 16 only)</b> .....	B–11

<b>Table B-18: Factory initialization settings — CodeWSpectrogram View commands (3086 option 16 only)</b>	<b>B-12</b>
<b>Table B-19: Factory initialization settings — CodeWPolar View commands (3086 option 16 only)</b>	<b>B-12</b>
<b>Table B-20: Factory initialization settings — CodeWPower View commands (3086 option 16 only)</b>	<b>B-13</b>
<b>Table B-21: Factory initialization settings — CCDF commands (option 20 only)</b>	<b>B-13</b>
<b>Table B-22: Factory initialization settings — CCDFView commands (option 20 only)</b>	<b>B-14</b>
<b>Table B-23: Factory initialization settings — Self gain-calibration commands</b>	<b>B-15</b>
<b>Table B-24: Factory initialization settings — Save/Load commands</b>	<b>B-15</b>
<b>Table B-25: Factory initialization settings — Average commands</b>	<b>B-15</b>
<b>Table B-26: Factory initialization settings — Remote commands</b>	<b>B-15</b>
<b>Table B-27: Factory initialization settings — :Config:Mode command - 1</b>	<b>B-16</b>
<b>Table B-28: Factory initialization settings — :Config:Mode command - 2</b>	<b>B-17</b>
<b>Table B-29: Factory initialization settings — :Config:Mode command (3066 option 15 and 3086 option 16 only)</b>	<b>B-18</b>
<b>Table B-30: Factory initialization settings — :Config:Mode command (option 20 only)</b>	<b>B-18</b>

# Preface

This is the Programmer Manual for the 3066 and 3086 Real Time Spectrum Analyzer. This manual provides information on operating the instrument over the GPIB and TCP/IP interfaces. It also covers the 3066 Option 15 cdmaOne analysis functions, the 3086 Option 16 W-CDMA/cdmaOne analysis functions, and the 3066/3086 Option 20 CCDF analysis functions.

This manual provides the following information:

- *Getting Started* describes how to connect and set up the analyzer for remote operation.
- *Syntax and Commands* defines the command syntax and processing conventions and describes each command in the analyzer command set.
- *Status and Events* explains the status information and event messages reported by the analyzer.
- *Programming Examples* shows some example analyzer programs.
- *Appendices* contains various tables of reference information.
- *Glossary and Index* contains a glossary of common terms and an index to this manual.

## Related Manuals

Other documentation for the analyzer includes:

- The 3066 and 3086 Real Time Spectrum Analyzer *User Manual* (Tektronix part number 071-0501-XX) describes the operation of the instrument.
- The 3066 and 3086 Real Time Spectrum Analyzer *Service Manual* (Tektronix part number 071-0503-XX) provides information for maintaining and servicing the analyzer.



# Getting Started



# Getting Started

The 3066 and 3086 are DC to 3 GHz Real Time Spectrum Analyzer. The instrument software operates on the Windows 95. You can write computer programs that remotely set the analyzer front panel controls or that take measurements and read those measurements for further analysis or storage through the GPIB or TCP/IP Ethernet (optional) interface.

To help you get started with programming the analyzer, this section includes the following sections:

- *Overview of the Manual* – summarizes the type of programming information contained in each major section of this manual.
- *Setting Up Remote Communications* – describes how to physically connect the analyzer to a controller and set the appropriate front panel controls.

## The Difference between the 3066 and 3086

The 3066 and 3086 functions are the same, except that the 3086 has the following two input modes:

- Wideband input mode: Processes 50 MHz to 3 GHz signals with maximum 30 MHz span in the vector mode.
- IQ input mode: Inputs the I and Q signals directly from the rear panel connectors.

The descriptions in this manual apply to both the 3066 and 3086, unless otherwise noted. For more information about the functions of the analyzer, refer to the *User Manual*.

## Overview of the Manual

The information contained in each major section of this manual is described below.

### Syntax and Commands

The *Syntax and Commands* chapter describes the structure and content of the messages your program sends to the analyzer, Figure 1–1 shows command parts as described in the *Command Syntax* subsection.

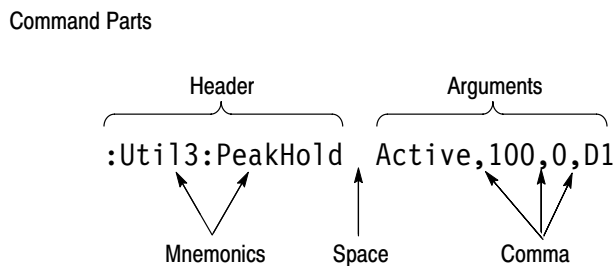

**Figure 1–1: Common message elements**

Chapter 2 also describes the effect of each command and provides examples of how you might use it. The *Command Groups* section provides a list by functional area. The command description sections starting from the *Configuration Commands* on page 2–37 arrange commands alphabetically for each command group (see Figure 1–2).

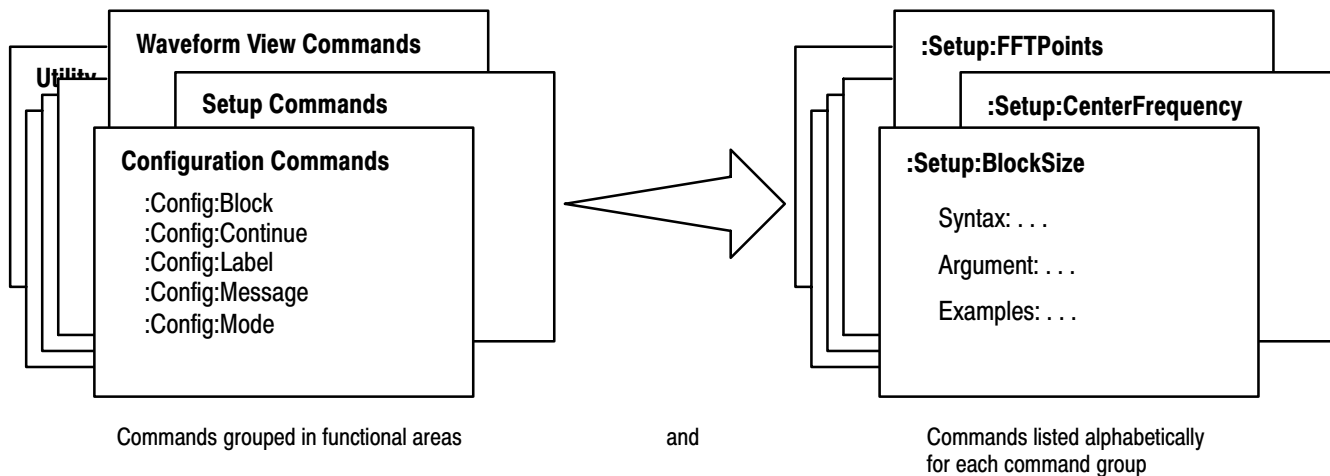

**Figure 1–2: Functional groupings and an alphabetical list of commands**



## Status and Events

The program may request information from the analyzer. The analyzer provides information in the form of status and error messages. Figure 1–3 illustrates the basic operation of this system.

The *Status and Events* chapter starting on page 3–1 describes how to obtain status and event messages in your programs.

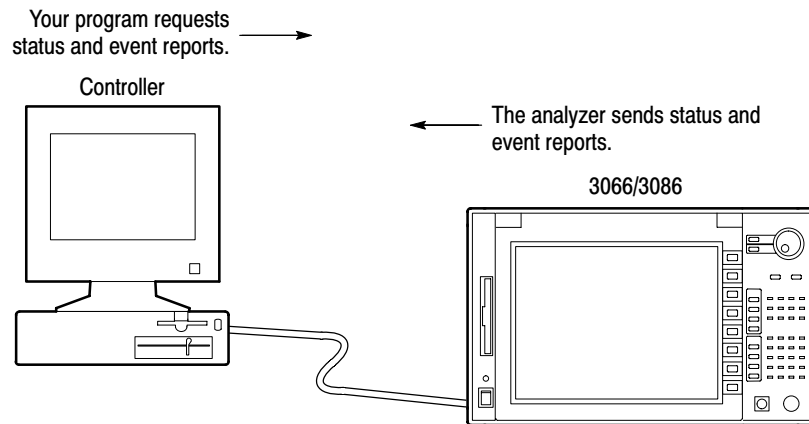

**Figure 1–3: Event (interrupt) driven programs**

## Programming Examples

The *Programming Examples* chapter starting on page 4–1 describes some example programs of the PERL source codes (PERL is a freeware).

```

}

#
# Main
#
tcp_client(S, '', '3000');
tcp_client(SS, '', '3001');
print S "NewLine LF\n";
print S "Config:Pause On\n";
print S "Config:View1 Waveform\n";
print S "View1:Trace2:Source D1\n";
}

```

**Figure 1–4: Example programs of the PERL source codes**

## Connecting the Interface

The analyzer has an IBM PC based expansion slots on its rear panel, as shown in Figure 1–5. The analyzer is shipped standard with a GPIB port. In addition, the analyzer can be configured with optional networking cards.

- **GPIB interface**

This connector has a D-type shell and conforms to IEEE Std 488.1–1987 (The cable is available from Tektronix as part number 012–0991–00).

- **Ethernet interface (Option 10)**

With Option 10, you can connect the analyzer directly to an Ethernet network using a twisted pair (10BASE-T/100BASE-TX) cable.

---

**NOTE.** Only a service personnel can install the network card. Contact Tektronix for details.

---

You can also connect the following peripheral devices to the analyzer. Refer to the *3066 and 3086 User Manual* for information on using these interfaces.

- Mouse and keyboard interface
- Parallel interface for connecting a printer
- SCSI interface for connecting a SCSI device such as an hard disk.

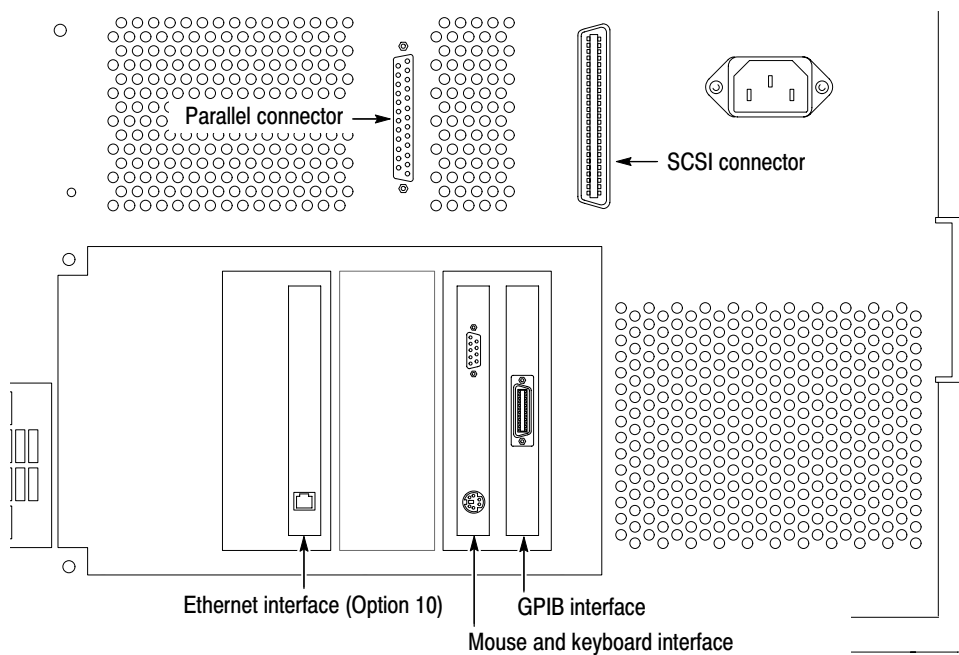

**Figure 1–5: Interface connector location on the rear panel**

## Using Communication Ports

The analyzer can communicate with the external controller or other devices on the GPIB and Ethernet network.

### Using the GPIB

The analyzer has the Talker/Listener and Controller functions. Refer to the next section about setting the parameters for the port.

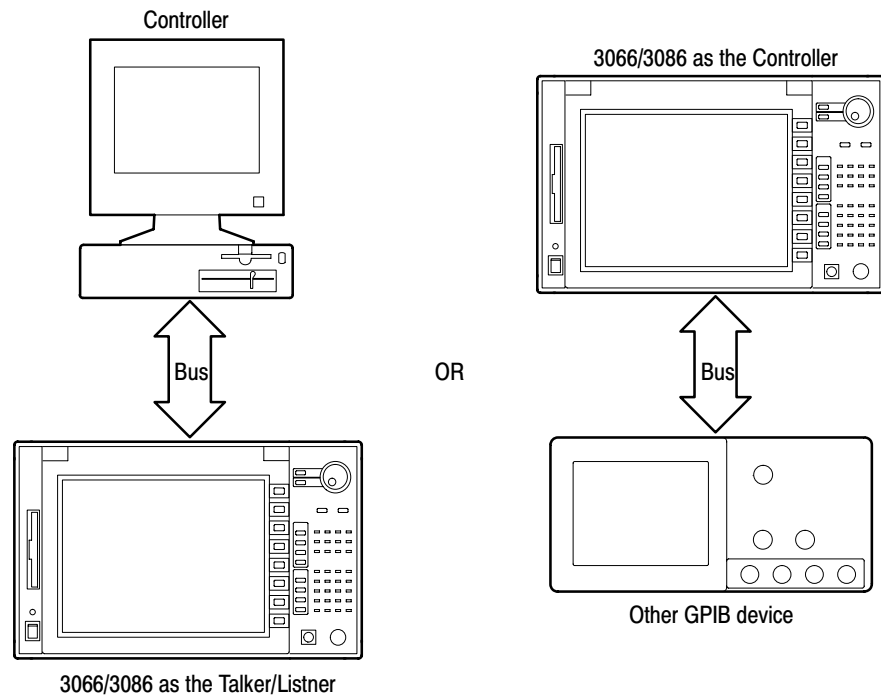

**Figure 1-6: GPIB connection**

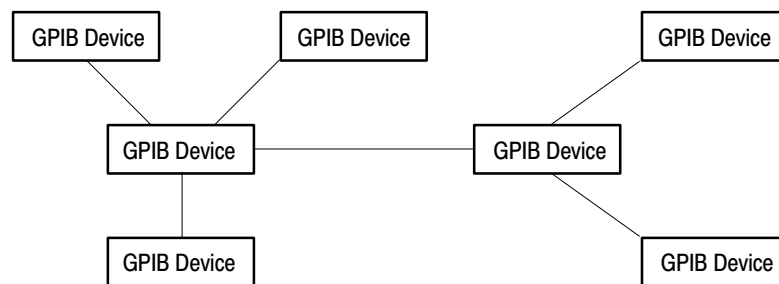

**Figure 1-7: Typical GPIB network configurations**

**GPIO Requirements.** Observe these rules when you use your analyzer with a GPIO network:

- Assign a unique device address to each device on the bus. No two devices can share the same device address.
- Do not connect more than 15 devices to any one bus.
- Connect one device for every 2 meters (6 feet) of cable used.
- Do not use more than 20 meters (65 feet) of cable to connect devices to a bus.
- Turn on at least two-thirds of the devices on the network while using the network.
- Connect the devices on the network in a star or linear configuration. Do not use loop or parallel configurations (see Figure 1–7).

### Using TCP/IP

The analyzer communicates with the external devices through the following two ports on the TCP/IP Ethernet network.

- **Command port** receives commands from, or returns responses to the external controller.
- **Event port** sends events to the external controller.

Refer to the next section about setting the parameters for these ports.

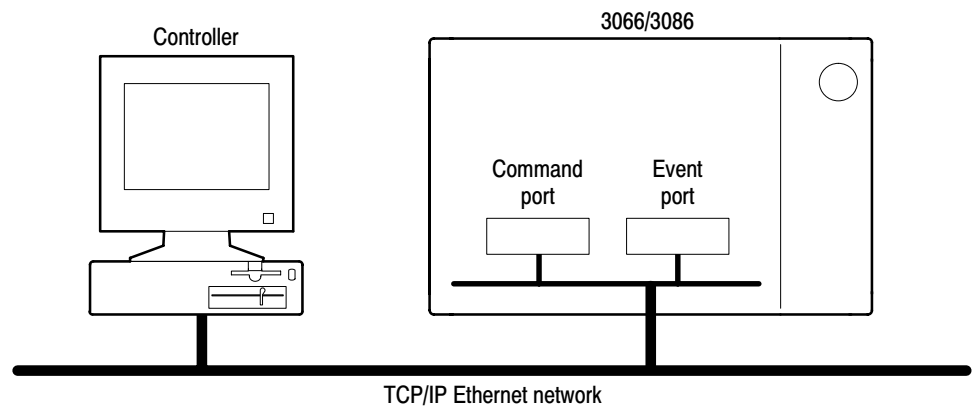

**Figure 1-8: Ethernet connection**

## Setting Communication Parameters from the Front Panel

You can set the communication parameters from the front panel menu or with the Remote commands. This section describes the front panel operation procedures. For the remote control commands, refer to *Remote Commands* on page 2–381.

1. Press the **CONFIG:UTILITY** key to display the Utility menu.
2. Press the **MORE...** side key.
3. Press the **UTIL H** side key to display the Remote menu. See Figure 1–9.
  - If you use the GPIB interface, go to the next section *Setting the GPIB Parameters* on page 1–8.
  - If you use the TCP/IP interface, go to the section *Setting the TCP/IP Parameters* on page 1–9.

UNCAL					OVERLOAD					TRIGGERED					PAUSE									
																				[Util H] Remote				
																				GPIB...				
																				TCP/IP...				

**Figure 1–9: Setting the communication parameters**

### Setting the GPIB Parameters

You need to set the GPIB parameters of the analyzer to match the configuration of the bus. Once you have set these parameters, you can control the analyzer through the GPIB interface.

1. Press the **GPIB** side key to display the GPIB configuration menu. See Figure 1–10.
2. Press the **Interface** side key, and select **Talker/Listener** using either the general purpose knob or the keypad.
3. Press the **Primary Address** side key, and set GPIB address using either the general purpose knob or the keypad.

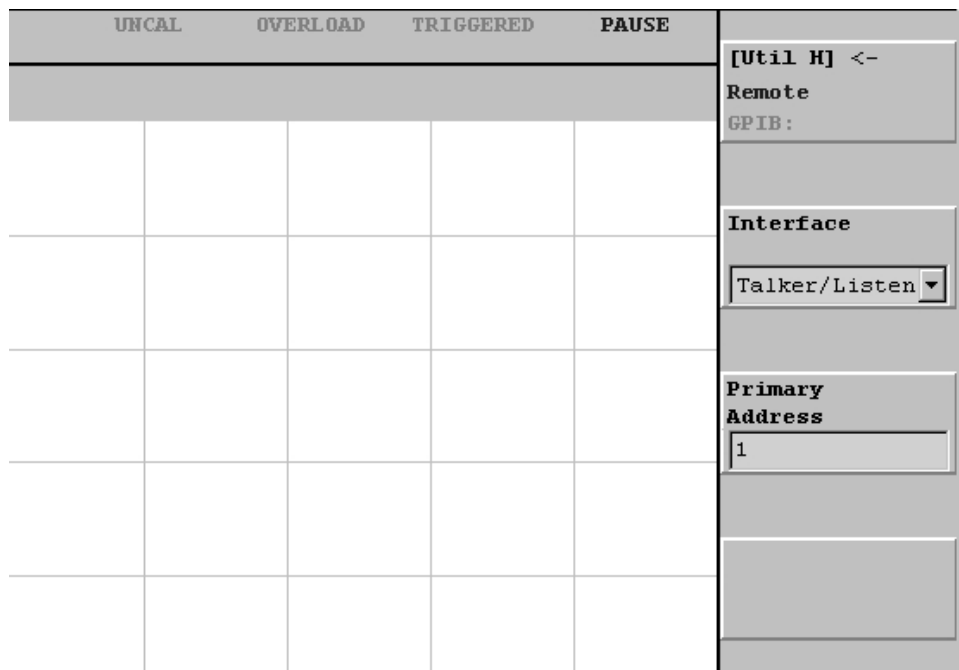

**Figure 1–10: Setting the GPIB parameters**

The analyzer is set up for bidirectional communication with your controller. If you wish to isolate the analyzer from the bus:

- Press the **Interface** side key, and select **Off** using either the general purpose knob or the keypad.

## Setting the TCP/IP Parameters

You need to set the TCP/IP parameters of the analyzer to match the network configuration. Once you have set these parameters, you can control the analyzer on the Ethernet network.

1. Press the **TCP/IP** side key to display the TCP/IP configuration menu. See Figure 1–11.
2. Press the **Command Port** side key, and set the command port number using either the general purpose knob or the keypad. The number ranges 1024 to 32767.
3. Press the **Event Port** side key, and set the event port number using either the general purpose knob or the keypad. The number ranges 1024 to 32767. It must be different from the command port number.
4. Press the **New Line** side key, and select the new-line character of returned value using either the general purpose knob or the keypad.

UNCAL	OVERLOAD	TRIGGERED	PAUSE	
				[Util H] <- Remote TCP/IP:
				Command Port 3000
				Event Port 3001
				Reset...
				New Line CRLF

Figure 1–11: Setting the TCP/IP parameters





# Syntax and Commands



# Command Syntax

This section contains general information on command structure and syntax usage. You should familiarize yourself with this material before using the analyzer command descriptions.

This manual describes commands and queries using the Backus-Naur Form (BNF) notation. Table 2–1 defines the standard BNF symbols.

**Table 2-1: BNF symbols and meanings**

Symbol	Meaning
< >	Defined element
::=	Is defined as
	Exclusive OR
{ }	Group; one element is required
[ ]	Optional; can be omitted
. . .	Previous element(s) may be repeated
( )	Comment

## Commands and Queries

The analyzer commands are based on a hierarchical or tree structure (see Figure 2–1) that represents a subsystem. The top level of the tree is the root node; it is followed by one or more lower-level nodes.

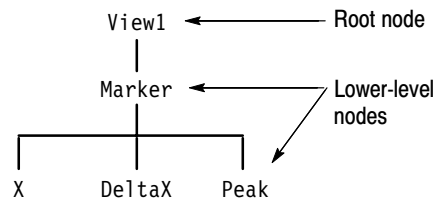

**Figure 2–1: Example of subsystem hierarchy tree**

You can create commands and queries from these subsystem hierarchy trees. Commands specify actions for the instrument to perform. Queries return measurement data and information about parameter settings.

### Creating Commands

The analyzer commands are created by stringing together the nodes of a subsystem hierarchy and separating each node by a colon (:).

In Figure 2–1, View1 is the root node and Marker, X, DeltaX, and Peak are lower-level nodes. To create a command, start with the root node View1 and move down the tree structure adding nodes until you reach the end of a branch. Most commands and some queries have parameters; you must include a value for these parameters. The command descriptions, which start on page 2–7, list the valid values for all parameters.

For example, `:View1:Marker:X 1.5` is a valid command created from the hierarchy tree in Figure 2–1.

---

**NOTE.** *If you specify a parameter value that is out of range, the parameter will be set to a default value.*

---

### Creating Queries

To create a query, start at the root node of a tree structure, move down to the end of a branch, and add a question mark. `:View1:Marker:X?` is an example of a valid query using the hierarchy tree in Figure 2–1.

## Headers in Query Responses

You can control whether the analyzer returns headers as part of the query response. Use the [:Util8]:Header command (page 2–386) to control this feature. If header is on, the query response returns command headers and formats itself as a valid set command. When header is off, the response includes only the values. This may make it easier to parse and extract the information from the response. Table 2–2 shows the difference in responses.

**Table 2–2: Comparison of header off and on responses**

Query	Header off response	Header on response
:View1:Source?	"FILE1.AP"	:View1:Source "File1.AP"
:Setup:Span?	5M	:Setup:Span 5M

## Parameter Types

Parameters are indicated by angle brackets, such as <file\_name>. There are several different types of parameters, as listed in Table 2–3. The parameter type is listed after the parameter. Some parameter types are defined specifically for the analyzer command set and some are defined by ANSI/IEEE 488.2-1987.

**Table 2–3: Parameter types used in syntax descriptions**

Parameter Type	Description	Example
boolean	Boolean numbers or values	On, Off
discrete	A list of specific values	MIN, MAX
NR1 <sup>1</sup> numeric	Integers	0, 1, 15, -1
NR2 <sup>1</sup> numeric	Decimal numbers	1.2, 3.141516, -6.5
NR3 <sup>1</sup> numeric	Floating point numbers	3.1415E-9, -16.1E5
NRf <sup>1</sup> numeric	Flexible decimal number that may be type NR1, NR2, or NR3	See NR1, NR2, NR3 examples
string <sup>2</sup>	Alphanumeric characters (must be within quotation marks)	"Testing 1, 2, 3"

**1** An ANSI/IEEE 488.2-1992-defined parameter type.

**2** Defined in ANSI/IEEE 488.2 as "String Response Data" and "String Program Data."

## Special Characters

The Line Feed (LF) character (ASCII 10) and all characters in the range of ASCII 127-255 are defined as special characters. Using these characters in any command yields unpredictable results.

**Abbreviating Commands, Queries, and Parameters**

You must not abbreviate all commands, queries, and parameters. For example, shortening the command `:Setup:CenterFrequency` to `:Setup:CenterFreq` causes an error.

**Chaining Commands and Queries**

You can chain several commands or queries together into a single message. To create a chained message, first create a command or query, then add a semicolon (;), and finally add more commands or queries and semicolons until you are done. If the command following a semicolon is a root node, precede it with a colon (:). Figure 2–2 illustrates a chained message consisting of several commands and queries. The chained message should end in a command or query, not a semicolon. Responses to any queries in your message are separated by semicolons.

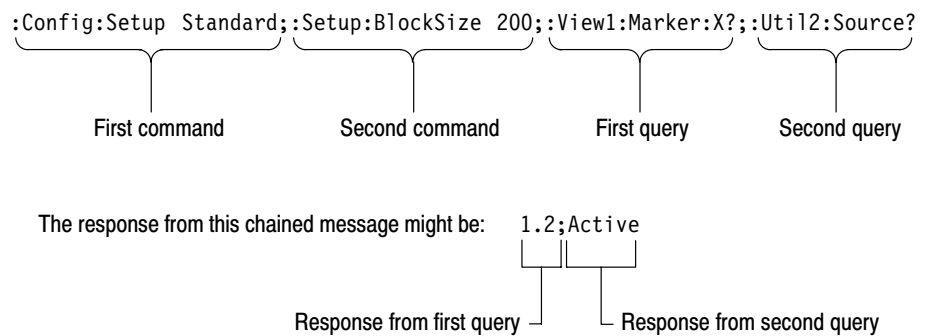

**Figure 2-2: Example of chaining commands and queries**

If a command or query has the same root and lower-level nodes as the previous command or query, you can omit these nodes. In Figure 2–3, the second command has the same root node (Marker) as the first command, so these nodes can be omitted.

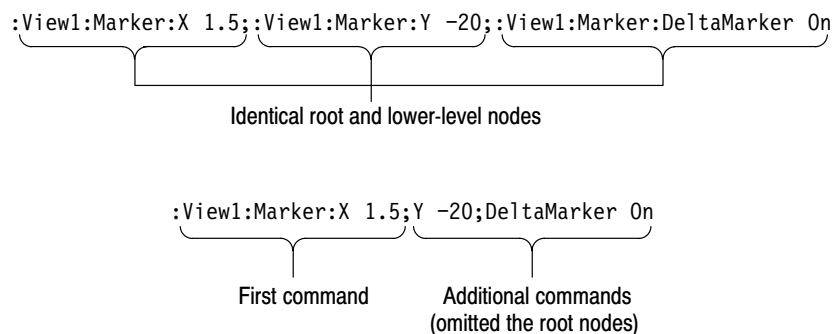

**Figure 2-3: Example of omitting root and lower-level nodes in a chained message**

**Unit and SI Prefix**

If a decimal numeric argument refers to amplitude, frequency, or time, you can express it using SI units instead of the scaled explicit point input value format <NR3>. (SI units conform to the Systeme International d'Unites standard.) For example, you can use the input format 200 m or 1.0 M instead of 200.0E-3 or 1.0E+6, respectively, to specify the argument.

---

**NOTE.** You must omit the unit, such as Hz and dB. For example, 5 MHz of frequency is represented by “5M” in a command.

---

The SI prefixes, which must be included, are shown below. Note that either lower or upper case prefixes can be used.

SI prefix	p/P	n/N	u/U	m/M	k/K	M/M	G/G
Corresponding power	10 <sup>-12</sup>	10 <sup>-9</sup>	10 <sup>-6</sup>	10 <sup>-3</sup>	10 <sup>3</sup>	10 <sup>6</sup>	10 <sup>9</sup>

\* Note that the prefix m/M indicates 10<sup>-3</sup> when the decimal numeric argument denotes amplitude or time, but 10<sup>6</sup> when it denotes frequency.

**General Rules**

Here are three general rules for using the analyzer commands, queries, and parameters:

- You must use double (“ ”) quotation marks for quoted strings.

correct: “This string uses quotation marks correctly.”

incorrect: ‘This string also uses quotation marks correctly.’

incorrect: “This string does not use quotation marks correctly.’

- You can use upper case, lower case, or a mixture of both cases for all commands, queries, and parameters.

:VIEW1:MASK:RBW1M:FREQUENCY 25M

is the same as

:view1:mask:rbw1m:frequency 25m

and

:view1:mask:rbw1m:FREQUENCY 25M

- No embedded spaces are allowed between or within nodes.

correct: :VIEW1:MASK:RBW1M:FREQUENCY 25M

incorrect: :VIEW1: MASK: RBW1M: FREQ UENCY 25M

## Constructed Mnemonics

Some header mnemonics specify one of a range of mnemonics. For example, a view mnemonic can be either `View1`, `View2`, ... or `View8`. You use these mnemonics in the command just as you do any other mnemonic. For example, there is a `View1:Format` command, and there is also a `View2:Format` command. In the command descriptions, this list of choices is abbreviated as `View<x>`.

**Table 2-4: Constructed mnemonics**

Symbol	Meaning
<code>View&lt;x&gt;</code>	A view specifier where <code>&lt;x&gt;</code> = 1 to 8, corresponding to A - H
<code>Utility&lt;x&gt;</code>	A utility specifier where <code>&lt;x&gt;</code> = 1 to 8, corresponding to A - H
<code>Dev&lt;x&gt;</code>	A GPIB device where <code>&lt;x&gt;</code> is the GPIB address
<code>Result&lt;x&gt;</code>	A result specifier where <code>&lt;x&gt;</code> ranges 1 to 26, depending on commands
<code>&lt;address&gt;</code>	GPIB address, ranging 1 to 30
<code>&lt;command&gt;</code>	IEEE 488.2 command e.g. *IDN
<code>&lt;message&gt;</code>	Specify the message for the command
<code>&lt;item&gt;</code>	Specify the item for the command



# Command Groups

The following sections list the 3066 and 3086 spectrum analyzer commands in two ways. They first present them by functional groups, then list them alphabetically. The functional group lists start below. The alphabetical lists provide more detail on each command and start on page 2–37.

Items followed by question marks are queries; items without question marks are commands. Some items in this section have a question mark in parentheses (?) in the command header section; this indicates that the item can be both a command and a query.

## Functional Groups

There are four main groups:

- **Configuration** command group configures the analyzer for the specific measurement. Also, it starts or stops data acquisition.
- **Setup** command group sets up the analyzer hardware, such as frequency, span, trigger, and memory.
- **View** command group displays waveform and performs measurement.
- **Utility** command group controls the utilities, such as self calibration, file management, averaging, and remote operation.

Table 2–5 lists the functional groups and subgroups of the commands. The analyzer has its system program modules corresponding to each subgroup.

**Table 2-5: Functional groups in the command set**

<b>Group</b>	<b>Subgroup</b>	<b>Description</b>
Configuration	–	Configure the analyzer and start/stop acquisition
Setup	Standard	Set up the analyzer for the standard measurement
	CDMA	Set up the analyzer for the CDMA measurement
View	Waveform	Control the Waveform view
	Analog	Control the Analog view
	FSK	Control the FSK view
	Spectrogram	Control the Spectrogram view
	Waterfall	Control the Waterfall view
	Polar	Control the Polar view
	Eye diagram	Control the Eye diagram view
	Symbol table	Control the Symbol table view
	EVM	Control the EVM view
	CDMA Waveform	Control the CDMA Waveform view
	CDMA Polar	Control the CDMA Polar view
	CDMA Time	Control the CDMA Time view
	CodeSpectrogram	<sup>1</sup> Control the code-domain spectrogram view (cdmaOne standard)
	CodePolar	<sup>1</sup> Control the polar view (cdmaOne standard)
	CodePower	<sup>1</sup> Control the code-domain power view (cdmaOne standard)
	CodeWSpectrogram	<sup>2</sup> Control the code-domain spectrogram view (W-CDMA standard)
	CodeWPolar	<sup>2</sup> Control the polar view (W-CDMA standard)
	CodeWPower	<sup>2</sup> Control the code-domain power view (W-CDMA standard)
	CCDF	<sup>3</sup> Control the CCDF measurement
CCDFView	<sup>3</sup> Control the CCDF view	
Utility	Self gain-calibration	Control the self gain-calibration
	Save/Load	Control to save and load data to/from files
	Average	Control averaging
	Remote	Control remote operation

<sup>1</sup> 3066 option 15 and 3086 option 16 only.

<sup>2</sup> 3086 option 16 only.

<sup>3</sup> 3066/3086 option 20 only.

## General Programming Sequence

The programs for controlling the analyzer have the following steps in general:

1. *Configuration:* Use the Configuration command group to set the basic operation mode and assign the Views.

Also, use the Remote command subgroup (Util8) to set the communication parameters with other device.

2. *Setup:* Use the Setup command group to set the hardware, such as frequency, span, trigger, and memory.
3. *Acquisition:* Use the Configuration command group to start or stop the waveform acquisition.

You can load previously acquired data with the Save/Load command subgroup (Util2).

4. *Measurement and Display:* Use the View command group to measure and display the result. For example, if you have selected the Spectrogram View in the configuration, use the Spectrogram View command subgroup.

You can use the Average command subgroup (Util3) to average waveforms. Also, you can save the data to a file with the Save/Load command subgroup (Util2).

Section 4, *Programming Examples* shows some example programs.

Powering on the analyzer initializes its settings to the factory defaults. For the details about the factory defaults, refer to *Appendix B: Factory Initialization Settings*.

## Configuration Commands

These commands configure the system. These commands are equivalent to the **CONFIG** and **START/STOP** menu on the front panel.

**Table 2-6: Configuration commands**

Header	Description
:Config:Block	Start or stop data acquisition in the Block mode
:Config:Continue	Continue the data acquisition
:Config:Label	Display a label on the screen
:Config:Message	Display a message in red on the screen
:Config:Mode	Load settings from the basic configuration file
:Config:Mode:Load	Load settings from a file saved before
:Config:Mode:Save	Save settings to a file
:Config:Next	Stop and restart a block data acquisition
:Config:Pause (?)	Pause the data acquisition on each block
:Config:PrintScreen	Print a screen image to a printer
:Config:PrintScreen:Printer (?)	Specify the printer to print screen images
:Config:PrintScreen:Items?	Return the list of available printers
:Config:PrintScreen:Save	Save a screen image to a file
:Config:Roll	Start or stop the data acquisition in the Roll mode
:Config:Setup (?)	Load the Setup program for the SETUP menu
:Config:Setup:Items?	Return the list of available programs for the setup
:Config:Setup:Show	Display the CONFIG:SETUP menu
:Config:Start	Start a data acquisition in the Block mode
:Config:StartAgain	Stop and restart the acquisition in the Block mode
:Config:Status:Overload?	Query the overload status of the A/D converter
:Config:Status:Pause?	Query if the data acquisition pauses
:Config:Status:Triggered?	Query if the analyzer is triggered
:Config:Status:Uncal?	Query if the analyzer is uncalibrated
:Config:Stop	Stop the data acquisition
:Config:System?	Query the instrument name
:Config:Util:Items?	Return the list of available programs for the utility
:Config:Util<x> (?)	Assign the Utility program to a Utility side key
:Config:Util<x>:Show	Display the CONFIG:UTILITY menu
:Config:Version?	Query the version of the Configuration program

**Table 2-6: Configuration commands (Cont.)**

Header	Description
:Config:View:BackgroundColor (?)	Select the background color for waveform view area
:Config:View:Items?	Return the list of available programs for the view
:Config:View:MarkerLink (?)	Determine whether the markers in different views move in unison or separately
:Config:View:Style (?)	Select the view layout
:Config:View<x> (?)	Assign the View program to a View side key
:Config:View<x>:Show	Display the View menu

## Setup Commands

### Standard Setup Commands

When you select Standard in the Config:Setup command, use the following commands to control parameters for the standard measurement. These commands are equivalent to the **SETUP** menu on the front panel.

**Table 2-7: Standard Setup commands**

Header	Description
:Setup:BlockSize (?)	Set the number of frames per block
:Setup:CenterFrequency (?)	Set the center frequency
:Setup:FFTPoints (?)	Set the number of FFT sampling points per frame
:Setup:FFTWindow (?)	Select the FFT window
:Setup:FramePeriod (?)	Set the frame period in the Block mode
:Setup:FrequencyOffset (?)	Set the frequency display offset
:Setup:InputCoupling (?)	Select the input coupling to the RF input
:Setup:InputMode (?)	Select the signal input mode
:Setup:LevelOffset (?)	Set the level display offset
:Setup:Load	Load a trigger mask from a file
:Setup:MarkerToFreq	Set the center frequency to the value at the marker
:Setup:MaxSpan	Set the span to the maximum
:Setup:MemoryMode (?)	Select the memory mode
:Setup:ReferenceLevel (?)	Set the reference level
:Setup:ReferenceOsc (?)	Select the reference oscillator
:Setup:Save	Save a trigger mask to a file

**Table 2-7: Standard Setup commands (Cont.)**

Header	Description
:Setup:Span (?)	Select the span
:Setup:Trigger (?)	Select the trigger mode
:Setup:TriggerCount (?)	Turn the trigger counter on or off
:Setup:TriggerDelayed (?)	Set the delay time in the Delayed trigger mode
:Setup:TriggerDomain (?)	Select the trigger domain
:Setup:TriggerInterval (?)	Set the time interval in the Interval trigger mode
:Setup:TriggerPosition (?)	Set the trigger position
:Setup:TriggerSlope (?)	Select the trigger slope
:Setup:TriggerSource (?)	Select the trigger source
:Setup:TriggerTimeout (?)	Set the timeout in the Timeout trigger mode
:Setup:TriggerTimes (?)	Set the trigger count in the Count trigger mode
:Setup:Version?	Query the version of the Setup program
:Setup:Zoom:Execute	Expand the waveform
:Setup:Zoom:Frequency (?)	Set the center frequency for zooming
:Setup:Zoom:Mag (?)	Select the magnification factor for zooming

**CDMA Setup Commands**

When you select CDMA in the `Config:Setup` command, use the following commands to control parameters for the CDMA measurement. These commands are equivalent to the **SETUP** menu on the front panel.

**Table 2-8: CDMA Setup commands**

Header	Description
:Setup:BlockSize (?)	Set the number of frames per block
:Setup:CDMA:Channel (?)	Select the channel
:Setup:CDMA:Span30M	Set the span to 30 MHz
:Setup:CDMA:Span50M	Set the span to 50 MHz
:Setup:CDMA:Span5MAuto	Set the span to 5 MHz and the trigger mode to Auto
:Setup:CDMA:Span5MNormal	Set the span to 5 MHz and the trigger mode to Normal
:Setup:CDMA:Standard (?)	Select the CDMA standard
:Setup:CDMA:TriggerLevel (?)	Set the trigger mask level in the time domain
:Setup:MarkerToFreq	Set the center frequency to the value at the marker

**Table 2–8: CDMA Setup commands (Cont.)**

Header	Description
:Setup:MaxSpan	Set the span to the maximum
:Setup:ReferenceLevel (?)	Set the reference level
:Setup:ReferenceOsc (?)	Select the reference oscillator
:Setup:Span (?)	Select the span
:Setup:Trigger (?)	Select the trigger mode
:Setup:TriggerCount (?)	Turn the trigger counter on or off
:Setup:TriggerDelayed (?)	Set the delay time in the Delayed trigger mode
:Setup:TriggerDomain (?)	Select the trigger domain
:Setup:TriggerInterval (?)	Set the time interval in the Interval trigger mode
:Setup:TriggerPosition (?)	Set the trigger position in a block
:Setup:TriggerSlope (?)	Select the trigger slope
:Setup:TriggerSource (?)	Select the trigger source
:Setup:TriggerTimeout (?)	Set the timeout in the Timeout trigger mode
:Setup:TriggerTimes (?)	Set the trigger count in the Count trigger mode
:Setup:Version?	Query the version of the CDMA Setup program

## View Commands

### Waveform View Commands

These commands control the Waveform view.

**Table 2–9: Waveform View commands**

Header	Description
:View<x>:Average:Times (?)	Set the number of frames for averaging
:View<x>:Average:Type (?)	Select the average type
:View<x>:Compression (?)	Select the way to compress data for displaying
:View<x>:CopyFrom	Copy display data from a text file to the data register
:View<x>:CopyTo	Copy display data to a file or data register
:View<x>:Edit (?)	Determine whether or not to display the trigger mask
:View<x>:Edit:DrawHorizontal	Draw the entire trigger mask line horizontally through the marker
:View<x>:Edit:DrawLine	Draw the trigger mask line between the marker and the delta marker



**Table 2-9: Waveform View commands (Cont.)**

<b>Header</b>	<b>Description</b>
:View<x>:Edit:DrawMax	Draw the entire trigger mask line horizontally at the maximum level
:View<x>:Edit:DrawMin	Draw the entire trigger mask line horizontally at the minimum level
:View<x>:Edit:Y (?)	Set the vertical position of the marker in editing the trigger mask
:View<x>:Format (?)	Select the waveform display format
:View<x>:Marker:Band:Center (?)	Set the center frequency of the band marker
:View<x>:Marker:Band:Left (?)	Set the left side frequency of the band marker
:View<x>:Marker:Band:Right (?)	Set the right side frequency of the band marker
:View<x>:Marker:Band:Width (?)	Set the bandwidth of the band marker
:View<x>:Marker:DeltaMarker (?)	Turn on or off the delta marker
:View<x>:Marker:DeltaX (?)	Set the horizontal position of the delta marker
:View<x>:Marker:DeltaY?	Query the vertical position of the delta marker
:View<x>:Marker:Peak	Move the marker to the adjacent peak
:View<x>:Marker:ResetDelta	Move the delta marker to the marker position
:View<x>:Marker:SearchMax	Search the maximum peak and place the marker on it
:View<x>:Marker:SearchMin	Search the minimum peak and place the marker on it
:View<x>:Marker:SearchSeparation (?)	Set the resolution to separate two peaks
:View<x>:Marker:Trace (?)	Select the trace on which the markers are placed
:View<x>:Marker:X (?)	Set the horizontal position of the marker
:View<x>:Marker:Y?	Query the vertical position of the marker
:View<x>:MaskVisible (?)	Specify whether or not to display the trigger mask
:View<x>:Measurement (?)	Select the measurement item
:View<x>:Measurement:ACP:BW (?)	Set the bandwidth for the ACP measurement
:View<x>:Measurement:ACP:Marker (?)	Select the marker position for the ACP measurement
:View<x>:Measurement:ACP:SP (?)	Set the frequency interval between adjacent channels for the ACP measurement
:View<x>:Measurement:OBW (?)	Set the occupied bandwidth
:View<x>:Position (?)	Set the display position in a block
:View<x>:Result<y>?	Query the measurement results
:View<x>:Scale:AutoScale	Scale the vertical axis automatically
:View<x>:Scale:HoldYScale (?)	Determine whether to hold or reset the vertical scale when you change the input source

**Table 2-9: Waveform View commands (Cont.)**

Header	Description
:View<x>:Scale:XScale (?)	Scale the horizontal axis
:View<x>:Scale:XStart (?)	Set the start point of the horizontal axis on the screen
:View<x>:Scale:YScale (?)	Scale the vertical axis
:View<x>:Scale:YStart (?)	Set the start point of the vertical axis on the screen
:View<x>:Source (?)	Select the input data source
:View<x>:Trace2:Compression (?)	Select the compression method to display the trace 2
:View<x>:Trace2:Format (?)	Select the display format of the trace 2
:View<x>:Trace2:Source (?)	Select the input data source of the trace 2
:View<x>:Trace2:Z (?)	Set the frame number of the trace 2
:View<x>:Version?	Query the version of the Waveform View program
:View<x>:Z (?)	Set the frame number

**Analog View Commands**

These commands control the Analog view to analyze an analog modulating signal. This view is capable of demodulating and displaying PM (Phase Modulation), AM (Amplitude Modulation), or FM (Frequency Modulation) signals.

**Table 2-10: Analog View commands**

Header	Description
:View<x>:CopyTo	Copy display data to a file or data register
:View<x>:Format (?)	Select the waveform display format
:View<x>:Marker:DeltaMarker (?)	Turns on or off the delta marker
:View<x>:Marker:DeltaX (?)	Query the horizontal position of the delta marker
:View<x>:Marker:DeltaY?	Query the vertical position of the delta marker
:View<x>:Marker:Peak	Move the marker to the adjacent peak
:View<x>:Marker:ResetDelta	Move the delta marker to the marker position
:View<x>:Marker:SearchMax	Search the maximum peak and place the marker on it
:View<x>:Marker:SearchMin	Search the minimum peak and place the marker on it
:View<x>:Marker:SearchSeparation (?)	Set the resolution to separate two peaks
:View<x>:Marker:X (?)	Set the horizontal position of the marker
:View<x>:Marker:Y?	Query the vertical position of the marker
:View<x>:Scale:AutoScale	Scale the vertical axis automatically

**Table 2-10: Analog View commands (Cont.)**

Header	Description
:View<x>:Scale:HoldYScale (?)	Determine whether to hold or reset the vertical scale when you change the input source
:View<x>:Scale:XScale (?)	Scale the horizontal axis
:View<x>:Scale:XStart (?)	Set the start point of the horizontal axis on the screen
:View<x>:Scale:YScale (?)	Scale the vertical axis
:View<x>:Scale:YStart (?)	Set the start point of the vertical axis on the screen
:View<x>:Source (?)	Select the input data source
:View<x>:Version?	Query the version of the Analog View program
:View<x>:Z (?)	Set the frame number

**FSK View Commands**

These commands control the FSK view. In this view, the FSK (Frequency Shift Keying) signal is demodulated and displayed.

**Table 2-11: FSK View commands**

Header	Description
:View<x>:CopyTo	Copy display data to a file or data register
:View<x>:Marker:DeltaMarker (?)	Turns on or off the delta marker
:View<x>:Marker:DeltaX (?)	Set the horizontal position of the delta marker
:View<x>:Marker:DeltaY?	Query the vertical position of the delta marker
:View<x>:Marker:Peak	Move the marker to the adjacent peak
:View<x>:Marker:ResetDelta	Move the delta marker to the marker position
:View<x>:Marker:SearchMax	Search the maximum peak and place the marker on it
:View<x>:Marker:SearchMin	Search the minimum peak and place the marker on it
:View<x>:Marker:SearchSeparation (?)	Set the resolution to separate two peaks
:View<x>:Marker:X (?)	Set the horizontal position of the marker
:View<x>:Marker:Y?	Query the vertical position of the marker
:View<x>:Scale:AutoScale	Scale the vertical axis automatically
:View<x>:Scale:HoldYScale (?)	Determine whether to hold or reset the vertical scale when you change the input source
:View<x>:Scale:XScale (?)	Scale the horizontal axis
:View<x>:Scale:XStart (?)	Set the start point of the horizontal axis on the screen
:View<x>:Scale:YScale (?)	Scale the vertical axis
:View<x>:Scale:YStart (?)	Set the start point of the vertical axis on the screen

**Table 2-11: FSK View commands (Cont.)**

Header	Description
:View<x>:Source (?)	Select the input data source
:View<x>:Version?	Query the version of the FSK View program
:View<x>:Z (?)	Set the frame number

## Spectrogram View Commands

These commands control the Spectrogram view.

**Table 2-12: Spectrogram View commands**

Header	Description
:View<x>:Compression (?)	Select the way to compress data for displaying
:View<x>:Format (?)	Select the waveform display format
:View<x>:Marker:DeltaMarker (?)	Turn the delta marker on or off
:View<x>:Marker:DeltaT?	Query the delta marker position on the time axis
:View<x>:Marker:DeltaX (?)	Set the horizontal position of the delta marker
:View<x>:Marker:DeltaY?	Query the vertical position of the delta marker
:View<x>:Marker:DeltaZ (?)	Set the delta marker position on the Z axis
:View<x>:Marker:Peak	Move the marker to the adjacent peak
:View<x>:Marker:ResetDelta	Move the delta marker to the marker position
:View<x>:Marker:SearchMax	Search the maximum peak and place the marker on it
:View<x>:Marker:SearchMin	Search the minimum peak and place the marker on it
:View<x>:Marker:SearchSeparation (?)	Set the resolution to separate two peaks
:View<x>:Marker:T?	Query the marker position on the time axis
:View<x>:Marker:X (?)	Set the horizontal position of the marker
:View<x>:Marker:Y?	Query the vertical position of the marker
:View<x>:Marker:Z (?)	Set the marker position on the Z axis
:View<x>:Monochrome (?)	Set the display to monochrome
:View<x>:NumberColors (?)	Select the number of display colors
:View<x>:Scale:AutoScale	Scale the vertical axis automatically
:View<x>:Scale:HoldYScale (?)	Determine whether to hold or reset the vertical scale when you change the input source
:View<x>:Scale:XScale (?)	Scale the horizontal axis
:View<x>:Scale:XStart (?)	Set the start point of the horizontal axis on the screen
:View<x>:Scale:YScale (?)	Scale the vertical axis

**Table 2-12: Spectrogram View commands (Cont.)**

Header	Description
:View<x>:Scale:YStart (?)	Set the start point of the vertical axis on the screen
:View<x>:Scale:ZScale (?)	Scale the Z axis
:View<x>:Scale:ZStart (?)	Set the start point of the Z axis on the screen
:View<x>:Source (?)	Select the input data source
:View<x>:Version?	Query the version of the Spectrogram View program
:View<x>:ZGap (?)	Set the interval between two frames on the Z axis

**Waterfall View Commands**

These commands control the Waterfall view.

**Table 2-13: Waterfall View commands**

Header	Description
:View<x>:Compression (?)	Select the way to compress data for displaying
:View<x>:Format (?)	Select the waveform display format
:View<x>:Marker:DeltaMarker (?)	Turn the delta marker on or off
:View<x>:Marker:DeltaT?	Query the delta marker on the time axis
:View<x>:Marker:DeltaX (?)	Set the horizontal position of the delta marker
:View<x>:Marker:DeltaY?	Query the vertical position of the delta marker
:View<x>:Marker:DeltaZ (?)	Set the delta marker position on the Z axis
:View<x>:Marker:Peak	Move the marker to the adjacent peak
:View<x>:Marker:ResetDelta	Move the delta marker to the marker position
:View<x>:Marker:SearchMax	Search the maximum peak and place the marker on it
:View<x>:Marker:SearchMin	Search the minimum peak and place the marker on it
:View<x>:Marker:SearchSeparation (?)	Set the resolution to separate two peaks
:View<x>:Marker:T?	Query the marker position on the time axis
:View<x>:Marker:X (?)	Set the horizontal position of the marker
:View<x>:Marker:Y?	Query the vertical position of the marker
:View<x>:Marker:Z (?)	Set the marker position on the Z axis
:View<x>:Scale:AutoScale	Scale the vertical axis automatically
:View<x>:Scale:HoldYScale (?)	Determine whether to hold or reset the vertical scale when you change the input source
:View<x>:Scale:XScale (?)	Scale the horizontal axis
:View<x>:Scale:XStart (?)	Set the start point of the horizontal axis on the screen

**Table 2–13: Waterfall View commands (Cont.)**

Header	Description
:View<x>:Scale:YScale (?)	Scale the vertical axis
:View<x>:Scale:YStart (?)	Set the start point of the vertical axis on the screen
:View<x>:Scale:ZScale (?)	Scale the Z axis
:View<x>:Scale:ZStart (?)	Set the start point of the Z axis on the screen
:View<x>:Source (?)	Select the input data source
:View<x>:Version?	Query the version of the Waterfall View program
:View<x>:YHeight (?)	Specify the number of pixels of vertical full-scale
:View<x>:ZGap (?)	Set interval between adjacent Z axes on the screen

**Polar View Commands**

These commands control the Polar view.

**Table 2–14: Polar View commands**

Header	Description
:View<x>:AlphaBT (?)	Set the $\alpha$ /BT
:View<x>:AutoCarrier (?)	Turn on or off the carrier search function
:View<x>:Burst:BlockSize (?)	Set the range for searching a burst
:View<x>:Burst:NumberFrames (?)	Set the range for acquiring burst data
:View<x>:Burst:Offset (?)	Set the start point for acquiring burst data
:View<x>:Burst:Search (?)	Determine whether to search a burst
:View<x>:Burst:Threshold (?)	Set the threshold to detect the rising edge of a burst
:View<x>:Carrier (?)	Set the carrier frequency
:View<x>:Display (?)	Select the display data source
:View<x>:Format (?)	Select the waveform display format
:View<x>:Marker:A?	Query the amplitude at the marker position
:View<x>:Marker:DeltaT (?)	Set the delta marker position on the time axis
:View<x>:Marker:P?	Query the phase at the marker position
:View<x>:Marker:T (?)	Set the marker position on the time axis
:View<x>:Marker:X?	Query the horizontal position of the marker
:View<x>:Marker:Y?	Query the vertical position of the marker
:View<x>:MeasDestination (?)	Select the data register to which the measurement data is output
:View<x>:MeasFilter (?)	Select the filter for the measurement data

**Table 2-14: Polar View commands (Cont.)**

Header	Description
:View<x>:Modulation (?)	Select the modulation type
:View<x>:Position (?)	Set display position in a block
:View<x>:RefDestination (?)	Select the data register to which the reference data is output
:View<x>:RefFilter (?)	Select the filter for the reference data
:View<x>:Result<y>?	Query the measurement results
:View<x>:Source (?)	Select the input data source
:View<x>:Standard:CDPD	Set parameters according to the CDPD standard
:View<x>:Standard:GSM	Set parameters according to the GSM standard
:View<x>:Standard:NADC	Set parameters according to the NADC standard
:View<x>:Standard:PDC	Set parameters according to the PDC standard
:View<x>:Standard:PHS	Set parameters according to the PHS standard
:View<x>:Standard:TETRA	Set parameters according to the TETRA standard
:View<x>:SymbolRate (?)	Set the symbol rate
:View<x>:Version?	Query the version of the Polar View program
:View<x>:Z (?)	Set the frame number

### Eye Diagram View Commands

These commands control the Eye Diagram view.

**Table 2-15: Eye Diagram View commands**

Header	Description
:View<x>:EyeLength (?)	Set the number of symbols on the horizontal axis
:View<x>:Format (?)	Select the waveform display format
:View<x>:Marker:T (?)	Set the marker position on the time axis
:View<x>:Marker:Y?	Query the vertical position of the marker
:View<x>:Source (?)	Select the input data source
:View<x>:Version?	Query the version of the Eye Diagram View program

## Symbol Table View Commands

These commands control the Symbol Table view.

**Table 2-16: Symbol Table View commands**

Header	Description
:View<x>:CopyTo	Copy display data to the clipboard
:View<x>:Marker:Data?	Query the value at the marker position
:View<x>:Marker:Symbol?	Query the symbol location where the marker is placed
:View<x>:Marker:T (?)	Set the marker position on the time axis
:View<x>:Radix (?)	Select the radix to display the Symbol Table
:View<x>:Rotate (?)	Set the reference phase
:View<x>:Source (?)	Select the input data source
:View<x>:Symbol (?)	Set the symbol location where the marker is placed
:View<x>:Version?	Query the version of the Symbol Table View program

## EVM View Commands

These commands control the EVM (Error Vector Magnitude) view.

**Table 2-17: EVM View commands**

Header	Description
:View<x>:CopyTo	Copy display data to a file or data register
:View<x>:Format (?)	Select the waveform display format
:View<x>:Marker:DeltaMarker (?)	Turn the delta marker on or off
:View<x>:Marker:DeltaX (?)	Set the horizontal position of the delta marker
:View<x>:Marker:DeltaY?	Query the vertical position of the delta marker
:View<x>:Marker:ResetDelta	Move the delta marker to the marker position
:View<x>:Marker:SearchMax	Search the maximum peak and place the marker on it
:View<x>:Marker:SearchMin	Search the minimum peak and place the marker on it
:View<x>:Marker:X (?)	Set the horizontal position of the marker
:View<x>:Marker:Y?	Query the vertical position of the marker
:View<x>:MaskArea (?)	Set the area to exclude from calculating EVM
:View<x>:Result<y>?	Query the measurement results
:View<x>:Scale:AutoScale	Scale the vertical axis automatically
:View<x>:Scale:XScale (?)	Scale the horizontal axis
:View<x>:Scale:XStart (?)	Set the start point of the horizontal axis on the screen
:View<x>:Scale:YScale (?)	Scale the vertical axis



**Table 2-17: EVM View commands (Cont.)**

Header	Description
:View<x>:Scale:YStart (?)	Set the start point of the vertical axis on the screen
:View<x>:Symbol (?)	Set the symbol location where the marker is placed
:View<x>:Version?	Query the version of the EVM View program

### CDMA Waveform View Commands

These commands control the CDMA Waveform view.

**Table 2-18: CDMA Waveform View commands**

Header	Description
:View<x>:Average:Times (?)	Set the number of frames for averaging
:View<x>:Average:Type (?)	Select the average type
:View<x>:CDMA:Channel (?)	Select the channel
:View<x>:CDMA:Standard (?)	Select the CDMA standard
:View<x>:Compression (?)	Select the way to compress data for displaying
:View<x>:CopyFrom	Copy display data from a text file to data register
:View<x>:CopyTo	Copy display data to a file or data register
:View<x>:Format (?)	Select the waveform display format
:View<x>:Marker:DeltaMarker (?)	Turn on or off the delta marker
:View<x>:Marker:DeltaX (?)	Set the horizontal position of the delta marker
:View<x>:Marker:DeltaY?	Query the vertical position of the delta marker
:View<x>:Marker:Peak	Move the marker to the adjacent peak
:View<x>:Marker:ResetDelta	Move the delta marker to the marker position
:View<x>:Marker:SearchMax	Search the maximum peak and place the marker on it
:View<x>:Marker:SearchMin	Search the minimum peak and place the marker on it
:View<x>:Marker:SearchSeparation (?)	Set the resolution to separate two peaks
:View<x>:Marker:X (?)	Set the horizontal position of the marker
:View<x>:Marker:Y?	Query the vertical position of the marker
:View<x>:Mask:RBW1M:Frequency (?)	Set frequency of the reference line at 1 MHz RBW
:View<x>:Mask:RBW1M:Level (?)	Set level of the reference line at 1 MHz RBW
:View<x>:Mask:RBW30k:Frequency1 (?)	Set the inner frequency of the reference line at 30 kHz RBW
:View<x>:Mask:RBW30k:Frequency2 (?)	Set the outer frequency of the reference line at 30 kHz RBW

**Table 2–18: CDMA Waveform View commands (Cont.)**

Header	Description
:View<x>:Mask:RBW30k:Level1 (?)	Set the inner level of the reference line at 30 kHz RBW
:View<x>:Mask:RBW30k:Level2 (?)	Set the outer level of the reference line at 30 kHz RBW
:View<x>:Measurement (?)	Select the measurement function
:View<x>:Measurement:OBW (?)	Set the occupied bandwidth
:View<x>:Measurement:Separation (?)	Set the spurious resolution
:View<x>:Measurement:SortedBy (?)	Select the sort key of spurious
:View<x>:Measurement:Spurious-Search	Turn the spurious search function on or off
:View<x>:Measurement:Threshold (?)	Set the threshold for the spurious search
:View<x>:Position (?)	Set the display position in a block
:View<x>:RBW (?)	Set the resolution bandwidth
:View<x>:Result<y>?	Query the measurement results
:View<x>:Scale:AutoScale	Scale the vertical axis automatically
:View<x>:Scale:HoldYScale (?)	Determine whether to hold or reset the vertical scale when you change the input source
:View<x>:Scale:XScale (?)	Scale the horizontal axis
:View<x>:Scale:XStart (?)	Set the start point of the horizontal axis on the screen
:View<x>:Scale:YScale (?)	Scale the vertical axis
:View<x>:Scale:YStart (?)	Set the start point of the vertical axis on the screen
:View<x>:Source (?)	Select the input data source
:View<x>:Version?	Query the version of the CDMA Waveform View program
:View<x>:Z (?)	Set the frame number

### CDMA Polar View Commands

These commands control the CDMA Polar view.

**Table 2–19: CDMA Polar View commands**

Header	Description
:View<x>:AlphaBT (?)	Set the $\alpha$ /BT
:View<x>:AutoCarrier (?)	Turn the carrier search function on or off
:View<x>:Burst:BlockSize (?)	Set the range for searching a burst
:View<x>:Burst:NumberFrames (?)	Set the range for acquiring burst data

**Table 2–19: CDMA Polar View commands (Cont.)**

<b>Header</b>	<b>Description</b>
:View<x>:Burst:Offset (?)	Set the start point for acquiring burst data
:View<x>:Burst:Search (?)	Determine whether to search a burst
:View<x>:Burst:Threshold (?)	Set the threshold to detect the rising edge of a burst
:View<x>:Carrier (?)	Set the carrier frequency
:View<x>:Display (?)	Select the display data source
:View<x>:Format (?)	Select the waveform display format
:View<x>:Marker:A?	Query the amplitude at the marker position
:View<x>:Marker:DeltaT (?)	Set the delta marker position on the time axis
:View<x>:Marker:P?	Query the phase at the marker position
:View<x>:Marker:T (?)	Set the marker position on the time axis
:View<x>:Marker:X?	Query the horizontal position of the marker
:View<x>:Marker:Y?	Query the vertical position of the marker
:View<x>:MeasDestination (?)	Select the data register to which the measurement data is output
:View<x>:MeasFilter (?)	Select the filter for the measurement data
:View<x>:Modulation (?)	Select the modulation type
:View<x>:Position (?)	Set the display position in a block
:View<x>:RefDestination (?)	Select the data register to which the reference data is output
:View<x>:RefFilter (?)	Select the filter for the reference data
:View<x>:Result<y>?	Query the measurement results
:View<x>:Source (?)	Select the input data source
:View<x>:Standard:CDPD	Set parameters according to the CDPD standard
:View<x>:Standard:GSM	Set parameters according to the GSM standard
:View<x>:Standard:IS95	Set parameters according to the IS-95 standard
:View<x>:Standard:NADC	Set parameters according to the NADC standard
:View<x>:Standard:PDC	Set parameters according to the PDC standard
:View<x>:Standard:PHS	Set parameters according to the PHS standard
:View<x>:Standard:TETRA	Set parameters according to the TETRA standard
:View<x>:SymbolRate (?)	Set the symbol rate
:View<x>:Version?	Query the version of the CDMA Polar View program
:View<x>:Z (?)	Set the frame number

## CDMA Time View Commands

These commands control the CDMA Time view.

**Table 2-20: CDMA Time View commands**

Header	Description
:View<x>:Average:Times (?)	Set the number of frames for averaging
:View<x>:Block (?)	Set the block number
:View<x>:BreakMeasure	Stop executing the Measure function
:View<x>:BreakMeasureData	Stop executing the Measure Data function
:View<x>:Executing?	Query the operation status of the Measure or MeasureData command
:View<x>:Marker:DeltaMarker (?)	Turn the delta marker on or off
:View<x>:Marker:DeltaX (?)	Set the horizontal position of the delta marker
:View<x>:Marker:DeltaY?	Query the vertical position of the delta marker
:View<x>:Marker:Peak	Move the marker to the adjacent peak
:View<x>:Marker:ResetDelta	Move the delta marker to the marker position
:View<x>:Marker:SearchMax	Search the maximum peak and place the marker on it
:View<x>:Marker:SearchMin	Search the minimum peak and place the marker on it
:View<x>:Marker:SearchSeparation (?)	Set the resolution to separate two peaks
:View<x>:Marker:X (?)	Set the horizontal position of the marker
:View<x>:Marker:Y?	Query the vertical position of the marker
:View<x>:Mask:OffLeft (?)	Set the reference time just before the rising edge
:View<x>:Mask:OffLevel (?)	Set the reference off-level
:View<x>:Mask:OffRight (?)	Set the reference time just after the falling edge
:View<x>:Mask:OnLeft (?)	Set the reference time after rising edge
:View<x>:Mask:OnLevel (?)	Set the reference on-level
:View<x>:Mask:OnRight (?)	Set the reference time just before the falling edge
:View<x>:Measure	Average newly acquired data and perform PASS/FAIL test
:View<x>:MeasureData	Average data on the memory and perform PASS/FAIL test
:View<x>:Position (?)	Set the display position in a block
:View<x>:Result<y>?	Query measurement results
:View<x>:Scale:FallingEdge	Expand the falling edge of waveform on the screen
:View<x>:Scale:FullScale	Display the whole waveform
:View<x>:Scale:HoldYScale (?)	Determine whether to hold or reset the vertical scale when you change the input source

**Table 2–20: CDMA Time View commands (Cont.)**

Header	Description
:View<x>:Scale:RisingEdge	Expand the rising edge of waveform on the screen
:View<x>:Scale:XScale (?)	Scale the horizontal axis
:View<x>:Scale:XStart (?)	Set the start point of the horizontal axis on the screen
:View<x>:Scale:YScale (?)	Scale the vertical axis
:View<x>:Scale:YStart (?)	Set the start point of the vertical axis on the screen
:View<x>:Source (?)	Select the input data source
:View<x>:Trace2:TraceVisible (?)	Determine whether or not to display Trace 2
:View<x>:TraceVisible (?)	Determine whether or not to display Trace 1
:View<x>:Version?	Query the version of the CDMA Time View program

### CodeSpectrogram View Commands

*3066 option 15 and 3086 option 16 only.* These commands control the code-domain spectrogram view according to the cdmaOne standard.

**Table 2–21: CodeSpectrogram View commands (3066 option 15 and 3086 option 16 only)**

Header	Description
:View<x>:Marker:DeltaMarker (?)	Turn the delta marker on or off
:View<x>:Marker:ResetDelta	Move the delta marker to the marker position
:View<x>:Marker:SearchMax	Search the maximum peak and place the marker on it
:View<x>:Marker:SearchMin	Search the minimum peak and place the marker on it
:View<x>:Marker:SearchSeparation (?)	Set the resolution to separate two peaks
:View<x>:Marker:X (?)	Set the horizontal position of the marker
:View<x>:Marker:Z (?)	Set the marker position on the Z axis
:View<x>:Monochrome (?)	Set the display to monochrome
:View<x>:NumberColors (?)	Select the number of display colors
:View<x>:Scale:AutoScale	Scale the vertical axis automatically
:View<x>:Scale:XScale (?)	Scale the horizontal axis
:View<x>:Scale:XStart (?)	Set the start point of the horizontal axis on the screen
:View<x>:Scale:YScale (?)	Scale the vertical axis
:View<x>:Scale:YStart (?)	Set the start point of the vertical axis on the screen
:View<x>:Scale:ZScale (?)	Scale the Z axis
:View<x>:Scale:ZStart (?)	Set the start point of the Z axis on the screen

**Table 2-21: CodeSpectrogram View commands  
(3066 option 15 and 3086 option 16 only) (Cont.)**

Header	Description
:View<x>:Version?	Query the version of the CodeSpectrogram View program
:View<x>:ZGap (?)	Set the symbol display interval on the Z axis

**CodePolar View  
Commands**

*3066 option 15 and 3086 option 16 only.* These commands control the vector diagram view according to the cdmaOne standard.

**Table 2-22: CodePolar View commands  
(3066 option 15 and 3086 option 16 only)**

Header	Description
:View<x>:AlphaBT (?)	Set the $\alpha/BT$
:View<x>:Analysis:TimeSlot (?)	Select the symbol to display the constellation
:View<x>:Analyze	Perform analysis on the background for all symbols
:View<x>:AutoCarrier (?)	Turn on or off the carrier search function
:View<x>:BreakAnalyze	Stop analysis
:View<x>:Carrier (?)	Set the carrier frequency
:View<x>:Display (?)	Select the display data source
:View<x>:Format (?)	Select the waveform display format
:View<x>:Marker:T (?)	Set the marker position on the time axis
:View<x>:MeasFilter (?)	Select the filter to create measurement data
:View<x>:Modulation (?)	Select the modulation type
:View<x>:RefFilter (?)	Select the filter to create reference data
:View<x>:Source (?)	Select the input data source
:View<x>:Standard:IS95	Configure the modulating system according to the IS-95 standard without the equalizer
:View<x>:Standard:IS95EQ	Configure the modulating system according to the IS-95 standard with the equalizer
:View<x>:SymbolRate (?)	Set the chip rate
:View<x>:Version?	Query the version of the CodePolar View program

**CodePower View  
Commands**

*3066 option 15 and 3086 option 16 only.* These commands control the code-domain power view according to the cdmaOne standard.

**Table 2-23: CodePower View commands (3066 option 15 and 3086 option 16 only)**

Header	Description
:View<x>:Average (?)	Determine whether to display average results
:View<x>:Average:AllFrames	Specify the average range of all frames
:View<x>:Average:BeginZ (?)	Set the uppermost frame in the average range
:View<x>:Average:EndZ (?)	Set the lowermost frame in the average range
:View<x>:Average:Execute	Execute averaging
:View<x>:Average:MarkerToFrame	Specify the average range between two markers
:View<x>:Average:Times (?)	Set the number of acquisitions for averaging
:View<x>:Average:Type (?)	Select the average type
:View<x>:Marker:DeltaMarker (?)	Turn on or off the delta marker
:View<x>:Marker:ResetDelta	Move the delta marker to the marker position
:View<x>:Marker:SearchMax	Search the maximum peak and place the marker on it
:View<x>:Marker:SearchMin	Search the minimum peak and place the marker on it
:View<x>:Marker:SearchSeparation (?)	Set the resolution to separate two peaks
:View<x>:Marker:X (?)	Set the horizontal position of the marker
:View<x>:Scale:AutoScale	Reset the vertical axis scale to the default
:View<x>:Scale:XScale (?)	Scale the horizontal axis
:View<x>:Scale:XStart (?)	Set the start point of the horizontal axis on the screen
:View<x>:Scale:YScale (?)	Scale the vertical axis
:View<x>:Scale:YStart (?)	Set the start point of the vertical axis on the screen
:View<x>:Version?	Query the version of the CodePower View program
:View<x>:Z (?)	Set the symbol number

**CodeWSpectrogram View Commands**

*3086 option 16 only.* These commands control the code-domain spectrogram view according to the W-CDMA standard.

**Table 2-24: CodeWSpectrogram View commands (3086 option 16 only)**

Header	Description
:View<x>:Marker:DeltaMarker (?)	Turn the delta marker on or off
:View<x>:Marker:ResetDelta	Move the delta marker to the marker position
:View<x>:Marker:SearchMax	Search the maximum peak and place the marker on it
:View<x>:Marker:SearchMin	Search the minimum peak and place the marker on it
:View<x>:Marker:SearchSeparation (?)	Set the resolution to separate two peaks

**Table 2–24: CodeWSpectrogram View commands (3086 option 16 only) (Cont.)**

Header	Description
:View<x>:Marker:X (?)	Set the horizontal position of the marker
:View<x>:Marker:Z (?)	Set the marker position on the Z axis
:View<x>:Monochrome (?)	Set the display to monochrome
:View<x>:NumberColors (?)	Select the number of display colors
:View<x>:Scale:AutoScale	Scale the vertical axis automatically
:View<x>:Scale:XScale (?)	Scale the horizontal axis
:View<x>:Scale:XStart (?)	Set the start point of the horizontal axis on the screen
:View<x>:Scale:YScale (?)	Scale the vertical axis
:View<x>:Scale:YStart (?)	Set the start point of the vertical axis on the screen
:View<x>:Scale:ZScale (?)	Scale the Z axis
:View<x>:Scale:ZStart (?)	Set the start point of the Z axis on the screen
:View<x>:SymbolRate (?)	Set the symbol rate
:View<x>:Version?	Query the version of the CodeWSpectrogram View program
:View<x>:ZGap (?)	Set the symbol display interval on the Z axis

### CodeWPolar View Commands

*3086 option 16 only.* These commands control the vector diagram view according to the W-CDMA standard.

**Table 2–25: CodeWPolar View commands (3086 option 16 only)**

Header	Description
:View<x>:AlphaBT (?)	Set the $\alpha$ /BT
:View<x>:Analysis:TimeSlot (?)	Specify the symbol to display the constellation
:View<x>:Analyze	Perform analysis on the background for all symbols
:View<x>:AutoCarrier (?)	Turn on or off the carrier search function
:View<x>:BreakAnalyze	Stop analysis
:View<x>:Carrier (?)	Set the carrier frequency
:View<x>:Display (?)	Select the display data source
:View<x>:Format (?)	Select the waveform display format
:View<x>:Marker:T (?)	Set the marker position on the time axis
:View<x>:MeasFilter (?)	Select the filter to create measurement data
:View<x>:Modulation (?)	Select the modulation type
:View<x>:RefFilter (?)	Select the filter to create reference data



**Table 2–25: CodeWPolar View commands (3086 option 16 only) (Cont.)**

Header	Description
:View<x>:ShortCode (?)	Specify the short code
:View<x>:Source (?)	Select the input data source
:View<x>:Standard:WCDMA16M	Configure the modulating system according to the W-CDMA standard with the chip rate of 16 M/s
:View<x>:Standard:WCDMA4M	Configure the modulating system according to the W-CDMA standard with the chip rate of 4 M/s
:View<x>:Standard:WCDMA8M	Configure the modulating system according to the W-CDMA standard with the chip rate of 8 M/s
:View<x>:SymbolConstellation (?)	Determine whether to display symbol constellation
:View<x>:SymbolRate (?)	Set the symbol rate
:View<x>:TimeSlot (?)	Specify the time slot
:View<x>:Version?	Query the version of the CodeWPolar View program

### CodeWPower View Commands

*3086 option 16 only.* These commands control the code-domain power view according to the W-CDMA standard.

**Table 2–26: CodeWPower View commands (3086 option 16 only)**

Header	Description
:View<x>:Average (?)	Determine whether to display average results
:View<x>:Average:AllFrames	Specify the average range of all frames
:View<x>:Average:BeginZ (?)	Set the uppermost frame in the average range
:View<x>:Average:EndZ (?)	Set the lowermost frame in the average range
:View<x>:Average:Execute	Execute averaging
:View<x>:Average:MarkerToFrame	Specify the average range between two markers
:View<x>:Average:Times (?)	Set the number of acquisitions for averaging
:View<x>:Average:Type (?)	Select the average type
:View<x>:Marker:DeltaMarker (?)	Turn on or off the delta marker
:View<x>:Marker:ResetDelta	Move the delta marker to the marker position
:View<x>:Marker:SearchMax	Search the maximum peak and place the marker on it
:View<x>:Marker:SearchMin	Search the minimum peak and place the marker on it
:View<x>:Marker:SearchSeparation (?)	Set the resolution to separate two peaks
:View<x>:Marker:X (?)	Set the horizontal position of the marker
:View<x>:Scale:AutoScale	Reset the vertical scale to the default

**Table 2-26: CodeWPower View commands (3086 option 16 only) (Cont.)**

Header	Description
:View<x>:Scale:XScale (?)	Scale the horizontal axis
:View<x>:Scale:XStart (?)	Set the start point of the horizontal axis on the screen
:View<x>:Scale:YScale (?)	Scale the vertical axis
:View<x>:Scale:YStart (?)	Set the start point of the vertical axis on the screen
:View<x>:ShortCode (?)	Specify the short code
:View<x>:SymbolRate (?)	Set the symbol rate
:View<x>:Version?	Query the version of the CodeWPower View program
:View<x>:XAxis (?)	Select the variable for the horizontal axis
:View<x>:Z (?)	Set the time slot number

**CCDF Commands**

*Option 20 only.* These commands control the CCDF (Cumulative Complementary Distribution Function) analysis.

**Table 2-27: CCDF commands (option 20 only)**

Header	Description
:View<x>:AllFrames	Specify the CCDF calculation range of all frames
:View<x>:Average:Reset	Restart the CCDF measurement
:View<x>:BeginZ (?)	Set the uppermost frame in the calculation range
:View<x>:Destination	Select the destination to output the calculation results
:View<x>:EndZ (?)	Set the lowermost frame in the calculation range
:View<x>:Execute	Execute CCDF calculation
:View<x>:Marker:DeltaMarker (?)	Turn on or off the delta marker
:View<x>:Marker:ResetDelta	Move the delta marker to the marker position
:View<x>:Marker:SearchMax	Search the maximum peak and place the marker on it
:View<x>:Marker:SearchMin	Search the minimum peak and place the marker on it
:View<x>:Marker:SearchSeparation (?)	Set the resolution to separate two peaks
:View<x>:Marker:X (?)	Set the horizontal position of the marker
:View<x>:MarkerToFrame	Specify the calculation range between two markers
:View<x>:OutputFormat (?)	Select the format for displaying calculation results
:View<x>:Position (?)	Set the display position in a block
:View<x>:Resolution (?)	Set the resolution of the histogram
:View<x>:Result1?	Query the crest factor

**Table 2-27: CCDF commands (option 20 only) (Cont.)**

Header	Description
:View<x>:Result2?	Query the maximum amplitude
:View<x>:Result3?	Query the average amplitude
:View<x>:Scale:AutoScale	Reset the vertical axis to full-scale
:View<x>:Scale:HoldYScale (?)	Determine whether to hold or reset the vertical scale when you change the input source
:View<x>:Scale:Origin	Reset the vertical and horizontal axis to the default
:View<x>:Scale:XScale (?)	Scale the horizontal axis
:View<x>:Scale:XStart (?)	Set the start point of the horizontal axis on the screen
:View<x>:Scale:XStartZero (?)	Determine whether to set the left edge of each frame to zero on the time axis
:View<x>:Scale:YScale (?)	Scale the vertical axis
:View<x>:Scale:YStart (?)	Set the start point of the vertical axis on the screen
:View<x>:Source (?)	Select the input data source
:View<x>:Version?	Query the version of the CCDF program
:View<x>:Z (?)	Set the frame number

**CCDFView Commands**

*Option 20 only.* These commands control the view of CCDF (Cumulative Complementary Distribution Function) measurement results.

**Table 2-28: CCDFView commands (option 20 only)**

Header	Description
:View<x>:CopyFrom	Copy display data from a data register or text file
:View<x>:CopyTo	Copy display data to a data register or text file
:View<x>:Marker:DeltaMarker (?)	Turns on or off the delta marker
:View<x>:Marker:ResetDelta	Move the delta marker to the marker position
:View<x>:Marker:SearchMax	Search the maximum peak and place the marker on it
:View<x>:Marker:SearchMin	Search the minimum peak and place the marker on it
:View<x>:Marker:SearchSeparation (?)	Set the resolution to separate two peaks
:View<x>:Marker:X (?)	Set the horizontal position of the marker
:View<x>:Scale:AutoScale	Scale the vertical axis automatically
:View<x>:Scale:LYStart (?)	Set the bottom edge of the vertical axis on the screen
:View<x>:Scale:LYStop (?)	Set the top edge of the vertical axis on the screen

**Table 2-28: CCDFView commands (option 20 only) (Cont.)**

Header	Description
:View<x>:Scale:Origin (?)	Reset the vertical and horizontal axis scale to the default
:View<x>:Scale:XScale (?)	Scale the horizontal axis
:View<x>:Scale:XStart (?)	Set the start point of the horizontal axis on the screen
:View<x>:Source (?)	Select the input data source
:View<x>:Version?	Query the version of the CCDFView program

## Utility Commands

These commands are equivalent to the **UTILITY** menu on the front panel.

### Self Gain-Calibration Commands

These commands control the self gain-calibration.

**Table 2-29: Self Gain-Calibration commands**

Header	Description
:Util1:Execute	Perform the self gain-calibration
:Util1:Gain:Auto (?)	Determine whether to perform the self gain-calibration automatically
:Util1:Gain:Execute	Perform the self gain-calibration
:Util1:IQOffset:Execute (the 3086 only)	Compensate the offset of the I and Q input signals
:Util1:Result<x>?	Query the calibration results
:Util1:Version?	Query the version of the Self Gain-Calibration program
:Util1:WideOffset:Request (the 3086 only)	Compensate the offset of the Wideband mode at the next data acquisition

### Save/Load Commands

These commands control to save or load data.

**Table 2-30: Save/Load commands**

Header	Description
:Util2:AllFrames	Specify that the all frames are saved
:Util2:BeginZ (?)	Select the first frame to be saved
:Util2:Buffer:<item> (?)	Set the file header in the buffer

**Table 2–30: Save/Load commands (Cont.)**

Header	Description
:Util2:Buffer:CopyHeader (?)	Store file header to the buffer
:Util2:Buffer:SaveHeader (?)	Save the file header in the buffer to the file
:Util2:Data:Load	Load data from a file in the IQ format
:Util2:Data:Save	Save the data to the file in the IQ or AP format
:Util2:Data:SaveDateTime	Add date and time for the specified frame to the file
:Util2:Data:SaveFlatness	Add calibration data to the file
:Util2:Data:SaveFrame	Add frame data to the file
:Util2:Data:SaveHeader	Save file header for the specified frames to the file
:Util2:Data:Saved	Inform other system programs of the name of the updated file
:Util2:EndZ (?)	Specify the last frame to be saved
:Util2:MarkerToFrame	Specify that the frames between the main marker and the delta marker are saved
:Util2:Source (?)	Select the data source to be saved
:Util2:Version?	Query the version of the Save/Load program

**Average Commands**

These commands control averaging.

**Table 2–31: Average commands**

Header	Description
:Util3:AllFrames	Specify that all frames are processed
:Util3:BeginZ (?)	Specify the first frame to be processed
:Util3:Destination (?)	Specify the destination to which the result of the process is output
:Util3:EndZ (?)	Specify the last frame to be processed
:Util3:MarkerToFrame	Specify that the frames between the main marker and the delta marker are processed
:Util3:PeakHold	Perform average in the peak hold mode
:Util3:RMS	Perform average in the RMS mode
:Util3:Source (?)	Select the input data source
:Util3:Version?	Query the version of the Average program

**Remote Commands** These commands control remote operation.

**Table 2–32: Remote commands**

Header	Description
:Clipboard?	Query the contents of the clipboard
:Set?	Query the instrument settings
[:Util8]:Dev<address>:<command>	Send the command to the GPIB device
[:Util8]:Event:<message>	Generate an event
[:Util8]:Format (?)	Select the waveform display format
[:Util8]:GPIB:Interface (?)	Select the GPIB configuration
[:Util8]:GPIB:PrimaryAddress (?)	Set the GPIB primary address
[:Util8]:Header (?)	Determine whether to include headers on responses
[:Util8]:Id?	Query identifying information about the analyzer
[:Util8]:Key	Equivalent to pressing the button on the front panel
[:Util8]:NewLine (?)	Select the new-line character of query responses
[:Util8]:NumericOutput (?)	Select the numerical format of the returned value
[:Util8]:Register:Data	Write a value to the data register
[:Util8]:Register:Header	Specify axes scaling and labeling for the data register
[:Util8]:Source (?)	Select the input data source
[:Util8]:Source:<item>?	Query the setting for the item
[:Util8]:Status?	Query the status of the analyzer
[:Util8]:TCPIP:Port:Command (?)	Set the TCP/IP command port number
[:Util8]:TCPIP:Port:Command:Reset	Close the TCP/IP command port
[:Util8]:TCPIP:Port:Event (?)	Set the TCP/IP event port number
[:Util8]:TCPIP:Port:Event:Reset	Close the TCP/IP event port
[:Util8]:Version?	Query the version of the Remote program
[:Util8]:ViewName?	Query the name of the Remote program
[:Util8]:Z (?)	Set the frame number
[:Util8]:Z:<item>?	Query information about the frame of input data

# Configuration Commands

Use the Configuration commands to set the analyzer with the basic configuration pattern before acquiring, displaying, and measuring spectra.

## **:Config:Block (No Query Form)**

Starts data acquisition in the Block mode. During data acquisition, this command stops it.

**Syntax** :Config:Block

**Arguments** None

**Examples** :Config:Block  
starts data acquisition in the Block mode. During data acquisition, this command stops it.

**Related Commands** :Config:Start, :Config:Stop

## **:Config:Continue (No Query Form)**

Breaks the pause and starts data acquisition again.

**Syntax** :Config:Continue

**Arguments** None

**Examples** :Config:Continue  
breaks the pause and starts data acquisition again.

**Related Commands** :Config:Pause



## **:Config:Label (No Query Form)**

Displays label in black on the upper left of screen.

**Syntax** :Config:Label <string>

**Arguments** <string>  
Labels must be alphanumeric characters within 32 characters.

**Examples** :Config:Label "Sample Waveform 1"  
displays "Sample Waveform 1" on the upper left of screen.

**Related Commands** :Config:Message

## **:Config:Message (No Query Form)**

Displays message in red on the upper left of screen.

**Syntax** :Config:Message <string>

**Arguments** <string>  
Messages must be alphanumeric characters within 32 characters.

**Examples** :Config:Message "Measure the spectrum"  
displays "Measure the spectrum" in red on the upper left of screen.

**Related Commands** :Config:Label

## :Config:Mode (No Query Form)

Loads the configuration parameters from the analyzer standard configuration file. For details on the parameter settings, refer to the factory initialization settings of the :Config:Mode command on page B-16.

**Syntax**     :Config:Mode { Dual | Freq1 | Freq2 | Zoom | opCDMA1 |  
opCDMA2 | opCDMA3 | opCDMA4 | opCDMA5 | opCDMA6 | opDemod1 |  
opCode1 | opCodeW1 | opCCDF }

**Arguments**

Dual loads the configuration parameters for the Dual mode.

Freq1 loads the configuration parameters to observe spectrum.

Freq2 loads the configuration parameters to observe spectrum and spectrogram.

Zoom loads the configuration parameters for the Zoom mode.

opCDMA1 loads the configuration parameters to measure, analyze, and display the EVM (Error Vector Magnitude),  $\rho$  (Rho meter), frequency error, and origin offset error for the IS-95 standard.

opCDMA2 loads the configuration parameters to measure, analyze, and display the power, occupied bandwidth (OBW), and spurious for the IS-95 standard.

opCDMA3 loads the configuration parameters to measure, analyze, and display the time characteristic for the burst signal for the IS-95 standard.

opCDMA4 loads the configuration parameters to measure, analyze, and display the EVM (Error Vector Magnitude),  $\rho$  (Rho meter), frequency error, and origin offset error for the T-53 standard.

opCDMA5 loads the configuration parameters to measure, analyze, and display the power, occupied bandwidth (OBW), and spurious for the T-53 standard.

opCDMA6 loads the configuration parameters to measure, analyze, and display the time characteristic for the burst signal for the T-53 standard.

opDemod1 loads the configuration parameters to observe digital modulating signals.

opCode1 loads the configuration parameters for the cdmaOne forward link signal analysis (3066 option 15 and 3086 option 16 only).

opCodeW1 loads the configuration parameters for the W-CDMA down-link signal analysis (3086 option 16 only).

opCCDF loads the configuration parameters for the CCDF analysis (option 20 only).

**Examples**     :Config:Mode Dual  
                  loads the configuration file for the Dual mode.

## **:Config:Mode:Load (No Query Form)**

Loads the configuration parameters from the file to which you have stored them previously.

**Syntax**       :Config:Mode:Load <file\_name>

**Arguments**   <file\_name>::=<string> specifies the configuration file (“\*.CFG”).

**Examples**     :Config:Mode:Load "SAMPLE1.CFG"  
                  loads the configuration parameters from the file SAMPLE1.CFG.

**Related Commands**   :Config:Mode:Save

## **:Config:Mode:Save (No Query Form)**

Saves the configuration parameters to a file.

**Syntax**       :Config:Mode:Save <file\_name>

**Arguments**   <file\_name>::=<string> specifies the configuration file (“\*.CFG”).

**Examples**     :Config:Mode:Save "SAMPLE1.CFG"  
                  saves the parameters to the configuration file SAMPLE1.CFG.

**Related Commands**   :Config:Mode:Load

## **:Config:Next (No Query Form)**

Stops to acquire the current block and starts to acquire the next block.

**Syntax**     :Config:Next

**Arguments**   None

**Examples**     :Config:Next  
 stops to acquire the current block and starts to acquire the next block.

## **:Config:Pause (?)**

Turns the Pause mode on or off. In the Pause mode, the data acquisition pauses every block to allow you to process the data. Use the :Config:Continue command to resume.

**Syntax**     :Config:Pause { On | Off }  
               :Config:Pause?

**Arguments**   On turns the Pause mode on.  
               Off turns the Pause mode off.

**Examples**     :Config:Pause On  
 turns the Pause mode on.

**Related Commands**   :Config:Continue

## **:Config:PrintScreen (No Query Form)**

Prints the screen image to the printer specified with the :Config:PrintScreen:Printer command.

**Syntax** :Config:PrintScreen

**Arguments** None

**Examples** :Config:PrintScreen  
prints the screen image to the printer.

**Related Commands** :Config:PrintScreen:Printer

## **:Config:PrintScreen:Printer (?)**

Specifies or queries the printer to print the screen image.

**Syntax** :Config:PrintScreen:Printer <printer\_name>  
:Config:PrintScreen:Printer?

**Arguments** <printer\_name>::=<string> specifies the printer.

**Examples** :Config:PrintScreen:Printer "PRINTER1"  
specifies that the screen image is output to the printer named PRINTER1.

**Related Commands** :Config:PrintScreen

## **:Config:PrintScreen:Printer:Items? (Query Only)**

Returns the list of available printers.

**Syntax** :Config:PrintScreen:Printer:Items?

**Returns** <printer\_name>[,<printer\_name>...]  
 where <printer\_name>::=<string>.

**Examples** :Config:PrintScreen:Printer:Items?  
 might return "PRINTER1", "PRINTER2", "PRINTER3".

**Related Commands** :Config:PrintScreen:Printer

## **:Config:PrintScreen:Save (No Query)**

Save the screen image to a file.

**Syntax** :Config:PrintScreen:Save <file\_name>

**Arguments** <file\_name>::=<string> must be "\*.BMP" (bitmap file).

**Examples** :Config:PrintScreen:Save "C:\SAMPLE1.BMP"  
 save the screen image to the file C:\SAMPLE1.BMP.

**Related Commands** :Config:PrintScreen

## **:Config:Roll (No Query Form)**

Starts data acquisition in the Roll mode. During data acquisition, this command stops it.

**Syntax** :Config:Roll

**Arguments** None

**Examples** :Config:Roll  
starts the data acquisition in the Roll mode. During data acquisition, this command stops it.

**Related Commands** :Config:Block

## **:Config:Setup (?)**

Loads the Setup program for the SETUP menu.

**Syntax** :Config:Setup { None | Standard | CDMA }  
:Config:Setup?

**Arguments** None disables the SETUP menu.  
Standard loads the Standard Setup program.  
CDMA loads the CDMA Setup program.

**Examples** :Config:Setup Standard  
loads the Standard Setup program for the SETUP menu.

## **:Config:Setup:Items? (Query Only)**

Returns the list of available programs for the Setup. Select the program with the :Config:Setup command.

**Syntax** :Config:Setup:Items?

**Returns** <program\_name>[,<program\_name>...]  
 where <program\_name>::=<string>.

**Examples** :Config:Setup:Items?  
 might return None,Standard,CDMA.

**Related Commands** :Config:Setup

## **:Config:Setup:Show (No Query Form)**

Displays the SETUP menu on the analyzer screen.

**Syntax** :Config:Setup:Show

**Arguments** None

**Examples** :Config:Setup:Show  
 displays the Setup menu on the analyzer screen.

**Related Commands** :Config:Setup



## **:Config:Start (No Query Form)**

Starts data acquisition in the Block mode. During data acquisition, the analyzer ignores this command.

**Syntax**     :Config:Start

**Arguments**   None

**Examples**     :Config:Start  
starts data acquisition in the Block mode.

**Related Commands**   :Config:Stop

## **:Config:StartAgain (No Query Form)**

Stops the data acquisition and restarts data acquisition in the Block mode.

**Syntax**     :Config:StartAgain

**Arguments**   None

**Examples**     :Config:StartAgain  
stops the data acquisition and restarts data acquisition in the Block mode.

**Related Commands**   :Config:Start, :Config:Stop

## **:Config:Status:Overload? (Query Only)**

Queries whether the analyzer's A/D converter overloads.

**Syntax**     :Config:Status:Overload?

**Returns**    On indicates the analyzer's A/D converter overloads.

Off indicates the analyzer's A/D converter does not overload.

**Examples**    :Config:Status:Overload?  
might return On that indicates the analyzer's A/D converter overloads.

## **:Config:Status:Pause? (Query Only)**

Queries whether data acquisition pauses.

**Syntax**     :Config:Status:Pause?

**Returns**    On indicates data acquisition stops.

Off indicates the analyzer is acquiring data.

**Examples**    :Config:Status:Pause?  
might return On that indicates data acquisition stops.

## :Config:Status:Triggered? (Query Only)

Queries whether the analyzer is triggered.

**Syntax** :Config:Status:Triggered?

**Returns** On indicates the analyzer is triggered.  
Off indicates the analyzer is not triggered.

**Examples** :Config:Status:Triggered?  
might return On that indicates the analyzer is triggered.

## :Config:Status:Uncal? (Query Only)

Queries whether the analyzer is in an uncalibrated state due to the increased temperature.

---

**NOTE.** *If the instrument is in the uncal state, perform the self gain-calibration to ensure the normal operation.*

---

**Syntax** :Config:Status:Uncal?

**Returns** On indicates the analyzer is not calibrated.  
Off indicates the analyzer is calibrated.

**Examples** :Config:Status:Uncal?  
might return On which indicates the analyzer is not calibrated.

**Related Commands** :Util1:Execute

## **:Config:Stop (No Query Form)**

Stops data acquisition. When data acquisition stops, the analyzer ignores this command.

**Syntax** :Config:Stop

**Arguments** None

**Examples** :Config:Stop  
stops the data acquisition.

**Related Commands** :Config:Start, :Config:StartAgain

## **:Config:System? (Query Only)**

Queries the instrument name.

**Syntax** :Config:System?

**Returns** <NR1>

**Examples** :Config:System?  
might return 3086.

## :Config:Util:Items? (Query Only)

Returns the list of available programs for the Utility 1 to 8 (A to H). Select the program with the :Config:Util<x> command.

**Syntax** :Config:Util:Items?

**Returns** <program\_name>[,<program\_name>...]  
where <program\_name>::=<string>.

**Examples** :Config:Util:Items?  
might return None,SelfGainCal,SaveLoad,Average.

**Related Commands** :Config:Util<x>

## :Config:Util<x> (?)

Assigns the utility program to the **UTILITY** side key.

---

**NOTE.** *UTILITY 1, 2, 3, and 8 are already used; Self Gain-Calibration, Save/Load, Average, and Remote, respectively. You can assign UTILITY 4 to 7 when new utility programs are released.*

---

**Syntax** :Config:Util<x> { <name> | None }  
:Config:Util<x>?

**Arguments** <name>::=<string> is the utility program name.  
None disables the **UTILITY** side key.

**Examples** :Config:Util5 SAMPLE  
assigns the utility program SAMPLE to the **UTILITY 5** (UTILITY E) key.  
:Config:Util1 None  
disables the **UTILITY 1** (UTILITY A) key.

## **:Config:Util<x>:Show (No Query Form)**

Displays the utility menu for the specified **UTILITY** side key.

**Syntax** :Config:Util<x>:Show

**Arguments** None

**Examples** :Config:Util1:Show  
displays the utility menu of the **UTILITY 1** side key.

**Related Commands** :Config:Util<x>

## **:Config:Version? (Query Only)**

Queries the version of the Configuration program.

**Syntax** :Config:Version?

**Returns** <NR2>

**Examples** :Config:Version?  
might return 1.1.

## **:Config:View:BackgroundColor (?)**

Selects or queries the background color of the waveform display area.

**Syntax**    :Config:View:BackgroundColor { Black | White }  
              :Config:View:BackgroundColor?

**Arguments**    Black selects black for the background color.  
                  White selects white for the background color.

**Examples**     :Config:View:BackgroundColor Black  
                  selects black for the background color.

## **:Config:View:Items? (Query Only)**

Returns the list of available programs for the View 1 to 8 (A to H). Select the program with the :Config:View<x> command.

**Syntax**        :Config:View:Items?

**Returns**        <program\_name>[,<program\_name>...]  
                  where <program\_name>::=<string>.

**Examples**        :Config:View:Items?  
                  might return None,Waveform,Spectrogram,Waterfall.

**Related Commands**    :Config:View<x>, :Config:View<x>:Show

## **:Config:View:MarkerLink (?)**

Determines whether the markers in different views move together in unison or separately.

**Syntax**     :Config:View:MarkerLink { On | Off }  
                   :Config:View:MarkerLink?

**Arguments**   On ties the markers in different views together.  
                   Off frees the markers in different views to move separately.

**Examples**     :Config:View:MarkerLink On  
                   specifies that the markers in different views move in unison.

## **:Config:View:Style (?)**

Specifies or queries the layout of the views on screen.

**Syntax**     :Config:View:Style { OneByOne | OneByTwo | OneByFour | TwoByTwo }  
                   :Config:View:Style?

**Arguments**   OneByOne specifies that one view displays on the screen.  
                   OneByTwo selects 1 × 2 view display.  
                   OneByFour selects 1 × 4 view display.  
                   TwoByTwo selects 2 × 2 view display.

**Examples**     :Config:View:Style TwoByTwo  
                   selects 2 × 2 view display.

## **:Config:View<x> (?)**

Assigns the View program to the **VIEW** key.



**Syntax** :Config:View<x> { None | Waveform | Analog | FSK | Spectrogram | Waterfall | Polar | EyeDiagram | SymbolTable | EVM | CDMAWaveform | CDMA Polar | CDMA Time | CodeSpectrogram | CodePolar | CodePower | CodeWSpectrogram | CodeWPolar | CodeWPower | CCDF | CCDFView }  
:Config:View<x>?

**Arguments** Each argument represents the system program for the specific measurement. For detail settings, refer to the section starting on the page listed below.

Argument	System program	Display form	Detail settings
None	None	None	-
Waveform	Waveform View	Spectrum	p. 2-91
Analog	Analog View	Time domain for AM/FM/PM	p. 2-119
FSK	FSK View	Time domain for FSK	p. 2-131
Spectrogram	Spectrogram View	Spectrogram	p. 2-141
Waterfall	Waterfall View	Waterfall	p. 2-155
Polar	Polar View	Polar	p. 2-171
EyeDiagram	Eye Diagram View	Eye Diagram	p. 2-187
SymbolTable	Symbol Table View	Symbol Table	p. 2-191
EVM	EVM View	Error vector magnitude	p. 2-197
CDMAWaveform	CDMA Waveform View	Spectrum for IS-95/T-53	p. 2-207
CDMAPolar	CDMA Polar View	Polar for IS-95/T-53	p. 2-229
CDMA Time	CDMA Tlme View	Time domain for IS-95/T-53	p. 2-247
CodeSpectrogram <sup>1</sup>	CodeSpectrogram View	Spectrogram (cdmaOne)	p. 2-267
CodePolar <sup>1</sup>	CodePolar View	Polar (cdmaOne)	p. 2-277
CodePower <sup>1</sup>	CodePower View	Spectrum (cdmaOne)	p. 2-287
CodeWSpectrogram <sup>2</sup>	CodeWSpectrogram View	Spectrogram (cdmaOne)	p. 2-299
CodeWPolar <sup>2</sup>	CodeWPolar View	Polar (cdmaOne)	p. 2-309
CodeWPower <sup>2</sup>	CodeWPower View	Spectrum (cdmaOne)	p. 2-319
CCDF <sup>3</sup>	CCDF	Time domain for CCDF	p. 2-331
CCDFView <sup>3</sup>	CCDFView	CCDF	p. 2-347

<sup>1</sup> 3066 option 15 and 3086 option 16 only.

<sup>2</sup> 3086 option 16 only.

<sup>3</sup> Option 20 only.

**Examples**     :Config:View1 Waveform  
                  assigns the Waveform View program to the **VIEW 1** (VIEW A) key.

**Related Commands**     :Config:View:Items

## **:Config:View<x>:Show (No Query Form)**

Displays the View menu on the analyzer screen for the specified view.

**Syntax**     :Config:View<x>:Show

**Arguments**     None

**Examples**     :Config:View1:Show  
                  displays the View 1 (View A) menu on the analyzer screen.

**Related Commands**     :Config:View<x>

## Standard Setup Commands

When you select Standard in the Config:Setup command, use the commands in this section to set the details for the standard setup.

**:Setup:BlockSize (?)**

Sets or queries the number of frames per block.

**Syntax**   :Setup:BlockSize <value>  
          :Setup:BlockSize?

**Arguments**   <value>::=<NR1> depends on the FFT points and the memory mode:

FFT points	Memory mode	<value>
256	-	1 to 16000
1024	Frequency	1 to 4000
	Other than Frequency	1 to 2000

**Examples**   :Setup:BlockSize 200  
          sets the number of frames per block to 200.

**Related Commands**   :Setup:FFTPoints, :Setup:MemoryMode

**:Setup:CenterFrequency (?)**

Sets or queries the center frequency.

**Syntax** :Setup:CenterFrequency <value>  
:Setup:CenterFrequency?

**Arguments** <value>: :=<NR3> depends on the input mode:

Input mode	<value>
IQ <sup>1</sup>	0
Wideband <sup>1</sup> , RF	Span/2 Hz to 3 GHz – Span/2 Hz
Baseband	Span/2 Hz to 10 MHz – Span/2 Hz

<sup>1</sup> **The 3086 only.**

**Examples** :Setup:CenterFrequency 1.5G  
sets the center frequency to 1.5 GHz.

**Related Commands** :Setup:InputMode

**:Setup:FFTPoints (?)**

Sets or queries the number of FFT sampling points per frame.

**Syntax**     :Setup:FFTPoints <value>  
              :Setup:FFTPoints?

**Arguments**   <value>::=<NR1> depends on the memory mode:

Memory mode	<value>
Frequency	{ 1024   256 }
Other than Frequency	1024

**Examples**     :Setup:FFTPoints 1024  
                  sets the number of FFT points to 1024.

**Related Commands**   :Setup:MemoryMode

**:Setup:FFTWindow (?)**

Selects or queries the FFT window.

**Syntax**     :Setup:FFTWindow { Blackman | Hamming | Rect }  
              :Setup:FFTWindow?

**Arguments**   Blackman selects the Blackman-Harris window.  
                  Hamming selects the Hamming window.  
                  Rect selects the Rectangular window.

**Examples**     :Setup:FFTWindow Blackman  
                  selects the Blackman-Harris window.

## **:Setup:FramePeriod (?)**

Sets or queries the frame period in the Block mode. The setting is effective in the Frequency and Dual memory mode. In the Zoom mode, this setting is ignored.

**Syntax**     :Setup:FramePeriod <value>  
              :Setup:FramePeriod?

**Arguments**   <value>::=<NR3> ranges 20  $\mu$ s to 60 s.

**Examples**     :Setup:FramePeriod 30m  
                  sets the frame period to 30 ms.

**Related Commands**   :Setup:MemoryMode

## **:Setup:FrequencyOffset (?)**

Sets or queries the frequency display offset. This setting is useful, for example, when a down converter connects externally. It has no effect on the analyzer hardware settings.

**Syntax**     FrequencyOffset <value>  
              FrequencyOffset?

**Arguments**   <value>::=<NR3> ranges –100 GHz to 100 GHz.

**Examples**     :Setup:FrequencyOffset 100G  
                  sets the frequency display offset to 100 GHz.

**Related Commands**   :Setup:CenterFrequency

**:Setup:InputCoupling (?)**

Selects or queries the input coupling to the RF INPUT connector on the front panel. In the IQ mode of the 3086, this command is ignored.

**Syntax**     :Setup:InputCoupling <value>  
              :Setup:InputCoupling?

**Arguments**   <value> depends on the input mode:

Input mode	<value>
Wideband <sup>1</sup> , RF	AC
Baseband	{ AC   GND   DC }

<sup>1</sup>   **The 3086 only.**

AC sets the input coupling to AC.

GND sets the input coupling to ground.

DC sets the input coupling to DC.

**Examples**     :Setup:InputCoupling AC  
                  sets the RF input coupling to AC.

**Related Commands**   :Setup:InputMode



**:Setup:InputMode (?)**

Selects or queries the signal input mode.

**Syntax** :Setup:InputMode { IQ | Wideband | RF | Baseband }  
:Setup:InputMode?

**Arguments** IQ selects the IQ mode (the 3086 only). This mode processes the I and Q input signals from the rear panel connectors.

Wideband selects the Wideband mode (the 3086 only). This mode can process 50 MHz to 3 GHz signals with maximum 30 MHz span in the vector mode.

RF selects the RF mode. This mode can process 10 MHz to 3 GHz signals with maximum 6 MHz span.

Baseband selects the baseband mode. This mode does not use the internal 3 GHz down converter. It can only process DC to 10 MHz signals.

**Examples** :Setup:InputMode RF  
selects the RF mode.

**Related Commands** :Setup:CenterFrequency, :Setup:InputCoupling

**:Setup:LevelOffset (?)**

Sets or queries the level display offset. This setting is useful, for example, when an attenuator connects externally. It has no effect on the analyzer hardware settings.

**Syntax** :Setup:LevelOffset <value>  
:Setup:LevelOffset?

**Arguments** <value>::=<NR3> ranges –100 dB to 100 dB.

**Examples** :Setup:LevelOffset 100  
sets the level display offset to 100 dB.

**Related Commands** :Setup:ReferenceLevel

## **:Setup:Load (No Query Form)**

Loads the trigger mask from the specified file.

**Syntax**     :Setup:Load <file\_name>

**Arguments**   <file\_name>::=<string> specifies the file that contains the trigger mask.  
The file name must be "\*.TRG".

**Examples**     :Setup:Load "SAMPLE1.TRG"  
loads the trigger mask from the file SAMPLE1.TRG.

**Related Commands**   :Setup:Save

## **:Setup:MarkerToFreq (No Query Form)**

Sets the center frequency to the value at the marker.

**Syntax**     :Setup:MarkerToFreq

**Arguments**   None

**Examples**     :Setup:MarkerToFreq  
sets the center frequency to the value at the marker.

**Related Commands**   :Setup:CenterFrequency

## **:Setup:MaxSpan (No Query Form)**

Sets the span to the maximum.

**Syntax** :Setup:MaxSpan

**Arguments** None

**Examples** :Setup:MaxSpan  
sets the span to the maximum.

**Related Commands** :Setup:Span

## **:Setup:MemoryMode (?)**

Selects or queries the memory mode.

**Syntax** :Setup:MemoryMode { Frequency | Dual | Zoom }  
:Setup:MemoryMode?

**Arguments** Frequency selects the Frequency mode. Only frequency domain data is written into the memory.

Dual selects the Dual mode. The data for both frequency and time domain are written into the memory at the same time.

Zoom expands a specific part of the spectrum.

In the IQ mode of the 3086, the memory mode is fixed to the Zoom.

**Examples** :Setup:MemoryMode Frequency  
sets the memory mode to Frequency.

**Related Commands** :Setup:BlockSize, :Setup:FFTPoints, :Setup:FramePeriod

**:Setup:ReferenceLevel (?)**

Sets or queries the reference level.

**Syntax**     :Setup:ReferenceLevel <value>  
              :Setup:ReferenceLevel?

**Arguments**   <value> ::= <NR1> depends on the input mode:

Input mode	<value>
IQ <sup>1</sup>	0
Wideband <sup>1</sup> , RF	-50 dBm to 30 dBm
Baseband	-30 dBm to 30 dBm

<sup>1</sup>   **The 3086 only.**

**Examples**     :Setup:ReferenceLevel 30  
                  sets the reference level to 30 dBm.

**Related Commands**   :Setup:LevelOffset

## **:Setup:ReferenceOsc (?)**

Selects or queries the reference oscillator.

**Syntax**    :Setup:ReferenceOsc { Internal | External }  
              :Setup:ReferenceOsc?

**Arguments**    Internal selects the internal reference oscillator. It generates 10 MHz sine wave.  
  
                  External selects the external reference oscillator. It is connected to the 10 MHz REF INPUT connector on the rear panel.

**Examples**     :Setup:ReferenceOsc Internal  
                  selects the internal reference oscillator.

## **:Setup:Save (No Query Form)**

Saves the trigger mask to the specified file.

**Syntax**     :Setup:Save <file\_name>

**Arguments**    <file\_name>::=<string> specifies the file to save the trigger mask.  
                  The file name must be "\*.TRG".

**Examples**     :Setup:Save "SAMPLE1.TRG"  
                  saves the trigger mask to the file SAMPLE1.TRG.

**Related Commands**    :Setup:Load

**:Setup:Span (?)**

Sets or queries the span.

**Syntax** :Setup:Span <value>  
:Setup:Span?

**Arguments** <value> depends on the input mode and the memory mode:

Input mode	Memory mode	<value>
IQ <sup>1</sup> , Wideband <sup>1</sup>	-	{ 30M   20M   10M }
RF	Other than Zoom	{ 3G   2G   1G   500M   200M   100M   50M   30M   20M   10M   6M   5M   2M   1M   500k   200k   100k   50k   20k   10k   5k   2k   1k   500   200   100 }
	Zoom	{ 3G   2G   1G   500M   200M   100M   50M   30M   20M   10M   5M   2M   1M   500k   200k   100k   50k   20k   10k   5k   2k   1k   500   200   100 }
Baseband	Other than Zoom	{ 10M   6M   5M   2M   1M   500k   200k   100k   50k   20k   10k   5k   2k   1k   500   200   100 }
	Zoom	{ 5M   2M   1M   500k   200k   100k   50k   20k   10k   5k   2k   1k   500   200   100 }

<sup>1</sup> The 3086 only.

**Examples** :Setup:Span 1M  
sets the span to 1 MHz.

**Related Commands** :Setup:InputMode, :Setup:MemoryMode

**:Setup:Trigger (?)**

Selects or queries the trigger mode.

**Syntax** :Setup:Trigger { Auto | Delayed | Interval | Never | Normal | Quick | QuickInterval | Timeout }  
:Setup:Trigger?

- Arguments**
- In the IQ and Wideband modes of the 3086, you can not select Quick and QuickInterval.
  - Auto acquires data regardless of trigger generation as follows:
    - If you have turned off the trigger count, the data acquisition will repeat until you stop it.
    - If you have turned on the trigger count, the data will be acquired the number of times specified with the :Setup:TriggerTimes command after you start the acquisition.
  - Delayed causes the data acquisition to stop for the time after the trigger specified with the :Setup:TriggerDelayed command.
  - Interval specifies that a block data is acquired and displayed at the time interval set with the :Setup:TriggerInterval command.
  - Never ignores any trigger settings. The data acquisition repeats until you stop it.
  - Normal waits for a valid trigger event.
  - Quick is the same as the Normal except that data is displayed after all blocks are acquired. It shortens the time interval between two block data acquisitions. In the Normal mode, the interval is several decade milli-seconds. In the Quick mode, it is several hundred micro-seconds.
  - QuickInterval is the same as the Interval, except that data is displayed after all blocks are acquired. You can capture phenomena which are missed during data display in the Interval mode.
  - Timeout stops the data acquisition if the trigger event does not occur within the time specified with the :Setup:TriggerTimeout command. This argument is effective only when the trigger source is set to Internal.

**Examples**

```
:Setup:Trigger Auto
selects the Auto trigger mode.
```

**Related Commands**

```
:Config:Block, :Config:Start, :Config:Stop,
:Setup:TriggerCount, :Setup:TriggerDelayed, :Setup:TriggerDomain,
:Setup:TriggerInterval, :Setup:TriggerPosition,
:Setup:TriggerSlope, :Setup:TriggerSource, :Setup:TriggerTimeout,
:Setup:TriggerTimes
```

**:Setup:TriggerCount (?)**

Turns the trigger counter on or off.

**Syntax**     :Setup:TriggerCount { On | Off }  
              :Setup:TriggerCount?

**Arguments**   On turns the trigger counter on.  
              Off turns the trigger counter off.

**Examples**     :Setup:TriggerCount On  
                  turns the trigger counter on.

**Related Commands**   :Setup:Trigger, :Setup:TriggerTimes

**:Setup:TriggerDelayed (?)**

Sets or queries the delay time for the Delayed trigger mode.

**Syntax**     :Setup:TriggerDelayed <value>  
              :Setup:TriggerDelayed?

**Arguments**   <value>::=<NR3> specifies the delay time. The range is 0 to 60 s.

**Examples**     :Setup:TriggerDelayed 100m  
                  sets the trigger delay time to 100 ms.

**Related Commands**   :Setup:Trigger



## **:Setup:TriggerDomain (?)**

Sets or queries the domain in which the analyzer is triggered.

**Syntax**     :Setup:TriggerDomain { Frequency | Time }  
              :Setup:TriggerDomain?

**Arguments**   Frequency selects the frequency domain for trigger.  
              Time selects the time domain for trigger.

**Examples**     :Setup:TriggerDomain Frequency  
              selects the frequency domain for trigger.

**Related Commands**   :Setup:Trigger

## **:Setup:TriggerInterval (?)**

Sets or queries the time interval for the Interval and Quick Interval trigger modes.

**Syntax**     :Setup:TriggerInterval <value>  
              :Setup:TriggerInterval?

**Arguments**   <value>::=<NR3> ranges 1 s to 3600 s.

**Examples**     :Setup:TriggerInterval 3000  
              sets the time interval for the Interval and Quick Interval trigger modes to 3000 s.

**Related Commands**   :Setup:Trigger

## **:Setup:TriggerPosition (?)**

Sets or queries the trigger position.

**Syntax**     :Setup:TriggerPosition <value>  
              :Setup:TriggerPosition?

**Arguments**   <value>::=<NR2> ranges 0 to 100 % in 1 % step.  
The trigger position represents the ratio of the number of frames preceding the trigger generation to that of one block.

**Examples**     :Setup:TriggerPosition 10  
For example, if the block size is 1,000 frames, 100 frames will be acquired before the trigger generation, and 900 frames after it.

**Related Commands**   :Setup:Trigger

## **:Setup:TriggerSlope (?)**

Selects or queries a rising or falling edge for the trigger.

**Syntax**     :Setup:TriggerSlope { Rise | Fall }  
              :Setup:TriggerSlope?

**Arguments**   Rise specifies to trigger on the rising or positive edge of a signal.  
Fall specifies to trigger on the falling or negative edge of a signal.

**Examples**     :Setup:TriggerSlope Rise  
specifies to trigger on the rising edge of a signal.

**Related Commands**   :Setup:Trigger, :Setup:TriggerSource

## **:Setup:TriggerSource (?)**

Selects or queries the trigger source.

**Syntax**     :Setup:TriggerSource { Internal | External }  
              :Setup:TriggerSource?

**Arguments**   Internal uses the trigger mask pattern stored in the internal register for trigger generation.  
  
              External uses the signal from the EXT TRIG connector on the front panel as a trigger input.  
  
              In the IQ mode of the 3086, the source is fixed to External.

**Examples**     :Setup:TriggerSource Internal  
              uses the trigger mask pattern stored in the internal register as the trigger source.

**Related Commands**   :Setup:Trigger

## **:Setup:TriggerTimeout (?)**

Sets or queries the timeout value in the Timeout trigger mode.

**Syntax**     :Setup:TriggerTimeout <value>  
              :Setup:TriggerTimeout?

**Arguments**   <value>::=<NR3> specifies the timeout value. The range is 0 to 60 s.

**Examples**     :Setup:TriggerTimeout 30  
              sets the timeout to 30 s.

**Related Commands**   :Setup:Trigger

**:Setup:TriggerTimes (?)**

Sets or queries the trigger count for the Count trigger mode.

**Syntax** :Setup:TriggerTimes <value>

:Setup:TriggerTimes?

**Arguments** <value>::=<NR1> depends on the FFT points and the memory mode:

FFT points	Memory mode	<value>
256	-	1 to 16000/(Block size)
1024	Frequency	1 to 4000/(Block size)
	Other than Frequency	1 to 2000/(Block size)

**Examples** :Setup:TriggerTimes 10  
sets the trigger count to 10.

**Related Commands** :Setup:Trigger

**:Setup:Version? (Query Only)**

Queries the version of the Setup program.

**Syntax** :Setup:Version?

**Returns** <NR2> indicates the version number.

**Examples** :Setup:Version?  
might return 1.1.

## **:Setup:Zoom:Execute (No Query Form)**

Zooms waveform with the expansion factor specified by the :Setup:Zoom:Mag command.

**Syntax** :Setup:Zoom:Execute

**Arguments** None

**Examples** :Setup:Zoom:Execute  
zooms waveform.

**Related Commands** :Setup:MemoryMode, :Setup:Zoom:Frequency, :Setup:Zoom:Mag

## **:Setup:Zoom:Frequency (?)**

Sets or queries the center frequency for the zoom.

**Syntax** :Setup:Zoom:Frequency <value>

:Setup:Zoom:Frequency?

**Arguments** <value>::=<NR3> specifies the center frequency for the zoom.

**Examples** :Setup:Zoom:Frequency 1.5G  
sets the center frequency for the zoom to 1.5 GHz.

**Related Commands** :Setup:Zoom:Execute, :Setup:Zoom:Mag

**:Setup:Zoom:Mag (?)**

Sets or queries the expansion factor in the Zoom mode.

**Syntax**     :Setup:Zoom:Mag <value>  
              :Setup:Zoom:Mag?

**Arguments**   <value>::=<NR1> is the expansion factor. It depends on the span.

Span before zoom	Expansion factor
5 MHz	2   5   10   20   50   100   200   500   1000
Other than 5 MHz	2   4   10   20   40   100   200   400   1000

In the IQ and Wideband modes of the 3086, the expansion factor is the same as in 5 MHz span.

**Examples**     :Setup:Zoom:Mag 10  
                  magnifies the display 10 times.

**Related Commands**   :Setup:Zoom:Execute, :Setup:Zoom:Frequency

# CDMA Setup Commands

When you select CDMA in the `Config:Setup` command, use the commands in this section to set the details for the CDMA setup.

**:Setup:BlockSize (?)**

Sets or queries the number of frames per block.

**Syntax**   :Setup:BlockSize <value>  
          :Setup:BlockSize?

**Arguments**   <value>::=<NR1> depends on the FFT points and the memory mode:

FFT points	Memory mode	<value>
256	-	1 to 16000
1024	Frequency	1 to 4000
	Other than Frequency	1 to 2000

**Examples**   :Setup:BlockSize 200  
              sets the number of frames per block to 200.

**Related Commands**   :Setup:FFTPoints, :Setup:MemoryMode



## **:Setup:CDMA:Channel (?)**

Selects or queries the channel.

**Syntax** :Setup:CDMA:Channel <value>  
:Setup:CDMA:Channel?

**Arguments** <value>: :=<NR1> specifies the channel number.

For the IS-95 standard, the range is 1 to 777. Channel 1 and 777 correspond to 825.03 and 848.31 MHz, respectively. The frequency difference between two adjacent channels is 0.03 MHz.

For the T-53 standard, the range is 1 to 1199. Channel 1 and 1199 correspond to 915.0125 and 888.9875 MHz, respectively. The frequency difference between two adjacent channels is 0.0125 MHz.

**Examples** :Setup:CDMA:Channel 777  
sets the channel number to 777.

**Related Commands** :Setup:CDMA:Standard

## **:Setup:CDMA:Span30M (No Query Form)**

Sets the span to 30 MHz. This command is used for the IS-95 standard.

**Syntax** :Setup:CDMA:Span30M

**Arguments** None

**Examples** :Setup:CDMA:Span30M  
sets the span to 30 MHz.

**Related Commands** :Setup:Span

**:Setup:CDMA:Span50M (No Query Form)**

Sets the span to 50 MHz. This command is used for the T-53 standard.

**Syntax** :Setup:CDMA:Span50M

**Arguments** None

**Examples** :Setup:CDMA:Span50M  
sets the span to 50 MHz.

**Related Commands** :Setup:Span

**:Setup:CDMA:Span5MAuto (No Query Form)**

Sets the span to 5 MHz and the trigger mode to Auto.

**Syntax** :Setup:CDMA:Span5MAuto

**Arguments** None

**Examples** :Setup:CDMA:Span5MAuto  
sets the span to 5 MHz and the trigger mode to Auto.

**Related Commands** :Setup:Span

## **:Setup:CDMA:Span5MNormal (No Query Form)**

Sets the span to 5 MHz and the trigger mode to Normal.

**Syntax** :Setup:CDMA:Span5MNormal

**Arguments** None

**Examples** :Setup:CDMA:Span5MNormal  
sets the span to 5 MHz and the trigger mode to Normal.

**Related Commands** :Setup:Span

## **:Setup:CDMA:Standard (?)**

Selects or queries the CDMA standard.

**Syntax** :Setup:CDMA:Standard { IS95 | T53 }  
:Setup:CDMA:Standard?

**Arguments** IS95 selects the IS-95 standard.  
T53 selects the T-53 standard.

**Examples** :Setup:CDMA:Standard IS95  
selects the IS-95 standard.

**:Setup:CDMA:TriggerLevel (?)**

Sets or queries the trigger level in the time domain.

**Syntax**     :Setup:CDMA:TriggerLevel <value>  
              :Setup:CDMA:TriggerLevel?

**Arguments**   <value>::=<NR2> specifies the trigger level. The range is -40 dB to 0 dB.

**Examples**     :Setup:CDMA:TriggerLevel 0  
                  sets the trigger level to 0 dB.

**:Setup:MarkerToFreq (No Query Form)**

Sets the center frequency to the value at the marker.

**Syntax**     :Setup:MarkerToFreq

**Arguments**   None

**Examples**     :Setup:MarkerToFreq  
                  sets the center frequency to the value at the marker.

**:Setup:MaxSpan (No Query Form)**

Sets the span to the maximum.

**Syntax**     :Setup:MaxSpan

**Arguments**   None

**Examples**     :Setup:MaxSpan  
                  sets the span to the maximum.

**Related Commands**   :Setup:Span

## **:Setup:ReferenceLevel (?)**

Sets or queries the reference level.

**Syntax**     :Setup:ReferenceLevel <value>  
              :Setup:ReferenceLevel?

**Arguments**   <value>: :=<NR1> specifies the reference level.  
                  The range is -50 dBm to 30 dBm.

**Examples**     :Setup:ReferenceLevel 30  
                  sets the reference level to 30 dBm.

## **:Setup:ReferenceOsc (?)**

Selects or queries the reference oscillator.

**Syntax**     :Setup:ReferenceOsc { Internal | External }  
              :Setup:ReferenceOsc?

**Arguments**   Internal selects the internal reference oscillator. It generates 10 MHz sine wave.  
  
                  External selects the external reference oscillator. It is connected to the 10 MHz REF INPUT connector on the rear panel.

**Examples**     :Setup:ReferenceOsc Internal  
                  selects the internal reference oscillator.

## :Setup:Span (?)

Sets or queries the span.

**Syntax** :Setup:Span <value>  
:Setup:Span?

**Arguments** <value> specifies the span. It depends on the input mode and the memory mode:

Input mode	Memory mode	Span
RF	Other than Zoom	{ 3G   2G   1G   500M   200M   100M   50M   30M   20M   10M   6M   5M   2M   1M   500k   200k   100k   50k   20k   10k   5k   2k   1k   500   200   100 }
	Zoom	{ 3G   2G   1G   500M   200M   100M   50M   30M   20M   10M   5M   2M   1M   500k   200k   100k   50k   20k   10k   5k   2k   1k   500   200   100 }
Baseband	Other than Zoom	{ 10M   6M   5M   2M   1M   500k   200k   100k   50k   20k   10k   5k   2k   1k   500   200   100 }
	Zoom	{ 5M   2M   1M   500k   200k   100k   50k   20k   10k   5k   2k   1k   500   200   100 }

**Examples** :Setup:Span 5M  
sets the span to 5 MHz.

**Related Commands** :Setup:CDMA:Span30M, :Setup:CDMA:Span5MAuto,  
:Setup:CDMA:Span5MNormal, :Setup:MaxSpan

## **:Setup:Trigger (?)**

Selects or queries the trigger mode.

**Syntax**     :Setup:Trigger { Auto | Delayed | Interval | Never | Normal | Quick | QuickInterval | Timeout }  
:Setup:Trigger?

**Arguments**   Auto acquires data regardless of trigger generation as follows:  
If you have turned off the trigger count, the data acquisition will repeat until you stop it.  
If you have turned on the trigger count, the data will be acquired the number of times specified with the :Setup:TriggerTimes command after you start the acquisition.

Delayed causes the data acquisition to stop the specified time after the trigger.

Interval specifies that a block data is acquired and displayed at the time interval set with the :Setup:TriggerInterval command.

Never ignores any trigger settings. The data acquisition repeats until you stop it.

Normal waits for a valid trigger event.

Quick is the same as the Normal except that data is displayed after all blocks are acquired. It shortens the time interval between two block data acquisitions. In the Normal mode, the interval is several decade milli-seconds. In the Quick mode, it is several hundred micro-seconds.

QuickInterval is the same as the Interval, except that data is displayed after all blocks are acquired. You can capture phenomena which are missed during data display in the Interval mode.

Timeout stops the data acquisition if the trigger event does not occur within the time specified with the :Setup:TriggerTimeout command. This argument is effective only when the trigger source is set to Internal.

**Examples**     :Setup:Trigger Auto  
selects the Auto trigger mode.

**Related Commands**   :Config:Block, :Config:Start, :Config:Stop,  
:Setup:TriggerCount, :Setup:TriggerDelayed, :Setup:TriggerDomain,  
:Setup:TriggerInterval, :Setup:TriggerPosition,  
:Setup:TriggerSlope, :Setup:TriggerSource, :Setup:TriggerTimeout,  
:Setup:TriggerTimes

**:Setup:TriggerCount (?)**

Turns the trigger counter on or off.

**Syntax**     :Setup:TriggerCount { Off | On }  
              :Setup:TriggerCount?

**Arguments**   On turns the trigger counter on.  
              Off turns the trigger counter off.

**Examples**     :Setup:TriggerCount On  
                  turns the trigger counter on.

**Related Commands**   :Setup:Trigger, :Setup:TriggerTimes

**:Setup:TriggerDelayed (?)**

Sets or queries the delay time for the Delayed trigger mode.

**Syntax**     :Setup:TriggerDelayed <value>  
              :Setup:TriggerDelayed?

**Arguments**   <value>::=<NR3> specifies the delay time. The range is 0 to 60 s.

**Examples**     :Setup:TriggerDelayed 100m  
                  sets the trigger delay time to 100 ms.

**Related Commands**   :Setup:Trigger



## **:Setup:TriggerDomain (?)**

Sets or queries the domain in which the analyzer is triggered.

**Syntax**     :Setup:TriggerDomain { Frequency | Time }  
              :Setup:TriggerDomain?

**Arguments**   Frequency selects the frequency domain for trigger.  
              Time selects the time domain for trigger.

**Examples**     :Setup:TriggerDomain Frequency  
              selects the frequency domain for trigger.

**Related Commands**   :Setup:Trigger

## **:Setup:TriggerInterval (?)**

Sets or queries the time interval for the Interval and Quick Interval trigger modes.

**Syntax**     :Setup:TriggerInterval <value>  
              :Setup:TriggerInterval?

**Arguments**   <value>::=<NR3> ranges 1 s to 3600 s.

**Examples**     :Setup:TriggerInterval 3000  
              sets the time interval for the Interval and Quick Interval trigger modes to 3000 s.

**Related Commands**   :Setup:Trigger

## **:Setup:TriggerPosition (?)**

Sets or query the trigger position.

**Syntax**     :Setup:TriggerPosition <value>  
              :Setup:TriggerPosition?

**Arguments**   <value>::=<NR2> ranges 0 to 100 % in 1 % step.  
                  The trigger position represents the ratio of the number of frames preceding the trigger generation to that of one block.

**Examples**     :Setup:TriggerPosition 10  
                  For example, if the block size is 1,000 frames, 100 frames will be acquired before the trigger generation, and 900 frames after it.

**Related Commands**   :Setup:Trigger

## **:Setup:TriggerSlope (?)**

Selects either a rising or falling edge for the trigger.

**Syntax**     :Setup:TriggerSlope { Rise | Fall }  
              :Setup:TriggerSlope?

**Arguments**   Rise specifies to trigger on the rising or positive edge of a signal.  
                  Fall specifies to trigger on the falling or negative edge of a signal.

**Examples**     :Setup:TriggerSlope Rise  
                  specifies to trigger on the rising edge of a signal.

**Related Commands**   :Setup:Trigger, :Setup:TriggerSource

## **:Setup:TriggerSource (?)**

Selects or queries the trigger source.

**Syntax**     :Setup:TriggerSource { Internal | External }  
              :Setup:TriggerSource?

**Arguments**   Internal uses the trigger mask pattern stored in the internal register for trigger generation.  
  
              External uses the signal from the EXT TRIG connector on the front panel as a trigger input.

**Examples**     :Setup:TriggerSource Internal  
              uses the trigger mask pattern stored in the internal register as the trigger source.

**Related Commands**   :Setup:Trigger

## **:Setup:TriggerTimeout (?)**

Sets or queries the timeout value in the Timeout trigger mode.

**Syntax**     :Setup:TriggerTimeout <value>  
              :Setup:TriggerTimeout?

**Arguments**   <value>::=<NR3> specifies the timeout value. The range is 0 to 60 s.

**Examples**     :Setup:TriggerTimeout 30  
              sets the timeout to 30 s.

**Related Commands**   :Setup:Trigger

**:Setup:TriggerTimes (?)**

Sets or queries the trigger count in the Count trigger mode.

**Syntax** :Setup:TriggerTimes <value>

:Setup:TriggerTimes?

**Arguments** <value>::=<NR1> depends on the FFT points and the memory mode:

FFT points	Memory mode	<value>
256	-	1 to 16000/(Block size)
1024	Frequency	1 to 4000/(Block size)
	Other than Frequency	1 to 2000/(Block size)

**Examples** :Setup:TriggerTimes 10  
sets the trigger count to 10.

**Related Commands** :Setup:Trigger

**:Setup:Version? (Query Only)**

Queries the version of the CDMA Setup program.

**Syntax** :Setup:Version?

**Returns** <NR2> indicates the version number.

**Examples** :Setup:Version?  
might return 1.1.

# Waveform View Commands

When you select Waveform in the Config:View<x> command, use the commands in this section to set the details for the Waveform view.

## **:View<x>:Average:Times (?)**

Sets or queries the number of frames that make up an averaged waveform.

**Syntax**    :View<x>:Average:Times <value>  
              :View<x>:Average:Times?

**Arguments**    <value>::=<NR1> is the number of frames for averaging, from 1 to 1000.

**Examples**    :View1:Average:Times 1000  
              specifies that an averaged waveform will show the result of combining 1000 frames.

**Related Commands**    :View<x>:Average:Type

## **:View<x>:Average:Type (?)**

Selects or queries the average type. You can also select the peak hold mode. For more information about the averaging, refer to the *User Manual*.

**Syntax**    :View<x>:Average:Type { RMSExpo | RMS | PeakHold }  
              :View<x>:Average:Type?

**Arguments**    RMSExpo averages with the RMS (root mean squared) exponential. This mode weights older acquisition data so that they have a progressively smaller effect on the average.

RMS averages with the RMS (root mean squared).

PeakHold holds the peak value for each data point.

**Examples**    :View1:Average:Type RMSExpo  
              averages waveform with the exponential RMS.

**Related Commands**    :View<x>:Average:Time

**:View<x>:Compression (?)**

Selects or queries the display data compression method. It specifies how to take or discard each acquired data point for a corresponding pixel on the screen because the number of horizontal pixels is usually less than that of data points.

**Syntax**     :View<x>:Compression { Sample | MinMax | Max | Min }  
               :View<x>:Compression?

**Arguments**   Sample takes the acquired data points at regular intervals to obtain a waveform display.

              MinMax takes the minimum and the maximum data points for a corresponding pixel. The minimum and the maximum data points are displayed with a vertical bar on the screen.

              Max takes the maximum data point for a corresponding pixel.

              Min takes the minimum data point for a corresponding pixel.

**Examples**     :View1:Compression Sample  
                   takes the acquired data points at regular intervals to obtain a waveform display.

**:View<x>:CopyFrom (No Query Form)**

Loads the display data from the text file.

**Syntax**     :View<x>:CopyFrom <file\_name>

**Arguments**   <file\_name>::=<string> is "\*.TXT" (ASCII text file).  
                   The file is the one to which the display data has been stored with the :View<x>:CopyTo command.

**Examples**     :View1:CopyFrom "SAMPLE1.TXT"  
                   loads the display data from the file SAMPLE1.TXT.

**Related Commands**   :View<x>:CopyTo

## :View<x>:CopyTo (No Query Form)

Stores the display data to a file or data register. This command is effective only for the data acquired in the Vector mode.

**Syntax**     :View<x>:CopyTo { Clipboard | D1 | D2 | D3 | D4 | D5 | D6 | D7 | D8 | <file\_name> }

**Arguments**   Clipboard copies the display data to the Windows clipboard in the ASCII text format. You can use the data in your application.

D1 to D8 are the data register 1 to 8, respectively.

<file\_name>::=<string> is “\*.TXT” (ASCII text file). The extension is set to “.TXT” automatically.

**Examples**     :View1:CopyTo Clipboard  
stores the display data to the clipboard.

**Related Commands**   :View<x>:CopyFrom

## :View<x>:Edit (?)

Determines whether to display the trigger mask on the analyzer screen. Displaying the mask enables you to edit it.

**Syntax**     :View<x>:Edit { On | Off }  
:View<x>:Edit?

**Arguments**   On displays the trigger mask and enables you to edit it.

Off does not display the trigger mask and disables you to edit it.

**Examples**     :View1:Edit On  
displays the trigger mask and enables you to edit it.



**:View<x>:Edit:DrawHorizontal (No Query Form)**

Fills the trigger mask area below the horizontal line on which the marker exists.

**Syntax** :View<x>:Edit:DrawHorizontal

**Arguments** None

**Examples** :View1:Edit:DrawHorizontal  
fills the trigger mask area below the horizontal line on which the marker exists.

**Related Commands** :View<x>:Edit:Y

**:View<x>:Edit:DrawLine (No Query Form)**

Fills the trigger mask area below the line connecting the main marker and the delta marker.

**Syntax** :View<x>:Edit:DrawLine

**Arguments** None

**Examples** :View1:Edit:DrawLine  
fills the trigger mask area below the line connecting the main marker and the delta marker.

**Related Commands** :View<x>:Edit:Y, :View<x>:Marker:ResetDelta

**:View<x>:Edit:DrawMax (No Query Form)**

Fills the trigger mask area below the maximum line i.e. the level 40 dB higher than the reference level.

**Syntax** :View<x>:Edit:DrawMax

**Arguments** None

**Examples** :View1:Edit:DrawMax  
fills the trigger mask area below the maximum line.

**Related Commands** :View<x>:Edit:DrawMin

**:View<x>:Edit:DrawMin (No Query Form)**

Fills the trigger mask area below the minimum line i.e. the level 70 dB lower than the reference level.

**Syntax** :View<x>:Edit:DrawMin

**Arguments** None

**Examples** :View1:Edit:DrawMin  
fills the trigger mask area below the minimum line.

**Related Commands** :View<x>:Edit:DrawMax

**:View<x>:Edit:Y (?)**

Sets or queries the marker vertical position when editing the trigger mask.

**Syntax** :View<x>:Edit:Y <value>  
:View<x>:Edit:Y?

**Arguments** <value>::=<NR3> ranges from the minimum (low) edge to the maximum (high) edge of the the vertical axis.

**Examples** :View1:Edit:Y -50  
places the marker on -50 of the vertical position.

**Related Commands** :View<x>:Edit:DrawHorizontal, :View<x>:Edit:DrawLine

## :View<x>:Format (?)

Selects or queries the waveform display format.

**Syntax** :View<x>:Format { FreqAmpl | FreqPhase | FreqI | FreqQ | TimeAmpl  
| TimePhase | TimeI | TimeQ }

:View<x>:Format?

**Arguments** Defines the parameters associated with the horizontal and vertical axes as follows:

Argument	Horizontal axis	Vertical axis
FreqAmpl	Frequency (span)	Amplitude
FreqPhase	Frequency (span)	Phase
FreqI	Frequency (span)	I (In-Phase)
FreqQ	Frequency (span)	Q (Quadrature-Phase)
TimeAmpl	Time	Amplitude
TimePhase	Time	Phase
TimeI	Time	I (In-Phase)
TimeQ	Time	Q (Quadrature-phase)

**Examples** :View1:Format FreqAmpl  
shows the waveform with frequency along the horizontal axis and amplitude along the vertical axis.

**:View<x>:Marker:Band:Center (?)**

Sets or queries the center frequency of the band marker (the two vertical bar cursors).

**Syntax**     :View<x>:Marker:Band:Center <value>  
              :View<x>:Marker:Band:Center?

**Arguments**   <value>::=<NR3> ranges from the minimum (left) edge to the maximum (right) edge of the the horizontal axis.

**Examples**     :View1:Marker:Band:Center 1G  
                  sets the center frequency of the band marker to 1 GHz.

**Related Commands**   :View<x>:Marker:Band:Left, :View<x>:Marker:Band:Right

**:View<x>:Marker:Band:Left (?)**

Sets or queries the frequency of the left edge of the band marker (the two vertical bar cursors).

**Syntax**     :View<x>:Marker:Band:Left <value>  
              :View<x>:Marker:Band:Left?

**Arguments**   <value>::=<NR3> ranges from the minimum (left) edge to the maximum (right) edge of the the horizontal axis.

**Examples**     :View1:Marker:Band:Left 900M  
                  sets the frequency of the left edge of the band marker to 900 MHz.

**Related Commands**   :View<x>:Marker:Band:Center, :View<x>:Marker:Band:Right

## **:View<x>:Marker:Band:Right (?)**

Sets or queries the frequency of the right edge of the band marker (the two vertical bar cursors).

**Syntax**     :View<x>:Marker:Band:Right <value>  
              :View<x>:Marker:Band:Right?

**Arguments**   <value>::=<NR3> ranges from the minimum (left) edge to the maximum (right) edge of the the horizontal axis.

**Examples**     :View1:Marker:Band:Right 1.1G  
                  sets the frequency of the right edge of the band marker to 1.1 GHz.

**Related Commands**   :View<x>:Marker:Band:Center, :View<x>:Marker:Band:Left

## **:View<x>:Marker:Band:Width (?)**

Sets or queries the bandwidth of the band marker (the two vertical bar cursors).

**Syntax**     :View<x>:Marker:Band:Width <value>  
              :View<x>:Marker:Band:Width?

**Arguments**   <value>::=<NR3> ranges 0 to full-scale of the horizontal axis.

**Examples**     :View1:Marker:Band:Width 50M  
                  sets the bandwidth of the band marker to 50 MHz.

**Related Commands**   :View<x>:Marker:Band:Center, :View<x>:Marker:Band:Left,  
                      :View<x>:Marker:Band:Right

**:View<x>:Marker:DeltaMarker (?)**

Turns the delta marker on or off.

**Syntax**     :View<x>:Marker:DeltaMarker { On | Off }  
              :View<x>:Marker:DeltaMarker?

**Arguments**   On turns the delta marker on.  
              Off turns the delta marker off.

**Examples**     :View1:Marker:DeltaMarker On  
                  turns the delta marker on.

**Related Commands**   :View<x>:Marker:DeltaX, :View<x>:Marker:DeltaY?,  
                      :View<x>:Marker:ResetDelta

**:View<x>:Marker:DeltaX (?)**

Sets or queries the horizontal position of the delta marker.

**Syntax**     :View<x>:Marker:DeltaX <value>  
              :View<x>:Marker:DeltaX?

**Arguments**   <value>::=<NR3> ranges from the minimum (left) edge to the maximum (right) edge of the the horizontal axis.

**Examples**     :View1:Marker:DeltaX 1G  
                  positions the delta marker at 1 GHz.

**Related Commands**   :View<x>:Marker:DeltaY

**:View<x>:Marker:DeltaY? (Query Only)**

Queries the vertical position of the delta marker.

**Syntax** :View<x>:Marker:DeltaY?

**Returns** <NR3>

**Examples** :View1:Marker:DeltaY?  
might return -100, indicating that the delta marker is at -100 dB.

**Related Commands** :View<x>:Marker:DeltaX

**:View<x>:Marker:Peak (No Query Form)**

Moves the marker to the adjacent peak in the specified direction. Note that the adjacent peak is farther than the distance specified with the :View<x>:Marker:SearchSeparation command.

**Syntax** :View<x>:Marker:Peak { 1 | -1 }

**Arguments** 1 moves the marker to the adjacent peak on the left of the marker.  
-1 moves the marker to the adjacent peak on the right of the marker.

**Examples** :View1:Marker:Peak -1  
moves the marker to the adjacent peak on the right of the marker.

**Related Commands** :View<x>:Marker:SearchMax, :View<x>:Marker:SearchMin,  
:View<x>:Marker:SearchSeparation

## **:View<x>:Marker:ResetDelta (No Query Form)**

Moves the delta marker to the main marker position.

**Syntax**     :View<x>:Marker:ResetDelta

**Arguments**   None

**Examples**     :View1:Marker:ResetDelta  
moves the delta marker to the main marker position.

**Related Commands**   :View<x>:Marker:DeltaMarker

## **:View<x>:Marker:SearchMax (No Query Form)**

Positions the marker on the highest signal on screen.

**Syntax**     :View<x>:Marker:SearchMax

**Arguments**   None

**Examples**     :View1:Marker:SearchMax  
positions the marker on the highest signal on screen.

**Related Commands**   :View<x>:Marker:SearchMin



**:View<x>:Marker:SearchMin (No Query Form)**

Positions the marker on the lowest signal on screen.

**Syntax** :View<x>:Marker:SearchMin

**Arguments** None

**Examples** :View1:Marker:SearchMin  
positions the marker on the lowest signal on screen.

**Related Commands** :View<x>:Marker:SearchMax

**:View<x>:Marker:SearchSeparation (?)**

Sets or queries the minimum horizontal distance to separate two peaks.

**Syntax** :View<x>:Marker:SearchSeparation <value>

**Arguments** <value>::=<NR2> specifies the minimum horizontal distance to separate two peaks. The range is 1 to 10 % relative to full-scale.

**Examples** :View1:Marker:SearchSeparation 10  
sets the minimum horizontal distance for peak separation to 10 % relative to full-scale.

**Related Commands** :View<x>:Marker:Peak

**:View<x>:Marker:Trace (?)**

Selects or queries the trace on which the marker is placed.

**Syntax**     :View<x>:Marker:Trace { Trace1 | Trace2 }  
              :View<x>:Marker:Trace?

**Arguments**   Trace1 places the marker on the waveform specified with the :View<x>:Source command.

Trace2 places the marker on the waveform specified with the :View<x>:Trace2:Source command.

**Examples**     :View1:Marker:Trace Trace1  
                 places the marker on the Trace 1.

**Related Commands**   :View<x>:Source, :View<x>:Trace2:Source

**:View<x>:Marker:X (?)**

Sets or queries the horizontal position of the marker.

**Syntax**     :View<x>:Marker:X <value>  
              :View<x>:Marker:X?

**Arguments**   <value>::=<NR3> ranges from the minimum (left) edge to the maximum (right) edge of the the horizontal axis.

**Examples**     :View1:Marker:X 1.5G  
                 positions the marker at 1.5 GHz.

**Related Commands**   :View<x>:Marker:Y?

**:View<x>:Marker:Y? (Query Only)**

Queries the vertical position of the marker.

**Syntax** :View<x>:Marker:Y?

**Returns** <NR3>

**Examples** :View1:Marker:Y?  
might return -30, indicating that the marker is at -30 dBm.

**Related Commands** :View<x>:Marker:X

**:View<x>:MaskVisible (?)**

Determines whether or not to display the trigger mask on the analyzer screen.

**Syntax** :View<x>:MaskVisible { On | Off }  
:View<x>:MaskVisible?

**Arguments** On displays the trigger mask.  
Off hides the trigger mask.

**Examples** :View1:MaskVisible On  
displays the trigger mask.

**:View<x>:Measurement (?)**

Selects or queries the measurement item. The measurement starts with the data acquisition. Query the results with the `:View<x>:Result<y>?` command.

**Syntax** `:View<x>:Measurement { Off | Noise | Power | C/N | C/No | ACP | OBW }`

`:View<x>:Measurement?`

**Arguments** `Off` turns the measurement off.

`Noise` selects the noise measurement.

`Power` selects the power measurement.

`C/N` selects the carrier-to-noise ratio (C/N) measurement.

`C/No` selects the carrier-to-noise density ratio (C/No) measurement.

`ACP` selects the adjacent channel leakage power (ACP) measurement.

`OBW` selects the occupied bandwidth (OBW) measurement.

**Examples** `:View1:Measurement Noise`  
selects the noise measurement.

**Related Commands** `:View<x>:Measurement:ACP:BW`, `:View<x>:Measurement:ACP:SP`,  
`:View<x>:Measurement:OBW`, `:View<x>:Result<y>?`

**:View<x>:Measurement:ACP:BW (?)**

Sets or queries the bandwidth for the ACP measurement.

**Syntax** :View<x>:Measurement:ACP:BW <value>  
:View<x>:Measurement:ACP:BW?

**Arguments** <value>::=<NR3> ranges 0 to full-scale.

**Examples** :View1:Measurement:ACP:BW 1M  
sets the bandwidth for the ACP measurement to 1 MHz.

**Related Commands** :View<x>:Measurement

**:View<x>:Measurement:ACP:Marker (?)**

Selects or queries the band-marker position for the ACP measurement.

**Syntax** :View<x>:Measurement:ACP:Marker { Upper | Center | Lower }  
:View<x>:Measurement:ACP:Marker?

**Arguments** Upper places the band marker to the next higher channel.  
Center places the band marker to the current channel.  
Lower places the band marker to the next lower channel.

**Examples** :View1:Measurement:ACP:Marker Upper  
places the band marker to the next higher channel.

**Related Commands** :View<x>:Measurement

**:View<x>:Measurement:ACP:SP (?)**

Sets or queries the frequency interval between the adjacent channels for the ACP measurement.

**Syntax**     :View<x>:Measurement:ACP:SP <value>  
              :View<x>:Measurement:ACP:SP?

**Arguments**   <value>::=<NR3> ranges 0 to full-scale.

**Examples**     :View1:Measurement:ACP:SP 2M  
                  sets the frequency interval between the adjacent channels to 2 MHz for the ACP measurement.

**Related Commands**   :View<x>:Measurement

**:View<x>:Measurement:OBW (?)**

Sets or queries the occupied bandwidth.

**Syntax**     :View<x>:Measurement:OBW <value>  
              :View<x>:Measurement:OBW?

**Arguments**   <value>::=<NR2> ranges 90 to 99.8 %.

**Examples**     :View1:Measurement:OBW 99.8  
                  sets the occupied bandwidth to 99.8 %.

**Related Commands**   :View<x>:Measurement

**:View<x>:Position (?)**

Specifies or queries which frame in a block to be displayed.

**Syntax**    :View<x>:Position <value>  
               :View<x>:Position?

**Arguments**    <value>::=<NR2> ranges 0 to 100 %. It specifies the display frame position relative to the block size. 0 % specifies that the first frame in a block is displayed. 100 % represents the last frame.

**Examples**    :View1:Position 100  
                   displays the last frame in a block.

**:View<x>:Result<y>? (Query Only)**

Queries the measurement results. Selects the measurement with the :View<x>:Measurement command.

**Syntax**    :View<x>:Result<y>?

**Returns**    <NR3>

Result1 returns the result of the measurement specified with the :View<x>:Measurement command. For the ACP measurement, it returns the lower measurement result.

Result2 returns the ACP upper measurement result.

**Examples**    :View1:Measurement OBW;Result1?  
                   might return 57.36E+03, indicating that the occupied bandwidth is 57.36 kHz.

**Related Commands**    :View<x>:Measurement

**:View<x>:Scale:AutoScale (No Query Form)**

Adjusts the scaling of the vertical axis automatically to best display the data. When the parameter is level or phase, this command sets the vertical axis to full-scale.

**Syntax**     :View<x>:Scale:AutoScale

**Arguments**   None

**Examples**     :View1:Scale:AutoScale  
adjusts the scaling of the vertical axis automatically.

**Related Commands**   :View<x>:Format, :View<x>:Scale:XScale, :View<x>:Scale:YScale

**:View<x>:Scale:HoldYScale (?)**

Determines whether to hold or reset the vertical scale when you change the input source.

**Syntax**     :View<x>:Scale:HoldYScale { On | Off }  
:View<x>:Scale:HoldYScale?

**Arguments**   On holds the vertical scale setting when you change the input source.  
Off resets the vertical scale to full-scale.

**Examples**     :View1:Scale:HoldYScale On  
holds the vertical scale setting when you change the input source.

**Related Commands**   :View<x>:Scale:YScale, :View<x>:Scale:YStart, :View<x>:Source



**:View<x>:Scale:XScale (?)**

Sets or queries the horizontal axis full-scale to display a portion of the data.

**Syntax**    :View<x>:Scale:XScale <value>  
              :View<x>:Scale:XScale?

**Arguments**    <value>::=<NR3> ranges full-scale/256 to full-scale of the acquired data.

**Examples**     :View1:Scale:XScale 2.5M  
                  sets the horizontal axis full-scale to 2.5 MHz.

**Related Commands**    :View<x>:Scale:XStart, :View<x>:Scale:YScale

**:View<x>:Scale:XStart (?)**

Sets or queries the value represented by the minimum (left) edge of the horizontal axis.

**Syntax**        :View<x>:Scale:XStart <value>  
                  :View<x>:Scale:XStart?

**Arguments**    <value>::=<NR3> ranges from the minimum to the maximum value on the horizontal axis of the acquired data.

**Examples**     :View1:Scale:XStart 800M  
                  sets the value represented by the left edge of the horizontal axis to 800 MHz.

**Related Commands**    :View<x>:Scale:XScale

**:View<x>:Scale:YScale (?)**

Sets or queries the vertical axis full-scale to display a portion of the data.

**Syntax**     :View<x>:Scale:YScale <value>  
              :View<x>:Scale:YScale?

**Arguments**   <value>::=<NR3> ranges full-scale/100 to full-scale of the acquired data.

**Examples**     :View1:Scale:YScale 20  
              sets the vertical axis full-scale to 20 dB.

**Related Commands**   :View<x>:Scale:XScale, :View<x>:Scale:YStart

**:View<x>:Scale:YStart (?)**

Sets or queries the value represented by the minimum (bottom) edge of the vertical axis.

**Syntax**     :View<x>:Scale:YStart <value>  
              :View<x>:Scale:YStart?

**Arguments**   <value>::=<NR3> ranges from the reference level – 200 dB to the reference level + 100 dB.

**Examples**     :View1:Scale:YStart -120  
              sets the value represented by the bottom edge of the vertical axis to –120 dB.

**Related Commands**   :View<x>:Scale:YScale

**:View<x>:Source (?)**

Selects or queries the display data source for the specified view.

**Syntax**    :View<x>:Source { None | Active | Average | Zoom | D1D2 |  
D3D4 | D5D6 | D7D8 | D1 | D2 | D3 | D4 | D5 | D6 | D7 | D8 |  
<file\_name> }

:View<x>:Source?

**Arguments**    None specifies no source. The display area in the view will be emptied.

Active specifies the currently acquired data as the source.

Average specifies the averaged data as the source. When you select this item, you have to set the average type and the number of averages using the :View<x>:Average:Type and the :View<x>:Average:Times commands, respectively.

Zoom specifies the zoomed data as the source.

D1D2 to D7D8 specify the register pair D1D2 to D7D8 as the source, respectively.

D1 to D8 specify the data register D1 to D8 as the source, respectively.

<file\_name>::=<string> specifies the file as the source. The file name must be “\*.IQ” (the IQ format) or “\*.AP” (the AP format).

**Examples**    :View1:Source Active  
specifies the currently acquired data as the view source.

**Related Commands**    :Config:Mode, :View<x>:Average:Times, :View<x>:Average:Type

**:View<x>:Trace2:Compression (?)**

Selects or queries the Trace 2 display data compression method i.e. how to take or discard each acquired data point for a corresponding pixel on the screen because the number of horizontal pixels is usually less than that of data points.

**Syntax**     :View<x>:Trace2:Compression { Sample | MinMax | Max | Min }  
              :View<x>:Trace2:Compression?

**Arguments**   **Sa**mple takes the acquired data points at regular intervals to obtain a waveform display.

**Min**Max takes the minimum and the maximum data points for a corresponding pixel. The minimum and the maximum data points are displayed with a vertical bar on the screen.

**Ma**x takes the maximum data point for a corresponding pixel.

**Min** takes the minimum data point for a corresponding pixel.

**Examples**     :View1:Trace2:Compression Sample  
                  takes the acquired data points at regular intervals to obtain a waveform display.

**Related Commands**   :View<x>:Compression, :View<x>:Trace2:Source?

**:View<x>:Trace2:Format (?)**

Selects or queries the display format for the Trace 2.

**Syntax** :View<x>:Trace2:Format { FreqAmpl | FreqPhase | FreqI | FreqQ | TimeAmpl | TimePhase | TimeI | TimeQ }  
:View<x>:Trace2:Format?

**Arguments** Defines the parameters for the horizontal and vertical axes as follows:

Argument	Horizontal axis	Vertical axis
FreqAmpl	Frequency (span)	Amplitude
FreqPhase	Frequency (span)	Phase
FreqI	Frequency (span)	I (In-Phase)
FreqQ	Frequency (span)	Q (Quadrature-Phase)
TimeAmpl	Time	Amplitude
TimePhase	Time	Phase
TimeI	Time	I (In-Phase)
TimeQ	Time	Q (Quadrature-phase)

**Examples** :View1:Trace2:Format FreqAmpl  
shows the Trace 2 waveform with frequency along the horizontal axis and amplitude along the vertical axis.

**Related Commands** :View<x>:Trace2:Source

## **:View<x>:Trace2:Source (?)**

Specifies or queries the display data source for the Trace 2.

**Syntax**     :View<x>:Trace2:Source { None | Active | Zoom | D1D2 |  
D3D4 | D5D6 | D7D8 | D1 | D2 | D3 | D4 | D5 | D6 | D7 | D8 |  
<file\_name> }  
  
:View<x>:Trace2:Source?

**Arguments**   None specifies no source. The display area in the view will be emptied.  
  
Active specifies the currently acquired data as the source.  
  
Zoom specifies the zoomed data as the source.  
  
D1D2 to D7D8 specify the register pair D1D2 to D7D8 as the source, respectively.  
  
D1 to D8 specify the data register D1 to D8 as the source, respectively.  
  
<file\_name>::=<string> specifies the data file as the source. The file name must be “\*.IQ” (the IQ format) or “\*.AP” (the AP format).

**Examples**     :View1:Trace2:Source Active  
specifies the currently acquired data as the source.

**Related Commands**   :Config:Mode, :View<x>:Source

## **:View<x>:Trace2:Z (?)**

Specifies or queries the frame number to be displayed for the Trace 2.

**Syntax**     :View<x>:Trace2:Z <value>  
  
:View<x>:Trace2:Z?

**Arguments**   <value>::=<NR1> ranges 0 to the number of frames – 1.

**Examples**     :View1:Trace2:Z 199  
specifies that the frame 199 displays for the Trace 2.

**Related Commands**   :View<x>:Z

**:View<x>:Version? (Query Only)**

Queries the version of the Waveform View program.

**Syntax** :View<x>:Version?

**Returns** <NR2>

**Examples** :View1:Version?  
might return 1.1.

**:View<x>:Z (?)**

Specifies or queries the displayed frame number.

**Syntax** :View<x>:Z <value>

:View<x>:Z?

**Arguments** <value>::=<NR1> ranges from 0 to the number of frames – 1.

**Examples** :View1:Z 199  
specifies that the frame 199 displays.

**Related Commands** :View<x>:Trace2:Z





# Analog View Commands

When you select Analog in the Config:View<x> command, use the commands in this section to set the details for the Analog view.

## :View<x>:CopyTo (No Query Form)

Stores the display data to a file or data register. This command is effective only for the data acquired in the Vector mode.

**Syntax** :View<x>:CopyTo { Clipboard | D1 | D2 | D3 | D4 | D5 | D6 | D7 | D8 | <file\_name> }

**Arguments** Clipboard stores the display data to the Windows clipboard in the ASCII text format. You can use the data in your application.

D1 to D8 select the data register 1 to 8, respectively.

<file\_name>::=<string> is “\*.TXT” (ASCII text file). The extension is set to “.TXT” automatically.

**Examples** :View1:CopyTo Clipboard  
stores the display data to the clipboard.

## :View<x>:Format (?)

Selects or queries the signal modulation type.

**Syntax** :View<x>:Format { AM | PM | FM }  
:View<x>:Format?

**Arguments** Specifies the modulation type:

Argument	Modulation type	Horizontal axis	Vertical axis
AM	Amplitude modulation	Time	Modulating factor
PM	Phase modulation	Time	Phase
FM	Frequency modulation	Time	Frequency

**Examples** :View1:Format AM  
selects the AM modulation.

## **:View<x>:Marker:DeltaMarker (?)**

Turns the delta marker on or off.

**Syntax**    :View<x>:Marker:DeltaMarker { On | Off }  
              :View<x>:Marker:DeltaMarker?

**Arguments**    On turns the delta marker on.  
                  Off turns the delta marker off.

**Examples**     :View1:Marker:DeltaMarker On  
                  turns the delta marker on.

**Related Commands**    :View<x>:Marker:DeltaX?, :View<x>:Marker:DeltaY?,  
                          :View<x>:Marker:ResetDelta

## **:View<x>:Marker:DeltaX? (Query Only)**

Queries the horizontal position of the delta marker.

**Syntax**     :View<x>:Marker:DeltaX?

**Returns**    <NR3>

**Examples**    :View1:Marker:DeltaX?  
                  might return 3.4E-03, indicating that the delta marker is positioned at 3.4 ms.

**Related Commands**    :View<x>:Marker:DeltaY?

**:View<x>:Marker:DeltaY? (Query Only)**

Queries the vertical position of the delta marker.

**Syntax** :View<x>:Marker:DeltaY?

**Returns** <NR3>

**Examples** :View1:Marker:DeltaY?  
might return -100, indicating that the delta marker is positioned at -100 dB.

**Related Commands** :View<x>:Marker:DeltaX?

**:View<x>:Marker:Peak (No Query Form)**

Moves the marker to the adjacent peak in the specified direction. Note that the adjacent peak is farther than the distance specified with the :View<x>:Marker:SearchSeparation command.

**Syntax** :View<x>:Marker:Peak { 1 | -1 }

**Arguments** 1 moves the marker to the adjacent peak on the left of the marker.  
-1 moves the marker to the adjacent peak on the right of the marker.

**Examples** :View1:Marker:Peak -1  
moves the marker to the adjacent peak on the right of the marker.

**Related Commands** :View<x>:Marker:SearchMax, :View<x>:Marker:SearchMin,  
:View<x>:Marker:SearchSeparation

**:View<x>:Marker:ResetDelta (No Query Form)**

Moves the delta marker to the main marker position.

**Syntax** :View<x>:Marker:ResetDelta

**Arguments** None

**Examples** :View1:Marker:ResetDelta  
moves the delta marker to the main marker position.

**Related Commands** :View<x>:Marker:DeltaMarker

**:View<x>:Marker:SearchMax (No Query Form)**

Positions the marker on the highest signal on screen.

**Syntax** :View<x>:Marker:SearchMax

**Arguments** None

**Examples** :View1:Marker:SearchMax  
positions the marker on the highest signal on screen.

**Related Commands** :View<x>:Marker:SearchMin

**:View<x>:Marker:SearchMin (No Query Form)**

Positions the marker on the lowest signal on screen.

**Syntax** :View<x>:Marker:SearchMin

**Arguments** None

**Examples** :View1:Marker:SearchMin  
positions the marker on the lowest signal on screen.

**Related Commands** :View<x>:Marker:SearchMax

**:View<x>:Marker:SearchSeparation (?)**

Sets or queries the minimum horizontal distance to separate two peaks.

**Syntax** :View<x>:Marker:SearchSeparation <value>

**Arguments** <value>::=<NR2> specifies the minimum horizontal distance to separate two peaks. The range is 1 to 10 % relative to full-scale.

**Examples** :View1:Marker:SearchSeparation 10  
sets the minimum horizontal distance for peak separation to 10 % relative to full-scale.

**Related Commands** :View<x>:Marker:Peak

**:View<x>:Marker:X (?)**

Sets or queries the horizontal position of the marker.

**Syntax** :View<x>:Marker:X <value>  
:View<x>:Marker:X?

**Arguments** <value>::=<NR3> ranges from the minimum (left) edge to the maximum (right) edge of the the horizontal axis.

**Examples** :View1:Marker:X -50u  
positions the marker at -50  $\mu$ s.

**Related Commands** :View<x>:Marker:Y?

**:View<x>:Marker:Y? (Query Only)**

Queries the vertical position of the marker.

**Syntax** :View<x>:Marker:Y?

**Returns** <NR3>

**Examples** :View1:Marker:Y?  
might return 30, indicating that the marker is at 30 % when the modulation type is AM.

**Related Commands** :View<x>:Marker:X

**:View<x>:Scale:AutoScale (No Query Form)**

Adjusts the scaling of the vertical axis automatically to best display the data. When the parameter is level or phase, this command sets the vertical axis to full-scale.

**Syntax** :View<x>:Scale:AutoScale

**Arguments** None

**Examples** :View1:Scale:AutoScale  
adjusts the scaling of the vertical axis automatically.

**Related Commands** :View<x>:Format, :View<x>:Scale:XScale, :View<x>:Scale:YScale

**:View<x>:Scale:HoldYScale (?)**

Determines whether to hold or reset the vertical scale when you change the input source.

**Syntax** :View<x>:Scale:HoldYScale { On | Off }  
:View<x>:Scale:HoldYScale?

**Arguments** On holds the vertical scale setting when you change the input source.  
Off resets the vertical scale to full-scale.

**Examples** :View1:Scale:HoldYScale On  
holds the vertical scale setting when you change the input source.

**Related Commands** :View<x>:Scale:YScale, :View<x>:Scale:YStart, :View<x>:Source



**:View<x>:Scale:XScale (?)**

Sets or queries the horizontal axis full-scale to display a portion of the data.

**Syntax**    :View<x>:Scale:XScale <value>  
              :View<x>:Scale:XScale?

**Arguments** <value>::=<NR3> ranges full-scale/256 to full-scale of the acquired data.

**Examples**    :View1:Scale:XScale 20u  
              sets the horizontal axis full-scale to 20  $\mu$ s.

**Related Commands**    :View<x>:Scale:XStart, :View<x>:Scale:YScale

**:View<x>:Scale:XStart (?)**

Sets or queries the value represented by the minimum (left) edge of the horizontal axis.

**Syntax**    :View<x>:Scale:XStart <value>  
              :View<x>:Scale:XStart?

**Arguments** <value>::=<NR3> ranges from the minimum to the maximum value on the horizontal axis of the acquired data.

**Examples**    :View1:Scale:XStart -50u  
              sets the value represented by the left edge of the horizontal axis to -50  $\mu$ s.

**Related Commands**    :View<x>:Scale:XScale

**:View<x>:Scale:YScale (?)**

Sets or queries the vertical axis full-scale to display a portion of the data.

**Syntax**     :View<x>:Scale:YScale <value>  
              :View<x>:Scale:YScale?

**Arguments**   <value>::=<NR3> ranges full-scale/100 to full-scale of the acquired data.

**Examples**     :View1:Scale:YScale 20  
              sets the vertical axis full-scale to 20 % when the modulation type is AM.

**Related Commands**   :View<x>:Scale:XScale, :View<x>:Scale:YStart

**:View<x>:Scale:YStart (?)**

Sets or queries the value represented by the minimum (bottom) edge of the vertical axis.

**Syntax**     :View<x>:Scale:YStart <value>  
              :View<x>:Scale:YStart?

**Arguments**   <value>::=<NR3> ranges from the reference level – 200 dB to the reference level + 100 dB.

**Examples**     :View1:Scale:YStart -10  
              sets the value represented by the bottom edge of the vertical axis to –10 % when the modulation type is AM.

**Related Commands**   :View<x>:Scale:YScale

**:View<x>:Source (?)**

Selects or queries the display data source for the specified view.

**Syntax**     :View<x>:Source { None | Active | Zoom | D1D2 | D3D4 | D5D6 |  
D7D8 | <file\_name> }  
:View<x>:Source?

**Arguments**   None specifies no source. The display area in the view will be emptied.  
Active specifies the currently acquired data as the source.  
Zoom specifies the zoomed data as the source.  
D1D2 to D7D8 specify the register pair D1D2 to D7D8 as the source, respectively.  
<file\_name>::=<string> specifies the data file as the source. The file name  
must be “\*.IQ” (the IQ format) or “\*.AP” (the AP format).

**Examples**     :View1:Source Active  
specifies the currently acquired data as the view source.

**Related Commands**   :Config:Mode

**:View<x>:Version? (Query Only)**

Queries the version of the Analog View program.

**Syntax**     :View<x>:Version?

**Returns**    <NR2>

**Examples**     :View1:Version?  
might return 1.1.

## **:View<x>:Z (?)**

Specifies or queries the displayed frame number.

**Syntax**    :View<x>:Z <value>  
              :View<x>:Z?

**Arguments**    <value>::=<NR1> ranges from 0 to the number of frames – 1.

**Examples**     :View1:Z 199  
                  specifies that the frame 199 displays.

## FSK View Commands

When you select FSK in the `Config:View<x>` command, use the commands in this section to set the details for the FSK view.

## **:View<x>:CopyTo (No Query Form)**

Stores the display data to a file or data register. This command is effective only for the data acquired in the Vector mode.

**Syntax**     :View<x>:CopyTo { Clipboard | D1 | D2 | D3 | D4 | D5 | D6 | D7 | D8 | <file\_name> }

**Arguments**   Clipboard stores the display data to the Windows clipboard in the ASCII text format. You can use the data in your application.

D1 to D8 selects the data register 1 to 8, respectively.

<file\_name>::=<string> is “\*.TXT” (ASCII text file). The extension is set to “.TXT” automatically.

**Examples**     :View1:CopyTo Clipboard  
stores the display data to the clipboard.

## **:View<x>:Marker:DeltaMarker (?)**

Turns the delta marker on or off.

**Syntax**     :View<x>:Marker:DeltaMarker { On | Off }  
:View<x>:Marker:DeltaMarker?

**Arguments**   On turns the delta marker on.

Off turns the delta marker off

**Examples**     :View1:Marker:DeltaMarker On  
turns the delta marker on.

**Related Commands**   :View<x>:Marker:DeltaX, :View<x>:Marker:DeltaY?,  
:View<x>:Marker:ResetDelta

## **:View<x>:Marker:DeltaX (?)**

Sets or queries the horizontal position of the delta marker.

**Syntax**     :View<x>:Marker:DeltaX <value>  
              :View<x>:Marker:DeltaX?

**Arguments**   <value>::=<NR3> ranges from the minimum (left) edge to the maximum (right) edge of the the horizontal (time) axis.

**Examples**     :View1:Marker:DeltaX 1.2m  
                  positions the delta marker at 1.2 ms.

**Related Commands**   :View<x>:Marker:DeltaY

## **:View<x>:Marker:DeltaY? (Query Only)**

Queries the vertical position of the delta marker.

**Syntax**     :View<x>:Marker:DeltaY?

**Returns**    <NR3>

**Examples**     :View1:Marker:DeltaY?  
                  might return 850.5M, indicating that the delta marker is positioned at 850.5 MHz.

**Related Commands**   :View<x>:Marker:DeltaX?

## **:View<x>:Marker:Peak (No Query Form)**

Moves the marker to the adjacent peak in the specified direction. Note that the adjacent peak is farther than the distance specified with the `:View<x>:Marker:SearchSeparation` command.

**Syntax** `:View<x>:Marker:Peak { 1 | -1 }`

**Arguments** 1 moves the marker to the adjacent peak on the left of the marker.  
-1 moves the marker to the adjacent peak on the right of the marker.

**Examples** `:View1:Marker:Peak -1`  
moves the marker to the adjacent peak on the right of the marker.

**Related Commands** `:View<x>:Marker:SearchMax`, `:View<x>:Marker:SearchMin`,  
`:View<x>:Marker:SearchSeparation`

## **:View<x>:Marker:ResetDelta (No Query Form)**

Moves the delta marker to the main marker position.

**Syntax** `:View<x>:Marker:ResetDelta`

**Arguments** None

**Examples** `:View1:Marker:ResetDelta`

**Related Commands** `:View<x>:Marker:DeltaMarker`

## **:View<x>:Marker:SearchMax (No Query Form)**

Positions the marker on the highest signal on screen.

**Syntax** `:View<x>:Marker:SearchMax`

**Arguments** None



**Examples** :View1:Marker:SearchMax  
positions the marker on the highest signal on screen.

**Related Commands** :View<x>:Marker:SearchMin

### **:View<x>:Marker:SearchMin (No Query Form)**

Positions the marker on the lowest signal on screen.

**Syntax** :View<x>:Marker:SearchMin

**Arguments** None

**Examples** :View1:Marker:SearchMin  
positions the marker on the lowest signal on screen.

**Related Commands** :View<x>:Marker:SearchMax

### **:View<x>:Marker:SearchSeparation (?)**

Sets or queries the minimum horizontal distance to separate two peaks.

**Syntax** :View<x>:Marker:SearchSeparation <value>

**Arguments** <value>::=<NR2> specifies the minimum horizontal distance to separate two peaks. The range is 1 to 10 % relative to full-scale.

**Examples** :View1:Marker:SearchSeparation 10  
sets the minimum horizontal distance for peak separation to 10 % relative to full-scale.

**Related Commands** :View<x>:Marker:Peak

**:View<x>:Marker:X (?)**

Sets or queries the horizontal position of the marker.

**Syntax**    :View<x>:Marker:X <value>  
              :View<x>:Marker:X?

**Arguments**   <value>::=<NR3> ranges from the minimum (left) edge to the maximum (right) edge of the the horizontal (time) axis.

**Examples**    :View1:Marker:X 3.4  
              positions the marker at 3.4 ms.

**Related Commands**   :View<x>:Marker:Y?

**:View<x>:Marker:Y? (Query Only)**

Queries the vertical position of the marker.

**Syntax**    :View<x>:Marker:Y?

**Returns**   <NR3>

**Examples**    :View1:Marker:Y?  
              might return 543.2M, indicating that the marker is positioned at 543.2 MHz.

**Related Commands**   :View<x>:Marker:X

**:View<x>:Scale:AutoScale (No Query Form)**

Adjusts the scaling of the vertical (frequency) axis automatically to best display the data.

**Syntax**    :View<x>:Scale:AutoScale

**Arguments**   None

**Examples**     :View1:Scale:AutoScale  
adjusts the scaling of the vertical axis automatically.

**Related Commands**     :View<x>:Scale:XScale, :View<x>:Scale:YScale

## :View<x>:Scale:HoldYScale (?)

Determines whether to hold or reset the vertical scale when you change the input source.

**Syntax**     :View<x>:Scale:HoldYScale { On | Off }  
:View<x>:Scale:HoldYScale?

**Arguments**     On holds the vertical scale setting when you change the input source.  
Off resets the vertical scale to full-scale.

**Examples**     :View1:Scale:HoldYScale On  
holds the vertical scale setting when you change the input source.

**Related Commands**     :View<x>:Scale:YScale, :View<x>:Scale:YStart, :View<x>:Source

## :View<x>:Scale:XScale (?)

Sets or queries the horizontal axis full-scale to display a portion of the data.

**Syntax**     :View<x>:Scale:XScale <value>  
:View<x>:Scale:XScale?

**Arguments**     <value>::=<NR3> ranges full-scale/256 to full-scale of the acquired data.

**Examples**     :View1:Scale:XScale 20u  
sets the horizontal axis full-scale to 20  $\mu$ s.

**Related Commands**     :View<x>:Scale:XStart, :View<x>:Scale:YScale

**:View<x>:Scale:XStart (?)**

Sets or queries the value represented by the minimum (left) edge of the horizontal (time) axis.

**Syntax**     :View<x>:Scale:XStart <value>  
              :View<x>:Scale:XStart?

**Arguments**   <value>::=<NR3> ranges from the minimum to the maximum value on the horizontal axis of the acquired data.

**Examples**     :View1:Scale:XStart -50u  
                  sets the value represented by the left edge of the horizontal axis to -50  $\mu$ s.

**Related Commands**   :View<x>:Scale:XScale

**:View<x>:Scale:YScale (?)**

Sets or queries the vertical axis full-scale to display a portion of the data.

**Syntax**     :View<x>:Scale:YScale <value>  
              :View<x>:Scale:YScale?

**Arguments**   <value>::=<NR3> ranges full-scale/100 to full-scale of the acquired data.

**Examples**     :View1:Scale:YScale 10M  
                  sets the vertical axis full-scale to 10 MHz.

**Related Commands**   :View<x>:Scale:XScale, :View<x>:Scale:YStart

**:View<x>:Scale:YStart (?)**

Sets or queries the value represented by the minimum (bottom) edge of the vertical axis.

**Syntax**    :View<x>:Scale:YStart <value>  
               :View<x>:Scale:YStart?

**Arguments**    <value>::=<NR3> ranges from the minimum to the maximum value on the vertical axis of the acquired data.

**Examples**        :View1:Scale:YStart -5M  
                       sets the value represented by the bottom edge of the vertical axis to -5 MHz.

**Related Commands**    :View<x>:Scale:YScale

**:View<x>:Source (?)**

Selects or queries the display data source for the specified view.

**Syntax**        :View<x>:Source { None | Active | Zoom | D1D2 | D3D4 | D5D6 |  
                   D7D8 | <file\_name> }  
                   :View<x>:Source?

**Arguments**        None specifies no source. The display area in the view will be emptied.  
                       Active specifies the currently acquired data as the source.  
                       Zoom specifies the zoomed data as the source.  
                       D1D2 to D7D8 specify the register pair D1D2 to D7D8 as the source, respectively.  
                       <file\_name>::=<string> specifies the data file as the source. The file name  
                       must be “\*.IQ” (the IQ format) or “\*.AP” (the AP format).

**Examples**        :View1:Source Active  
                       specifies the currently acquired data as the view source.

**Related Commands**    :Config:Mode

**:View<x>:Version? (Query Only)**

Queries the version of the FSK View program.

**Syntax** :View<x>:Version?

**Returns** <NR2>

**Examples** :View1:Version?  
might return 1.1.

**:View<x>:Z (?)**

Specifies or queries the displayed frame number.

**Syntax** :View<x>:Z <value>

:View<x>:Z?

**Arguments** <value>::=<NR1> ranges from 0 to the number of frames – 1.

**Examples** :View1:Z 199  
specifies that the frame 199 displays.

# Spectrogram View Commands

When you select Spectrogram in the `Config:View<x>` command, use the commands in this section to control the Spectrogram view.

**:View<x>:Compression (?)**

Selects or queries the display data compression method. It specifies how to take or discard each acquired data point for a corresponding pixel on the screen because the number of horizontal pixels is usually less than that of data points.

**Syntax**    :View<x>:Compression { Sample | Max | Min }  
               :View<x>:Compression?

**Arguments**    Sample takes the acquired data points at regular intervals to obtain a waveform display.  
                   Max takes the maximum data point for a corresponding pixel.  
                   Min takes the minimum data point for a corresponding pixel.

**Examples**      :View1:Compression Sample  
                   takes the acquired data points at regular intervals to obtain a spectrogram display.

**:View<x>:Format (?)**

Selects or queries the waveform display format.

**Syntax**        :View<x>:Format { FreqAmpl | FreqPhase }  
                   :View<x>:Format?

**Arguments**    Defines the parameters associated with the horizontal axis, vertical axis, and colors as follows:

Argument	Horizontal axis	Vertical (Z) axis	Color
FreqAmpl	Frequency	Frame number	Amplitude
FreqPhase	Frequency	Frame number	Phase

**Examples**      :View1:Format FreqAmpl  
                   shows frame-by-frame time-series spectrum along the vertical axis. In each spectrum, the horizontal axis represents frequency and the color represents amplitude.



**:View<x>:Marker:DeltaMarker (?)**

Turns the delta marker on or off.

**Syntax** :View<x>:Marker:DeltaMarker { On | Off }  
:View<x>:Marker:DeltaMarker?

**Arguments** On turns the delta marker on.  
Off turns the delta marker off

**Examples** :View1:Marker:DeltaMarker On  
turns the delta marker on.

**Related Commands** :View<x>:Marker:DeltaX, :View<x>:Marker:DeltaY?,  
:View<x>:Marker:DeltaZ, :View<x>:Marker:ResetDelta

**:View<x>:Marker:DeltaT? (Query Only)**

Queries the delta-marker position on the Z (frame number) axis as the time.

**Syntax** :View<x>:Marker:DeltaT?

**Returns** <NR3>

**Examples** :View1:Marker:DeltaT?  
might return 0.0096, indicating that the delta marker is positioned at 0.0096 s.

**Related Commands** :View<x>:Marker:DeltaMarker?, :View<x>:Marker:DeltaZ

**:View<x>:Marker:DeltaX (?)**

Sets or queries the horizontal position of the delta marker.

**Syntax**     :View<x>:Marker:DeltaX <value>  
              :View<x>:Marker:DeltaX?

**Arguments**   <value>::=<NR3> ranges from the minimum (left) edge to the maximum (right) edge of the horizontal (frequency) axis.

**Examples**     :View1:Marker:DeltaX 1.2G  
                  positions the delta marker at 1.2 GHz.

**Related Commands**   :View<x>:Marker:DeltaY?, :View<x>:Marker:DeltaZ,  
                          :View<x>:Marker:ResetDelta

**:View<x>:Marker:DeltaY? (Query Only)**

Queries the delta-marker position on the Y (color) axis.

**Syntax**     :View<x>:Marker:DeltaY?

**Returns**    <NR3>

**Examples**     :View1:Marker:DeltaY?  
                  might return -12.3, indicating that the delta marker is positioned at -12.3 dBm.

**Related Commands**   :View<x>:Marker:DeltaX, :View<x>:Marker:DeltaZ,  
                          :View<x>:Marker:ResetDelta

**:View<x>:Marker:DeltaZ (?)**

Sets or queries the delta-marker position on the Z (frame number) axis.

**Syntax**     :View<x>:Marker:DeltaZ <value>  
              :View<x>:Marker:DeltaZ?

**Arguments** <value>::=<NR1> ranges 0 to the number of frames – 1.

**Examples** :View1:Marker:DeltaZ 199  
positions the delta marker at 199 of the frame number.

**Related Commands** :View<x>:Marker:DeltaX, :View<x>:Marker:DeltaY?,  
:View<x>:Marker:ResetDelta

## **:View<x>:Marker:Peak (No Query Form)**

Moves the marker to the adjacent peak in the specified direction. Note that the adjacent peak is farther than the distance specified with the :View<x>:Marker:SearchSeparation command.

**Syntax** :View<x>:Marker:Peak { 1 | -1 }

**Arguments** 1 moves the marker to the adjacent peak on the left of the marker.  
-1 moves the marker to the adjacent peak on the right of the marker.

**Examples** :View1:Marker:Peak -1  
moves the marker to the adjacent peak on the right of the marker.

**Related Commands** :View<x>:Marker:SearchMax, :View<x>:Marker:SearchMin,  
:View<x>:Marker:SearchSeparation

## **:View<x>:Marker:ResetDelta (No Query Form)**

Moves the delta marker to the main marker position.

**Syntax** :View<x>:Marker:ResetDelta

**Arguments** None

**Examples** :View1:Marker:ResetDelta

**Related Commands** :View<x>:Marker:DeltaMarker

**:View<x>:Marker:SearchMax (No Query Form)**

Positions the marker on the highest signal on screen.

**Syntax** :View<x>:Marker:SearchMax

**Arguments** None

**Examples** :View1:Marker:SearchMax  
positions the marker on the highest signal on screen.

**Related Commands** :View<x>:Marker:SearchMin

**:View<x>:Marker:SearchMin (No Query Form)**

Positions the marker on the lowest signal on screen.

**Syntax** :View<x>:Marker:SearchMin

**Arguments** None

**Examples** :View1:Marker:SearchMin  
positions the marker on the lowest signal on screen.

**Related Commands** :View<x>:Marker:SearchMax

**:View<x>:Marker:SearchSeparation (?)**

Sets or queries the minimum horizontal distance to separate two peaks.

**Syntax** :View<x>:Marker:SearchSeparation <value>

**Arguments** <value>::=<NR2> specifies the minimum horizontal distance to separate two peaks. The range is 1 to 10 % relative to full-scale.

**Examples**     :View1:Marker:SearchSeparation 10  
sets the minimum horizontal distance for peak separation to 10 % relative to full-scale.

**Related Commands**     :View<x>:Scale:XScale

## :View<x>:Marker:T? (Query Only)

Queries the marker position on the Z (frame number) axis as the time.

**Syntax**     :View<x>:Marker:T?

**Returns**     <NR3>

**Examples**     :View1:Marker:T?  
might return 0.005827, indicating that the delta marker is positioned at 5.827 ms.

**Related Commands**     :View<x>:Marker:Z

## :View<x>:Marker:X (?)

Sets or queries the horizontal position of the marker.

**Syntax**     :View<x>:Marker:X <value>

              :View<x>:Marker:X?

**Arguments**     <value>::=<NR3> ranges from the minimum (left) edge to the maximum (right) edge of the the horizontal (frequency) axis.

**Examples**     :View1:Marker:X 1.2G  
positions the marker at 1.2 GHz.

**Related Commands**     :View<x>:Marker:Y?, :View<x>:Marker:Z

**:View<x>:Marker:Y? (Query Only)**

Queries the marker position on the Y (color) axis.

**Syntax** :View<x>:Marker:Y?

**Returns** <NR3>

**Examples** :View1:Marker:Y?  
might return -12.3, indicating that the marker is positioned at -12.3 dBm when the Y axis represents amplitude.

**Related Commands** :View<x>:Marker:X, :View<x>:Marker:Z

**:View<x>:Marker:Z (?)**

Sets or queries the marker position on the vertical (frame number) axis.

**Syntax** :View<x>:Marker:Z <value>

:View<x>:Marker:Z?

**Arguments** <value>::=<NR1> ranges 0 to the number of frames - 1.

**Examples** :View1:Marker:Z 199  
positions the marker at 199 of the frame number.

**Related Commands** :View<x>:Marker:X, :View<x>:Marker:Y?

**:View<x>:Monochrome (?)**

Determines whether to display spectrogram in monochrome.

**Syntax** :View<x>:Monochrome { On | Off }

:View<x>:Monochrome?

**Arguments** On displays spectrogram in monochrome.  
Off displays spectrogram in color.

**Examples** :View1:Monochrome On  
displays spectrogram in monochrome.

## **:View<x>:NumberColors (?)**

Selects or queries the number of display colors.

**Syntax** :View<x>:NumberColors { 10 | 100 }  
:View<x>:NumberColors?

**Arguments** 10 selects 10-color display (same as the system software version 1.6 or before).  
100 selects 100-color display (default).

**Examples** :View1:NumberColors 100  
selects 100 color display.

**Related Commands** :View<x>:Scale:YScale, :View<x>:Scale:YStart

## **:View<x>:Scale:AutoScale (No Query Form)**

Adjusts the scaling of the Y (color) axis automatically to best display the data. In the Spectrogram view, this command displays data in full-scale.

**Syntax** :View<x>:Scale:AutoScale

**Arguments** None

**Examples** :View1:Scale:AutoScale  
adjusts the scaling of the Y axis automatically.

**Related Commands** :View<x>:Scale:YScale

**:View<x>:Scale:HoldYScale (?)**

Determines whether to hold or reset the Y (color) axis scale when you change the input source.

**Syntax**     :View<x>:Scale:HoldYScale { On | Off }  
              :View<x>:Scale:HoldYScale?

**Arguments**   On holds the Y axis scale setting when you change the input source.  
              Off resets the Y axis scale to full-scale.

**Examples**     :View1:Scale:HoldYScale On  
              holds the vertical scale setting when you change the input source.

**Related Commands**   :View<x>:Scale:YScale, :View<x>:Scale:YStart, :View<x>:Source

**:View<x>:Scale:XScale (?)**

Sets or queries the horizontal (frequency) axis full-scale to display a portion of the data.

**Syntax**     :View<x>:Scale:XScale <value>  
              :View<x>:Scale:XScale?

**Arguments**   <value>::=<NR3> ranges full-scale/256 to full-scale of the acquired data.

**Examples**     :View1:Scale:XScale 2.5M  
              sets the horizontal axis full-scale to 2.5 MHz.

**Related Commands**   :View<x>:Scale:XStart, :View<x>:Scale:YScale



**:View<x>:Scale:XStart (?)**

Sets or queries the value represented by the minimum (left) edge of the horizontal (frequency) axis.

**Syntax**    :View<x>:Scale:XStart <value>  
              :View<x>:Scale:XStart?

**Arguments**    <value>::=<NR3> ranges from the minimum to the maximum value on the horizontal axis of the acquired data.

**Examples**     :View1:Scale:XStart 543.2M  
                  sets the value represented by the left edge of the horizontal axis to 543.2 MHz.

**Related Commands**    :View<x>:Scale:XScale

**:View<x>:Scale:YScale (?)**

Sets or queries the Y (color) axis full-scale to display a portion of the data.

**Syntax**        :View<x>:Scale:YScale <value>  
                  :View<x>:Scale:YScale?

**Arguments**    <value>::=<NR3> ranges full-scale/100 to full-scale of the acquired data.

**Examples**     :View1:Scale:YScale 2  
                  sets the Y axis full-scale to 2 dB when the axis represents the amplitude.

**Related Commands**    :View<x>:Scale:XScale

**:View<x>:Scale:YStart (?)**

Sets or queries the value represented by the minimum (bottom) edge of the Y (color) axis.

**Syntax**     :View<x>:Scale:YStart <value>  
              :View<x>:Scale:YStart?

**Arguments**   <value>::=<NR3> ranges from the minimum to the maximum value on the Y axis of the acquired data.

**Examples**     :View1:Scale:YStart -12.5  
                  sets the value represented by the bottom edge of the Y axis to -12.5 dBm.

**Related Commands**   :View<x>:Scale:YScale

**:View<x>:Scale:ZScale (?)**

Sets or queries the frame display interval. The spectrogram is displayed every specified number of frames.

**Syntax**     :View<x>:Scale:ZScale <value>  
              :View<x>:Scale:ZScale?

**Arguments**   <value>::=<NR1> ranges 1 to 32.  
                  1 means every frame is displayed. 32 means every 32<sup>th</sup> frame is displayed.

**Examples**     :View1:Scale:ZScale 8  
                  displays the spectrogram every 8<sup>th</sup> frame.

**Related Commands**   :View<x>:Scale:ZStart

**:View<x>:Scale:ZStart (?)**

Sets or queries the value represented by the minimum (bottom) edge of the Z (frame number) axis, i.e. the first frame to be displayed.

**Syntax**    :View<x>:Scale:ZStart <value>  
               :View<x>:Scale:ZStart?

**Arguments**    <value>::=<NR1> ranges from 0 to the number of frames – 1.

**Examples**        :View1:Scale:ZStart 20  
                       sets the value represented by the bottom edge of the Z axis to 20.

**Related Commands**    :View<x>:Scale:ZScale

**:View<x>:Source (?)**

Selects or queries the display data source for the specified view.

**Syntax**        :View<x>:Source { None | Active | Zoom | D1 | D2 | D3 | D4 | D5 |  
                       D6 | D7 | D8 | <file\_name> }  
                       :View<x>:Source?

**Arguments**    None specifies no source. The display area in the view will be emptied.

Active specifies the currently acquired data as the source.

Zoom specifies the zoomed data as the source.

D1 to D8 specify the register D1 to D8 as the source, respectively.

<file\_name>::=<string> specifies the data file as the source. The file name must be “\*.IQ” (the IQ format) or “\*.AP” (the AP format).

**Examples**        :View1:Source Active  
                       specifies the currently acquired data as the view source.

**Related Commands**    :Config:Mode

**:View<x>:Version? (Query Only)**

Queries the version of the Spectrogram View program.

**Syntax** :View<x>:Version?

**Returns** <NR2>

**Examples** :View1:Version?  
might return 1.1.

**:View<x>:ZGap (?)**

Sets or queries the display interval between two adjacent frames on the Z (frame number) axis.

**Syntax** :View<x>:ZGap <value>  
:View<x>:ZGap?

**Arguments** <value>::=<NR1> ranges 1 to 10 pixels.

**Examples** :View1:ZGap 10  
sets the display interval between two adjacent frames on the Z axis to 10 pixels.

# Waterfall View Commands

When you select `Waterfall` in the `:Config:View<x>` command, use the commands in this section to control the Waterfall view.

## **:View<x>:Compression (?)**

Selects or queries the display data compression method. It specifies how to take or discard each acquired data point for a corresponding pixel on the screen because the number of horizontal pixels is usually less than that of data points.

**Syntax**     :View<x>:Compression { Sample | MinMax | Max | Min }  
              :View<x>:Compression?

**Arguments**   **Samp**le takes the acquired data points at regular intervals to obtain a waveform display.

**Min**Max takes the minimum and the maximum data points for a corresponding pixel. The minimum and the maximum data points are displayed with a vertical bar on the screen.

**Max** takes the maximum data point for a corresponding pixel.

**Min** takes the minimum data point for a corresponding pixel.

**Examples**     :View1:Compression **Samp**le  
                  takes the acquired data points at regular intervals to obtain a waveform display.

**:View<x>:Format (?)**

Selects or queries the waveform display format.

**Syntax**    :View<x>:Format { FreqAmpl | FreqPhase | FreqI | FreqQ | TimeAmpl  
| TimePhase | TimeI | TimeQ }  
  
:View<x>:Format?

**Arguments**    Defines the parameters associated with the horizontal and vertical axes as follows:

Argument	Horizontal axis	Vertical axis
FreqAmpl	Frequency (span)	Amplitude
FreqPhase	Frequency (span)	Phase
FreqI	Frequency (span)	I (In-Phase)
FreqQ	Frequency (span)	Q (Quadrature-Phase)
TimeAmpl	Time	Amplitude
TimePhase	Time	Phase
TimeI	Time	I (In-Phase)
TimeQ	Time	Q (Quadrature-phase)

**Examples**    :View1:Format FreqAmpl  
shows the waveform, with the frequency along the horizontal axis, and the amplitude along the vertical axis.

**:View<x>:Marker:DeltaMarker (?)**

Turns the delta marker on or off.

**Syntax**    :View<x>:Marker:DeltaMarker { On | Off }  
              :View<x>:Marker:DeltaMarker?

**Arguments**    On turns the delta marker on.  
                  Off turns the delta marker off

**Examples**     :View1:Marker:DeltaMarker On  
                  turns the delta marker on.

**Related Commands**    :View<x>:Marker:DeltaX, :View<x>:Marker:DeltaY?,  
                          :View<x>:Marker:DeltaZ, :View<x>:Marker:ResetDelta

**:View<x>:Marker:DeltaT? (Query Only)**

Queries the delta marker position on the Z (frame number) axis as the time.

**Syntax**        :View<x>:Marker:DeltaT?

**Returns**        <NR3>

**Examples**     :View1:Marker:DeltaT?  
                  might return 0.0096, indicating that the delta marker is positioned at 0.0096 s.

**Related Commands**    :View<x>:Marker:DeltaMarker, :View<x>:Marker:DeltaZ



## **:View<x>:Marker:DeltaX (?)**

Sets or queries the horizontal position of the delta marker.

**Syntax**     :View<x>:Marker:DeltaX <value>  
              :View<x>:Marker:DeltaX?

**Arguments**   <value>::=<NR3> ranges from the minimum (left) edge to the maximum (right) edge of the the horizontal axis.

**Examples**     :View1:Marker:DeltaX 1.2G  
                  positions the delta marker at 1.2 GHz.

**Related Commands**   :View<x>:Marker:DeltaY?, :View<x>:Marker:DeltaZ,  
                      :View<x>:Marker:ResetDelta

## **:View<x>:Marker:DeltaY? (Query Only)**

Queries the delta-marker position on the vertical axis.

**Syntax**     :View<x>:Marker:DeltaY?

**Returns**    <NR3>

**Examples**     :View1:Marker:DeltaY?  
                  might return -12.3, indicating that the delta marker is positioned at -12.3 dBm.

**Related Commands**   :View<x>:Marker:DeltaX, :View<x>:Marker:DeltaZ,  
                      :View<x>:Marker:ResetDelta

**:View<x>:Marker:DeltaZ (?)**

Sets or queries the delta-marker position on the Z (frame number) axis.

**Syntax**     :View<x>:Marker:DeltaZ <value>  
              :View<x>:Marker:DeltaZ?

**Arguments**   <value>::=<NR1> ranges 0 to the number of frames – 1.

**Examples**     :View1:Marker:DeltaZ 199  
                  positions the delta marker at 199 of the frame number.

**Related Commands**   :View<x>:Marker:DeltaX, :View<x>:Marker:DeltaY?,  
                      :View<x>:Marker:ResetDelta

**:View<x>:Marker:Peak (No Query Form)**

Moves the marker to the adjacent peak in the specified direction. Note that the adjacent peak is farther than the distance specified with the :View<x>:Marker:SearchSeparation command.

**Syntax**     :View<x>:Marker:Peak { 1 | -1 }

**Arguments**   1 moves the marker to the adjacent peak on the left of the marker.  
              -1 moves the marker to the adjacent peak on the right of the marker.

**Examples**     :View1:Marker:Peak -1  
                  moves the marker to the adjacent peak on the right of the marker.

**Related Commands**   :View<x>:Marker:SearchMax, :View<x>:Marker:SearchMin,  
                      :View<x>:Marker:SearchSeparation

**:View<x>:Marker:ResetDelta (No Query Form)**

Moves the delta marker to the main marker position.

**Syntax** :View<x>:Marker:ResetDelta

**Arguments** None

**Examples** :View1:Marker:ResetDelta  
moves the delta marker to the main marker position.

**Related Commands** :View<x>:Marker:DeltaMarker

**:View<x>:Marker:SearchMax (No Query Form)**

Positions the marker on the highest signal on screen.

**Syntax** :View<x>:Marker:SearchMax

**Arguments** None

**Examples** :View1:Marker:SearchMax  
positions the marker on the highest signal on screen.

**Related Commands** :View<x>:Marker:SearchMin

**:View<x>:Marker:SearchMin (No Query Form)**

Positions the marker on the lowest signal on screen.

**Syntax** :View<x>:Marker:SearchMin

**Arguments** None

**Examples** :View1:Marker:SearchMin  
positions the marker on the lowest signal on screen.

**Related Commands** :View<x>:Marker:SearchMax

**:View<x>:Marker:SearchSeparation (?)**

Sets or queries the minimum horizontal distance to separate two peaks.

**Syntax** :View<x>:Marker:SearchSeparation <value>

**Arguments** <value>::=<NR2> specifies the minimum horizontal distance to separate two peaks. The range is 1 to 10 % relative to full-scale.

**Examples** :View1:Marker:SearchSeparation 10  
sets the minimum horizontal distance for peak separation to 10 % relative to full-scale.

**Related Commands** :View<x>:Scale:XScale

**:View<x>:Marker:T? (Query Only)**

Queries the marker position on the Z (frame number) axis as the time.

**Syntax** :View<x>:Marker:T?

**Returns** <NR3>

**Examples** :View1:Marker:T?  
might return 0.0096, indicating that the marker is at 0.0096 s.

**Related Commands** :View<x>:Marker:Z

**:View<x>:Marker:X (?)**

Sets or queries the horizontal position of the marker.

**Syntax** :View<x>:Marker:X <value>

:View<x>:Marker:X?

**Arguments** <value>::=<NR3> ranges from the minimum (left) edge to the maximum (right) edge of the the horizontal axis.

**Examples** :View1:Marker:X 1.2G  
positions the marker at 1.2 GHz.

**Related Commands** :View<x>:Marker:Y?, :View<x>:Marker:Z

**:View<x>:Marker:Y? (Query Only)**

Queries the marker position on the vertical axis.

**Syntax** :View<x>:Marker:Y?

**Returns** <NR3>

**Examples** :View1:Marker:Y?  
might return -12.3, indicating that the marker is positioned at -12.3 dBm.

**Related Commands** :View<x>:Marker:X, :View<x>:Marker:Z

**:View<x>:Marker:Z (?)**

Sets or queries the marker position on the Z (frame number) axis.

**Syntax** :View<x>:Marker:Z <value>

:View<x>:Marker:Z?

**Arguments** <value>::=<NR1> ranges 0 to the number of frames - 1.

**Examples** :View1:Marker:Z 199  
positions the marker at 199 of the frame number.

**Related Commands** :View<x>:Marker:X, :View<x>:Marker:Y?

## **:View<x>:Scale:AutoScale (No Query Form)**

Adjusts the scaling of the vertical axis automatically to best display the data. When the parameter is level or phase, this command sets the vertical axis to full-scale.

**Syntax**     :View<x>:Scale:AutoScale

**Arguments**   None

**Examples**     :View1:Scale:AutoScale  
adjusts the scaling of the vertical axis automatically.

**Related Commands**   :View<x>:Scale:XScale, :View<x>:Scale:YScale

## **:View<x>:Scale:HoldYScale (?)**

Determines whether to hold or reset the vertical scale when you change the input source.

**Syntax**     :View<x>:Scale:HoldYScale { On | Off }  
:View<x>:Scale:HoldYScale?

**Arguments**   On holds the vertical scale setting when you change the input source.  
Off resets the vertical scale to full-scale.

**Examples**     :View1:Scale:HoldYScale On  
holds the vertical scale setting when you change the input source.

**Related Commands**   :View<x>:Scale:YScale, :View<x>:Scale:YStart, :View<x>:Source

**:View<x>:Scale:XScale (?)**

Sets or queries the horizontal axis full-scale to display a portion of the data.

**Syntax**     :View<x>:Scale:XScale <value>  
              :View<x>:Scale:XScale?

**Arguments**   <value>::=<NR3> ranges full-scale/256 to full-scale of the acquired data.

**Examples**     :View1:Scale:XScale 2.5M  
              sets the horizontal axis full-scale to 2.5 MHz.

**Related Commands**   :View<x>:Scale:XStart, :View<x>:Scale:YScale

**:View<x>:Scale:XStart (?)**

Sets or queries the value represented by the minimum (left) edge of the horizontal axis.

**Syntax**     :View<x>:Scale:XStart <value>  
              :View<x>:Scale:XStart?

**Arguments**   <value>::=<NR3> ranges from the minimum to the maximum value on the horizontal axis of the acquired data.

**Examples**     :View1:Scale:XStart 543.2M  
              sets the value represented by the left edge of the horizontal axis to 543.2 MHz.

**Related Commands**   :View<x>:Scale:XScale



**:View<x>:Scale:YScale (?)**

Sets or queries the vertical axis full-scale to display a portion of the data.

**Syntax**    :View<x>:Scale:YScale <value>  
              :View<x>:Scale:YScale?

**Arguments**    <value>::=<NR3> ranges full-scale/100 to full-scale of the acquired data.

**Examples**     :View1:Scale:YScale 2  
                  sets the vertical axis full-scale to 2 dB.

**Related Commands**    :View<x>:Scale:XScale, :View<x>:Scale:YStart

**:View<x>:Scale:YStart (?)**

Sets or queries the value represented by the minimum (bottom) edge of the vertical axis.

**Syntax**        :View<x>:Scale:YStart <value>  
                  :View<x>:Scale:YStart?

**Arguments**    <value>::=<NR3> ranges from the minimum to the maximum value on the vertical axis of the acquired data.

**Examples**     :View1:Scale:YStart -12.5  
                  sets the value represented by the bottom edge of the vertical axis to -12.5 dBm.

**Related Commands**    :View<x>:Scale:YScale

**:View<x>:Scale:ZScale (?)**

Sets or queries the frame display interval. The waveform is displayed every specified number of frames.

**Syntax**     :View<x>:Scale:ZScale <value>  
              :View<x>:Scale:ZScale?

**Arguments**   <value>::=<NR1> ranges 1 to 32.  
                  1 means every frame is displayed. 32 means every 32<sup>th</sup> frame is displayed.

**Examples**     :View1:Scale:ZScale 8  
                  displays the waveform every 8<sup>th</sup> frame.

**Related Commands**   :View<x>:Scale:ZStart

**:View<x>:Scale:ZStart (?)**

Specifies or queries the first frame to be displayed.

**Syntax**     :View<x>:Scale:ZStart <value>  
              :View<x>:Scale:ZStart?

**Arguments**   <value>::=<NR1> ranges 0 to the number of frames – 1.

**Examples**     :View1:Scale:ZStart 20  
                  displays the waveform starting from the frame number 20.

**Related Commands**   :View<x>:Scale:ZScale

**:View<x>:Source (?)**

Selects or queries the display data source for the specified view.

**Syntax**    :View<x>:Source { None | Active | Zoom | D1 | D2 | D3 | D4 | D5 | D6 | D7 | D8 | <file\_name> }  
               :View<x>:Source?

**Arguments**    None specifies no source. The display area in the view will be emptied.  
                   Active specifies the currently acquired data as the source.  
                   Zoom specifies the zoomed data as the source.  
                   D1 to D8 specify the data register D1 to D7 as the source, respectively.  
                   <file\_name>::=<string> specifies the data file as the source. The file name must be “\*.IQ” (the IQ format) or “\*.AP” (the AP format).

**Examples**     :View1:Source Active  
                   specifies the currently acquired data as the view source.

**Related Commands**    :Config:Mode

**:View<x>:Version? (Query Only)**

Queries the version of the Waterfall View program.

**Syntax**     :View<x>:Version?

**Returns**    <NR2>

**Examples**    :View1:Version?  
                   might return 1.1.

**:View<x>:YHeight (?)**

Sets or queries the full-scale of the vertical axis in pixels.

**Syntax**    :View<x>:YHeight <value>  
              :View<x>:YHeight?

**Arguments**   <value>::=<NR1> ranges 1 to 100 pixels.

**Examples**    :View1:YHeight 100  
              sets the full-scale of the vertical axis to 100 pixels.

**Related Commands**   :View<x>:ZGap

**:View<x>:ZGap (?)**

Sets or queries the frame interval for the Waterfall display.

**Syntax**    :View<x>:ZGap <value>  
              :View<x>:ZGap?

**Arguments**   <value>::=<NR1> ranges 1 to 100 pixels.

**Examples**    :View1:ZGap 100  
              sets the frame interval to 100 pixels.

**Related Commands**   :View<x>:YHeight

## Polar View Commands

When you select Polar in the `:Config:View<x>` command, use the commands in this section to control the Polar view.

For information on the Polar view, refer to the *User Manual*.

**:View<x>:AlphaBT (?)**

Sets or queries the  $\alpha$ /BT value.

**Syntax**    :View<x>:AlphaBT <value>  
              :View<x>:AlphaBT?

**Arguments**   <value>::=<NR2> ranges 0.0001 to 1.

**Examples**    :View1:AlphaBT 1  
              sets the  $\alpha$ /BT value to 1.

**:View<x>:AutoCarrier (?)**

Determines whether to search the carrier automatically for each frame.

**Syntax**    :View<x>:AutoCarrier { On | Off }  
              :View<x>:AutoCarrier?

**Arguments**   On searches the carrier automatically for each frame, and displays the frequency error in reference to the center frequency on screen at `Freq Error`.  
  
              Off sets the carrier frequency to the value set with the `:View<x>:Carrier` command.

**Examples**    :View1:AutoCarrier On  
              searches the carrier automatically and displays the frequency error.

**Related Commands**   :View<x>:Carrier

**:View<x>:Burst:BlockSize (?)**

Sets or queries the range for searching a burst signal in frames. The start frame is set with the `:View<x>:Z` command. If the number of frames after the start frame does not reach the specified number, the frames before the start frame are also used. See Figure 2–4.

**Syntax**     `:View<x>:Burst:BlockSize <value>`  
                  `:View<x>:Burst:BlockSize?`

**Arguments**     `<value>::=<NR1>` ranges 1 to 20 frames.

**Examples**       `:View1:Burst:BlockSize 4`  
                  sets the range for the burst search to 4 frames.

**Related Commands**     `:View<x>:Burst:NumberFrames`, `:View<x>:Burst:Offset`,  
                  `:View<x>:Burst:Search`, `:View<x>:Burst:Threshold`, `:View<x>:Z`

**:View<x>:Burst:NumberFrames (?)**

Sets or queries the range for acquiring burst data. See Figure 2–4.

**Syntax**       `:View<x>:Burst:NumberFrames <value>`  
                  `:View<x>:Burst:NumberFrames?`

**Arguments**     `<value>::=<NR1>` is 1 or 2 frames.

**Examples**       `:View1:Burst:NumberFrames 2`  
                  sets the range for burst data acquisition to 2 frames.

**Related Commands**     `:View<x>:Burst:BlockSize`, `:View<x>:Burst:Offset`,  
                  `:View<x>:Burst:Search`, `:View<x>:Burst:Threshold`, `:View<x>:Z`

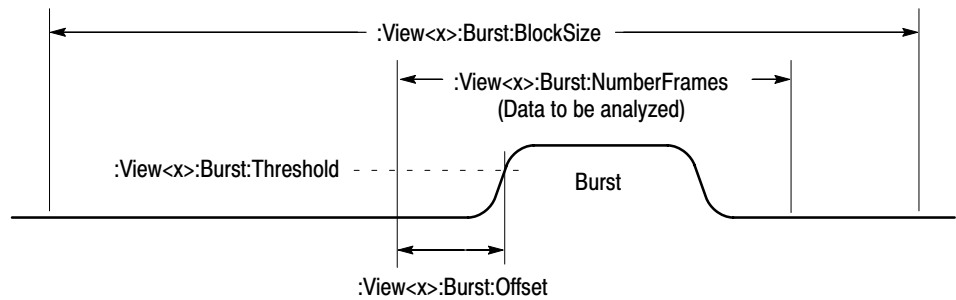

**Figure 2-4: Settings for burst analysis**

## **:View<x>:Burst:Offset (?)**

Sets or queries the start point for acquiring burst data relative to the rising edge of the burst signal. See Figure 2-4.

**Syntax**    :View<x>:Burst:Offset <value>

:View<x>:Burst:Offset?

**Arguments**    <value> ::= <NR1> ranges -1024 to +1024 points. The minus values represent the data points before the rising edge.

**Examples**    :View1:Burst:Offset -10  
specifies that the analyzer acquires burst data from 10 points before the rising edge.

**Related Commands**    :View<x>:Burst:BlockSize, :View<x>:Burst:NumberFrames,  
:View<x>:Burst:Search, :View<x>:Burst:Threshold, :View<x>:Z



**:View<x>:Burst:Search (?)**

Determines whether to search a burst signal.

**Syntax**    :View<x>:Burst:Search { On | Off }  
               :View<x>:Burst:Search?

**Arguments**    On searches a burst for analyzing.  
                   Off analyzes the frame specified with the :View<x>:Z command.

**Examples**     :View1:Burst:Search On  
                   searches a burst for analyzing.

**Related Commands**    :View<x>:Burst:BlockSize, :View<x>:Burst:NumberFrames,  
                           :View<x>:Burst:Offset, :View<x>:Burst:Threshold, :View<x>:Z

**:View<x>:Burst:Threshold (?)**

Sets or queries the threshold for determining the rising edge of a burst signal.  
 See Figure 2–4.

**Syntax**        :View<x>:Burst:Threshold <value>  
                   :View<x>:Burst:Threshold?

**Arguments**    <value>::=<NR1> ranges –100 to +10 dB. The value is the relative level from  
 the maximum within the burst search range.

**Examples**     :View1:Burst:Threshold –20  
                   sets the threshold for determining the rising edge of a burst signal to –20 dB.

**Related Commands**    :View<x>:Burst:BlockSize, :View<x>:Burst:NumberFrames,  
                           :View<x>:Burst:Offset, :View<x>:Burst:Search, :View<x>:Z

**:View<x>:Carrier (?)**

Sets or queries the carrier frequency.

**Syntax**    :View<x>:Carrier <value>  
              :View<x>:Carrier?

**Arguments**   <value>::=<NR3> ranges 0 Hz to 3 GHz.

**Examples**    :View1:Carrier 1.2G  
              sets the carrier frequency to 1.2 GHz.

**Related Commands**   :View<x>:AutoCarrier

**:View<x>:Display (?)**

Selects or queries the display data source.

**Syntax**    :View<x>:Display { Measurement | Reference }  
              :View<x>:Display?

**Arguments**   Measurement displays the measurement data.  
              Reference displays the reference data.

**Examples**    :View1:Display Measurement  
              displays the measurement data.

**Related Commands**   :View<x>:MeasDestination, :View<x>:RefDestination

**:View<x>:Format (?)**

Selects or queries the waveform display format.

**Syntax**    :View<x>:Format { Vector | Constellation }  
              :View<x>:Format?

**Arguments**    Vector specifies the Vector format. It displays symbol-to-symbol movements using vector.

                  Constellation specifies the Constellation format. It displays only symbols.

**Examples**     :View1:Format Vector  
                  selects the Vector display format.

**:View<x>:Marker:A? (Query Only)**

Queries the amplitude at the marker position.

**Syntax**     :View<x>:Marker:A?

**Returns**    <NR3>

**Examples**    :View1:Marker:A?  
                  might return 0.789.

**Related Commands**    :View<x>:Marker:P?

**:View<x>:Marker:DeltaT (?)**

Sets or queries the delta-marker position on the time axis.

**Syntax**     :View<x>:Marker:DeltaT <value>  
              :View<x>:Marker:DeltaT?

**Arguments**   <value>::=<NR3> ranges the minimum to the maximum value on the time axis.

**Examples**     :View1:Marker:DeltaT 5.4u  
                  positions the delta marker at 5.4  $\mu$ s.

**Related Commands**   :View<x>:Marker:T

**:View<x>:Marker:P? (Query Only)**

Queries the phase at the marker position.

**Syntax**     :View<x>:Marker:P?

**Returns**    <NR3>

**Examples**     :View1:Marker:P?  
                  might return 51.313, indicating that the marker is positioned at 51.313 degrees.

**Related Commands**   :View<x>:Marker:A?

**:View<x>:Marker:T (?)**

Sets or queries the marker position on the time axis.

**Syntax**     :View<x>:Marker:T <value>  
              :View<x>:Marker:T?

**Arguments**   <value>::=<NR3> ranges the minimum to the maximum value on the time axis.

**Examples** :View1:Marker:T 5.4u  
positions the marker at 5.4  $\mu$ s.

**Related Commands** :View<x>:Marker:DeltaT?

### **:View<x>:Marker:X? (Query Only)**

Queries the horizontal position of the marker.

**Syntax** :View<x>:Marker:X?

**Returns** <NR3>  
1 represents the full-scale.

**Examples** :View1:Marker:X?  
might return 0.345.

**Related Commands** :View<x>:Marker:Y?

### **:View<x>:Marker:Y? (Query Only)**

Queries the vertical position of the marker.

**Syntax** :View<x>:Marker:Y?

**Returns** <NR3>  
1 represents the full-scale.

**Examples** :View1:Marker:Y?  
might return 0.765.

**Related Commands** :View<x>:Marker:X?

## **:View<x>:MeasDestination (?)**

Selects or queries the register pair to store the measurement data.

**Syntax**     :View<x>:MeasDestination { None | D1D2 | D3D4 | D5D6 | D7D8 }  
              :View<x>:MeasDestination?

**Arguments**   None specifies no destination.  
              D1D2 to D7D8 specify a register pair to store the measurement data.

**Examples**     :View1:MeasDestination D1D2  
              specifies the D1 and D2 register pair for storing data.

**Related Commands**   :View<x>:RefDestination

## **:View<x>:MeasFilter (?)**

Selects or queries the filter to create the measurement data.

**Syntax**     :View<x>:MeasFilter { None | RootRaisedCosine }  
              :View<x>:MeasFilter?

**Arguments**   None selects no filter.  
              RootRaisedCosine selects the root raised-cosine filter.

**Examples**     :View1:MeasFilter RootRaisedCosine  
              selects the root raised-cosine filter to create the measurement data.

**Related Commands**   :View<x>:RefFilter

**:View<x>:Modulation (?)**

Selects or queries the modulation type.

**Syntax**    :View<x>:Modulation { PI4QPSK | BPSK | QPSK | PSK8 | QAM16 | QAM64 | GMSK }  
               :View<x>:Modulation?

**Arguments**    PI4QPSK selects  $1/4 \pi$  Shift QPSK (Quadrature Phase Shift Keying) modulation.  
                   BPSK selects BPSK (Binary Phase Shift Keying) modulation.  
                   QPSK selects QPSK (Quadrature Phase Shift Keying) modulation.  
                   PSK8 selects 8PSK (Phase Shift Keying) modulation.  
                   QAM16 selects 16QAM (Quadrature Amplitude Modulation).  
                   QAM64 selects 64QAM (Quadrature Amplitude Modulation).  
                   GMSK selects GMSK (Gaussian-filtered Minimum Shift Keying) modulation.

**Examples**    :View1:Modulation PI4QPSK  
                   selects the  $1/4 \pi$  Shift QPSK modulation.

**:View<x>:Position (?)**

Specifies or queries which frame in a block to be displayed.

**Syntax**    :View<x>:Position <value>  
               :View<x>:Position?

**Arguments**    <value>::=<NR2> ranges 0 to 100 %. It specifies the display frame position relative to the block size. 0 % specifies that the first frame in a block is displayed. 100 % represents the last frame.

**Examples**    :View1:Position 100  
                   displays the last frame in a block.

## **:View<x>:RefDestination (?)**

Selects or queries the register pair to store the reference data.

**Syntax**     :View<x>:RefDestination { None | D1D2 | D3D4 | D5D6 | D7D8 }  
              :View<x>:RefDestination?

**Arguments**   None specifies no destination.  
              D1D2 to D7D8 specify the register pair to store the reference data.

**Examples**     :View1:RefDestination D1D2  
              selects the D1 and D2 register pair to store the reference data.

**Related Commands**   :View<x>:MeasDestination

## **:View<x>:RefFilter (?)**

Selects or queries the filter to create the reference data.

**Syntax**     :View<x>:RefFilter { None | RaisedCosine | Gaussian }  
              :View<x>:RefFilter?

**Arguments**   None selects no filter.  
              RaisedCosine selects the raised cosine filter.  
              Gaussian selects the Gaussian filter.

**Examples**     :View1:RefFilter RaisedCosine  
              selects the raised cosine filter to create the reference data.

**Related Commands**   :View<x>:MeasFilter



**:View<x>:Result<y>? (Query Only)**

Queries the measurement result.

**Syntax** :View<x>:Result<y>?

**Returns** <NR3>

Result1 returns the carrier frequency error in reference to the center frequency.

Result2 returns the origin offset.

Result3 returns the full-scale in volts.

**Examples** :View1:Result1?  
might return 15.23, indicating that the carrier frequency error is 15.23 Hz.

**:View<x>:Source (?)**

Selects or queries the display data source for the specified view.

**Syntax** :View<x>:Source { None | Active | Zoom | <file\_name> }  
:View<x>:Source?

**Arguments** None specifies no source. The display area in the view will be emptied.

Active specifies the currently acquired data as the source.

Zoom specifies the zoomed data as the source.

<file\_name>::=<string> specifies the data file as the source. The file name must be “\*.IQ” (the IQ format).

**Examples** :View1:Source Active  
specifies the currently acquired data as the source.

**Related Commands** :Config:Mode

**:View<x>:Standard:CDPD (No Query Form)**

Configures the modulating system according to the CDPD (Cellular Digital Packet Data) standard.

**Syntax**     :View<x>:Standard:CDPD

**Arguments**   None

**Examples**     :View1:Standard:CDPD  
configures the modulating system according to the CDPD standard.

**:View<x>:Standard:GSM (No Query Form)**

Configures the modulating system according to the GSM (Global System for Mobile Communication) standard.

**Syntax**     :View<x>:Standard:GSM

**Arguments**   None

**Examples**     :View1:Standard:GSM  
configures the modulating system according to the GSM standard.

**:View<x>:Standard:NADC (No Query Form)**

Configures the modulating system according to the NADC (North American Digital Cellular) standard.

**Syntax**     :View<x>:Standard:NADC

**Arguments**   None

**Examples**     :View1:Standard:NADC  
configures the modulating system according to the NADC standard.

**:View<x>:Standard:PDC (No Query Form)**

Configures the modulating system according to the PDC (Personal Digital Cellular System) standard.

**Syntax** :View<x>:Standard:PDC

**Arguments** None

**Examples** :View1:Standard:PDC  
configures the modulating system according to the PDC standard.

**:View<x>:Standard:PHS (No Query Form)**

Configures the modulating system according to the PHS (Personal Handy Phone System) standard.

**Syntax** :View<x>:Standard:PHS

**Arguments** None

**Examples** :View1:Standard:PHS  
configures the modulating system according to the PHS standard.

**:View<x>:Standard:TETRA (No Query Form)**

Configures the modulating system according to the TETRA (Trans-European Trunked Radio) standard.

**Syntax** :View<x>:Standard:TETRA

**Arguments** None

**Examples** :View1:Standard:TETRA  
configures the modulating system according to the TETRA standard.

**:View<x>:SymbolRate (?)**

Sets or queries the symbol rate for the digital modulation.

**Syntax**    :View<x>:SymbolRate <value>  
              :View<x>:SymbolRate?

**Arguments** <value>::=<NR3> ranges 1/s to 30 M/s.

**Examples**    :View1:SymbolRate 8M  
              sets the symbol rate to 8 M/s.

**:View<x>:Version?**

Queries the version of the Polar View program.

**Syntax**    :View<x>:Version?

**Returns**    <NR2>

**Examples**    :View1:Version?  
              might return 1.1.

**:View<x>:Z (?)**

Specifies or queries the displayed frame number.

**Syntax**    :View<x>:Z <value>  
              :View<x>:Z?

**Arguments** <value>::=<NR1> ranges from 0 to the number of frames – 1.

**Examples**    :View1:Z 199  
              specifies that the frame 199 displays.

## Eye Diagram View Commands

When you select EyeDiagram in the `:Config:View<x>` command, use the commands in this section to control the Eye Diagram view.

For information on the eye diagram, refer to the *User Manual*.

**:View<x>:EyeLength (?)**

Sets or queries the number of symbols to be displayed, i.e. the horizontal scale.

**Syntax**     :View<x>:EyeLength <value>  
              :View<x>:EyeLength?

**Arguments**   <value>::=<NR1> ranges 1 to 16.  
              The default length is set to two symbols.

**Examples**     :View1:EyeLength 4  
              displays four symbols in the eye diagram.

**Related Commands**   :View<x>:Format

**:View<x>:Format (?)**

Selects or queries the parameter of the vertical axis. To specify the horizontal axis, use the :View<x>:EyeLength command.

**Syntax**     :View<x>:Format { I | Q | Trellis }  
              :View<x>:Format?

**Arguments**   I displays the eye diagram with the I data along the vertical axis.  
              Q displays the eye diagram with the Q data along the vertical axis.  
              Trellis displays the eye diagram with the phase along the vertical axis.

**Examples**     :View1:Format I  
              displays the eye diagram with the I data along the vertical axis.

**Related Commands**   :View<x>:EyeLength

**:View<x>:Marker:T (?)**

Sets or queries the marker position on the time axis.

**Syntax** :View<x>:Marker:T <value>

:View<x>:Marker:T?

**Arguments** <value>::=<NR3> ranges the minimum to the maximum value on the time axis.

**Examples** :View1:Marker:T 5.5u  
positions the marker at 5.5  $\mu$ s.

**Related Commands** :View<x>:Marker:Y?

**:View<x>:Marker:Y? (Query Only)**

Queries the vertical position of the marker.

**Syntax** :View<x>:Marker:Y?

**Returns** <NR3>

**Examples** :View1:Marker:Y?  
might return 0.000005, indicating that the marker is positioned at 5  $\mu$ s.

**Related Commands** :View<x>:Marker:T

## **:View<x>:Source (?)**

Selects or queries the data source for the eye diagram.

**Syntax**    :View<x>:Source { Measurement | Reference }  
:View<x>:Source?

**Arguments**    Measurement selects the measurement data as the view source. The data is stored in the register pair specified with the :View<x>:MeasDestination in the Polar View or the CDMA Polar View command group.

Reference selects the reference data as the data source. The data is stored in the register pair specified with the :View<x>:RefDestination in the Polar View or the CDMA Polar View command group.

**Examples**    :View1:Source Measurement  
selects the measurement data as the view source.

**Related Commands**    :View<x>:MeasDestination and :View<x>:RefDestination  
in the Polar View or the CDMA Polar View command group

## **:View<x>:Version?**

Queries the version of the Eye Diagram View program.

**Syntax**    :View<x>:Version?

**Returns**    <NR2>

**Examples**    :View1:Version?  
might return 1.1.



## Symbol Table View Commands

When you select `SymbolTable` in the `:Config:View<x>` command, use the commands in this section to control the Symbol Table view.

For information on the symbol table, refer to the *User Manual*.

## **:View<x>:CopyTo (No Query Form)**

Stores the display data to the Windows clipboard.

**Syntax**     :View<x>:CopyTo Clipboard

**Arguments**   Clipboard stores the display data to the Windows clipboard in the ASCII text format. You can use the data in your application.

**Examples**     :View1:CopyTo Clipboard  
stores the display data to the clipboard.

## **:View<x>:Marker:Data? (Query Only)**

Queries the value on the marker position.

**Syntax**     :View<x>:Marker:Data?

**Returns**     <NR1>

**Examples**     :View1:Marker:Data?  
might return 3.

**Related Commands**   :View<x>:Marker:Symbol?, :View<x>:Marker:T?, :View<x>:Symbol

## **:View<x>:Marker:Symbol? (Query Only)**

Queries the marker position on the symbol table. This command is the same as the `:View<x>:Symbol?` command, and exists for compatibility.

**Syntax**     `:View<x>:Marker:Symbol?`

**Returns**    `<NR1>`

**Examples**    `:View1:Marker:Symbol?`  
might return 110, indicating that the marker is positioned at the symbol number 110.

**Related Commands**   `:View<x>:Marker:Data?`, `:View<x>:Marker:T?`, `:View<x>:Symbol?`

## **:View<x>:Marker:T (?)**

Sets or queries the marker position on the time axis.

**Syntax**     `:View<x>:Marker:T <value>`

`:View<x>:Marker:T?`

**Arguments**   `<value>::=<NR3>` ranges the minimum to the maximum value on the time axis.

**Examples**    `:View1:Marker:T 5u`  
positions the marker at 5  $\mu$ s.

**Related Commands**   `:View<x>:Marker:Data?`, `:View<x>:Marker:Symbol?`, `:View<x>:Symbol`

**:View<x>:Radix (?)**

Selects or queries the display data format.

**Syntax**     :View<x>:Radix { Hex | Oct | Bin }  
              :View<x>:Radix?

**Arguments**   Hex selects the hexadecimal format.  
              Oct selects the octal format.  
              Bin selects the binary format.

**Examples**     :View1:Radix Hex  
              selects the hexadecimal format to display data.

**Related Commands**   :View<x>:Marker:Data?

**:View<x>:Rotate (?)**

Sets or queries the numeric value start position. It is unavailable for the  $1/4 \pi$  QPSK and GMSK modulating system.

**Syntax**     :View<x>:Rotate <value>  
              :View<x>:Rotate?

**Arguments**   <value>::=<NR1> ranges 0 to 3.

**Examples**     :View1:Rotate 3  
              sets the numeric value start position to 3.

**Related Commands**   :View<x>:Marker:Data?

**:View<x>:Source (?)**

Selects or queries the data source for the symbol table.

**Syntax** :View<x>:Source { Measurement | Reference }  
:View<x>:Source?

**Arguments** Measurement selects the measurement data as the view source. The data is stored in the register pair specified with the :View<x>:MeasDestination in the Polar View or the CDMA Polar View command group.

Reference selects the reference data as the view source. The data is stored in the register pair specified with the :View<x>:RefDestination in the Polar View or the CDMA Polar View command group.

**Examples** :View1:Source Measurement  
selects the measurement data as the view source.

**Related Commands** :View<x>:MeasDestination and :View<x>:RefDestination  
in the Polar View or the CDMA Polar View command group

**:View<x>:Symbol (?)**

Sets or queries the symbol location where the marker is placed.

**Syntax** :View<x>:Symbol <value>  
:View<x>:Symbol?

**Arguments** <value>::=<NR1> ranges from 0 to the number of symbols – 1.

**Examples** :View1:Symbol 10  
places the marker on the symbol number 10.

**Related Commands** :View<x>:Marker:Symbol?, :View<x>:Marker:T

## **:View<x>:Version? (Query Only)**

Queries the version of the Symbol Table View program.

**Syntax**     :View<x>:Version?

**Returns**    <NR2>

**Examples**    :View1:Version?  
                might return 1.1.

## EVM View Commands

When you select EVM in the `:Config:View<x>` command, use the commands in this section to control the EVM (Error Vector Magnitude) view.

For information on the EVM view, refer to the *User Manual*.

## :View<x>:CopyTo (No Query Form)

Stores the display data to a file or data register. This command is effective only for the data acquired in the Vector mode.

**Syntax**     :View<x>:CopyTo { Clipboard | D1 | D2 | D3 | D4 | D5 | D6 | D7 | D8 | <file\_name> }

**Arguments**   Clipboard stores the display data to the Windows clipboard in the ASCII text format. You can use the data in your application.

D1 to D8 select the data register 1 to 8, respectively.

<file\_name>::=<string> is “\*.TXT” (ASCII text file). The extension is set to “.TXT” automatically.

**Examples**     :View1:CopyTo Clipboard  
stores the display data to the clipboard.

## :View<x>:Format (?)

Selects or queries the waveform display format.

**Syntax**     :View<x>:Format { EVM | MagError | PhaseError }  
:View<x>:Format?

**Arguments**   Defines the parameters associated with the horizontal and vertical axes as follows:

Argument	Display	Horizontal axis	Vertical axis
EVM	Error vector magnitude	Time	Percentage of EVM
MagError	Amplitude error	Time	Percentage of amplitude error
PhaseError	Phase error	Time	Percentage of phase error

**Examples**     :View1:Format EVM  
shows the waveform with time along the horizontal axis and percentage of EVM along the vertical axis.



**:View<x>:Marker:DeltaMarker (?)**

Turns the delta marker on or off.

**Syntax** :View<x>:Marker:DeltaMarker { On | Off }  
:View<x>:Marker:DeltaMarker?

**Arguments** On turns the delta marker on.  
Off turns the delta marker off.

**Examples** :View1:Marker:DeltaMarker On  
turns the delta marker on.

**Related Commands** :View<x>:Marker:DeltaX, :View<x>:Marker:DeltaY?,  
:View<x>:Marker:ResetDelta

**:View<x>:Marker:DeltaX (?)**

Sets or queries the horizontal position of the delta marker.

**Syntax** :View<x>:Marker:DeltaX <value>  
:View<x>:Marker:DeltaX?

**Arguments** <value>::=<NR3> ranges from the minimum (left) edge to the maximum (right) edge of the the horizontal axis.

**Examples** :View1:Marker:DeltaX 5u  
positions the delta marker at 5  $\mu$ s.

**Related Commands** :View<x>:Marker:DeltaY?

**:View<x>:Marker:DeltaY? (Query Only)**

Queries the vertical position of the delta marker.

**Syntax** :View<x>:Marker:DeltaY?

**Returns** <NR3>

**Examples** :View1:Marker:DeltaY?  
might return 1.78.

**Related Commands** :View<x>:Marker:DeltaX

**:View<x>:Marker:ResetDelta (No Query Form)**

Moves the delta marker to the main marker position.

**Syntax** :View<x>:Marker:ResetDelta

**Arguments** None

**Examples** :View1:Marker:ResetDelta

**Related Commands** :View<x>:Marker:DeltaMarker

**:View<x>:Marker:SearchMax (No Query Form)**

Positions the marker on the highest signal on screen.

**Syntax** :View<x>:Marker:SearchMax

**Arguments** None

**Examples** :View1:Marker:SearchMax  
positions the marker on the highest signal on screen.

**Related Commands** :View<x>:Marker:SearchMin

**:View<x>:Marker:SearchMin (No Query Form)**

Positions the marker on the lowest signal on screen.

**Syntax** :View<x>:Marker:SearchMin

**Arguments** None

**Examples** :View1:Marker:SearchMin  
positions the marker on the lowest signal on screen.

**Related Commands** :View<x>:Marker:SearchMax

**:View<x>:Marker:X (?)**

Sets or queries the horizontal position of the marker.

**Syntax** :View<x>:Marker:X <value>

:View<x>:Marker:X?

**Arguments** <value>::=<NR3> ranges from the minimum (left) edge to the maximum (right) edge of the the horizontal axis.

**Examples** :View1:Marker:X 5u  
positions the marker at 5  $\mu$ s.

**Related Commands** :View<x>:Marker:Y?

**:View<x>:Marker:Y? (Query Only)**

Queries the vertical position of the marker.

**Syntax** :View<x>:Marker:Y?

**Returns** <NR3> in percent (%).

**Examples** :View1:Marker:Y?  
might return 1.543, indicating that the marker is positioned at 1.543 %.

**Related Commands** :View<x>:Marker:X

**:View<x>:MaskArea (?)**

Sets or queries the area on display to exclude from calculating EVM.  
See Figure 2–5.

**Syntax** :View<x>:MaskArea <value>

:View<x>:MaskArea?

**Arguments** <value>::=<NR3> ranges from 0 to 50 %. Both right and left ends are excluded.  
0 % excludes no area. 50 % excludes the whole area.

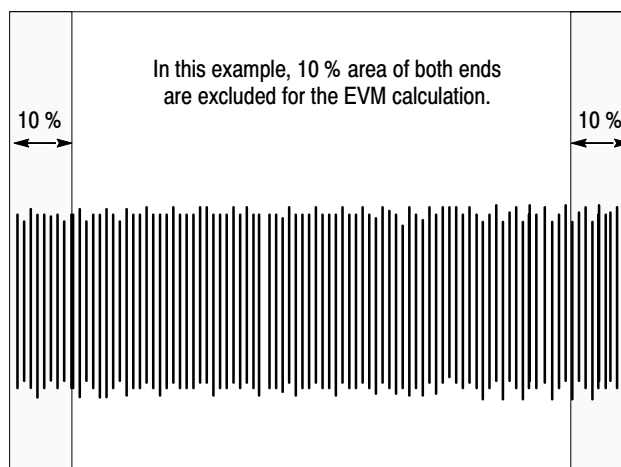

**Figure 2-5: Setting the mask for the EVM calculation**

**Examples**    :View1:MaskArea 10  
excludes 10 % area from both right and left edges for the EVM calculation.

## **:View<x>:Result<y>? (Query Only)**

Queries the measurement results.

**Syntax**    :View<x>:Result<y>?

**Returns**    <NR3>

Result1 returns the EVM in percent rms.

Result2 returns the magnitude error in percent rms.

Result3 returns the phase error in degree.

Result4 returns the  $\rho$  (Rho).

**Examples**    :View1:Result1?  
might return 2.913, indicating that the EVM is 2.913 % rms.

## **:View<x>:Scale:AutoScale (No Query Form)**

Adjusts the scaling of the vertical axis automatically to best display the data.

**Syntax**    :View<x>:Scale:AutoScale

**Arguments**    None

**Examples**    :View1:Scale:AutoScale  
adjusts the scaling of the vertical axis automatically.

**Related Commands**    :View<x>:Scale:XScale, :View<x>:Scale:YScale

**:View<x>:Scale:XScale (?)**

Sets or queries the horizontal axis full-scale to display a portion of the data.

**Syntax**     :View<x>:Scale:XScale <value>  
              :View<x>:Scale:XScale?

**Arguments**   <value>::=<NR3> ranges full-scale/256 to full-scale of the acquired data.

**Examples**     :View1:Scale:XScale 640u  
                  sets the horizontal axis full-scale to 640  $\mu$ s.

**Related Commands**   :View<x>:Scale:XStart, :View<x>:Scale:YScale

**:View<x>:Scale:XStart (?)**

Sets or queries the value represented by the minimum (left) edge of the horizontal axis.

**Syntax**     :View<x>:Scale:XStart <value>  
              :View<x>:Scale:XStart?

**Arguments**   <value>::=<NR3> ranges from the minimum to the maximum value on the horizontal axis of the acquired data.

**Examples**     :View1:Scale:XStart 160u  
                  sets the value represented by the left edge of the horizontal axis to 160  $\mu$ s.

**Related Commands**   :View<x>:Scale:XScale

**:View<x>:Scale:YScale (?)**

Sets or queries the vertical axis full-scale to display a portion of the data.

**Syntax** :View<x>:Scale:YScale <value>  
:View<x>:Scale:YScale?

**Arguments** <value>::=<NR3> ranges full-scale/100 to full-scale of the acquired data.

**Examples** :View1:Scale:YScale 50  
sets the vertical axis full-scale to 50 %.

**Related Commands** :View<x>:Scale:XScale, :View<x>:Scale:YStart

**:View<x>:Scale:YStart (?)**

Sets or queries the value represented by the minimum (bottom) edge of the vertical axis.

**Syntax** :View<x>:Scale:YStart <value>  
:View<x>:Scale:YStart?

**Arguments** <value>::=<NR3> ranges from the minimum to the maximum value on the vertical axis of the acquired data.

**Examples** :View1:Scale:YStart 0  
sets the value represented by the bottom edge of the vertical axis to 0 %.

**Related Commands** :View<x>:Scale:YScale

**:View<x>:Symbol (?)**

Sets or queries the symbol position to place the marker.

**Syntax**    :View<x>:Symbol <value>  
              :View<x>:Symbol?

**Arguments**   <value>::=<NR1> ranges from 0 to the number of symbols – 1.

**Examples**    :View1:Symbol 10  
              places the marker on the symbol number 10.

**Related Commands**   :View<x>:Marker:X, :View<x>:Marker:Y?

**:View<x>:Version? (Query Only)**

Queries the version of the EVM View program.

**Syntax**    :View<x>:Version?

**Returns**   <NR2>

**Examples**   :View1:Version?  
              might return 1.1.



## CDMA Waveform View Commands

When you select CDMAWaveform in the :Config:View<x> command, use the commands in this section to control the CDMA Waveform view.

## **:View<x>:Average:Times (?)**

Sets or queries the number of frames that make up an averaged waveform.

**Syntax**    :View<x>:Average:Times <value>  
              :View<x>:Average:Times?

**Arguments**   <value>::=<NR1> is the number of frames for averaging, from 1 to 1000.

**Examples**    :View1:Average:Times 1000  
              specifies that an averaged waveform will show the result of combining 1000 frames.

**Related Commands**   :View<x>:Average:Type

## **:View<x>:Average:Type (?)**

Selects or queries the average type. You can also select the peak hold mode. For more information about averaging, refer to the *User Manual*.

**Syntax**    :View<x>:Average:Type { RMSExpo | RMS | PeakHold }  
              :View<x>:Average:Type?

**Arguments**   RMSExpo averages with the RMS (root mean squared) exponential. This mode weights older acquisition data so that they have a progressively smaller effect on the average.

RMS averages with the RMS (root mean squared).

PeakHold holds the peak value for each data point.

**Examples**    :View1:Average:Type RMSExpo  
              averages waveform with the exponential RMS.

**Related Commands**   :View<x>:Average:Time

## **:View<x>:CDMA:Channel (?)**

Selects or queries the channel.

**Syntax**     :View<x>:CDMA:Channel <value>  
                   :View<x>:CDMA:Channel?

**Arguments**   <value>::=<NR1> specifies the channel number.

For the IS-95 standard, the range is 1 to 777. Channel 1 and 777 correspond to 825.03 and 848.31 MHz, respectively. The frequency difference between two adjacent channels is 0.03 MHz.

For the T-53 standard, the range is 1 to 1199. Channel 1 and 1199 correspond to 915.0125 and 888.9875 MHz, respectively. The frequency difference between two adjacent channels is 0.0125 MHz.

**Examples**     :View1:CDMA:Channel 777  
                   sets the channel number to 777.

**Related Commands**   :Setup:CDMA:Channel

## :View<x>:Compression (?)

Selects or queries the display data compression method. It specifies how to take or discard each acquired data point for a corresponding pixel on the screen because the number of horizontal pixels is usually less than that of data points.

**Syntax**     :View<x>:Compression { Sample | MinMax | Max | Min }  
                   :View<x>:Compression?

**Arguments**   Sample takes the acquired data points at regular intervals to obtain a waveform display.

MinMax takes the minimum and the maximum data points for a corresponding pixel. The minimum and the maximum data points are displayed with a vertical bar on the screen.

Max takes the maximum data point for a corresponding pixel.

Min takes the minimum data point for a corresponding pixel.

**Examples**     :View1:Compression Sample  
                   takes the acquired data points at regular intervals to obtain a waveform display.

## **:View<x>:CopyFrom (No Query Form)**

Loads the display data from the text file.

**Syntax**     :View<x>:CopyFrom <file\_name>

**Arguments**   <file\_name>::=<string> is “\*.TXT” (ASCII text file).  
The file is the one to which the display data has been stored with the  
:View<x>:CopyTo command.

**Examples**     :View1:CopyFrom "SAMPLE1.TXT"  
loads the display data from the file SAMPLE1.TXT.

**Related Commands**   :View<x>:CopyTo

## **:View<x>:CopyTo (No Query Form)**

Stores the display data to a file or data register. This command is effective only for the data acquired in the Vector mode.

**Syntax**     :View<x>:CopyTo { Clipboard | D1 | D2 | D3 | D4 | D5 | D6 | D7 | D8 | <file\_name> }

**Arguments**   Clipboard copies the display data to the Windows clipboard in the ASCII text format. You can use the data in your application.

D1 to D8 are the data register 1 to 8, respectively.

<file\_name>::=<string> is “\*.TXT” (ASCII text file). The extension is set to “.TXT” automatically.

**Examples**     :View1:CopyTo Clipboard  
stores the display data to the clipboard.

**Related Commands**   :View<x>:CopyFrom

## **:View<x>:Format (?)**

Sets or queries the waveform display format.

**Syntax** :View<x>:Format { FreqAmpl | FreqPhase | FreqI | FreqQ | TimeAmpl  
| TimePhase | TimeI | TimeQ }  
:View<x>:Format?

**Arguments** Defines the parameters associated with the horizontal and vertical axes as follows:

Argument	Horizontal axis	Vertical axis
FreqAmpl	Frequency (span)	Amplitude
FreqPhase	Frequency (span)	Phase
FreqI	Frequency (span)	I (In-Phase)
FreqQ	Frequency (span)	Q (Quadrature-Phase)
TimeAmpl	Time	Amplitude
TimePhase	Time	Phase
TimeI	Time	I (In-Phase)
TimeQ	Time	Q (Quadrature-phase)

**Examples** :View1:Format FreqAmpl  
shows the waveform with frequency along the horizontal axis and amplitude along the vertical axis.

## :View<x>:Marker:DeltaMarker (?)

Turns the delta marker on or off.

**Syntax** :View<x>:Marker:DeltaMarker { On | Off }  
:View<x>:Marker:DeltaMarker?

**Arguments** On turns the delta marker on.  
Off turns the delta marker off.

**Examples** :View1:Marker:DeltaMarker On  
turns the delta marker on.

**Related Commands** :View<x>:Marker:DeltaX, :View<x>:Marker:DeltaY?,  
:View<x>:Marker:ResetDelta

**:View<x>:Marker:DeltaX (?)**

Sets or queries the horizontal position of the delta marker.

**Syntax**     :View<x>:Marker:DeltaX <value>  
              :View<x>:Marker:DeltaX?

**Arguments**   <value>::=<NR3> ranges from the minimum (left) edge to the maximum (right) edge of the the horizontal axis.

**Examples**     :View1:Marker:DeltaX 1G  
                  positions the delta marker at 1 GHz.

**Related Commands**   :View<x>:Marker:DeltaY

**:View<x>:Marker:DeltaY? (Query Only)**

Queries the vertical position of the delta marker.

**Syntax**     :View<x>:Marker:DeltaY?

**Returns**    <NR3>

**Examples**     :View1:Marker:DeltaY?  
                  might return -100, indicating that the delta marker is positioned at -100 dB.

**Related Commands**   :View<x>:Marker:DeltaX

## **:View<x>:Marker:Peak (No Query Form)**

Moves the marker to the adjacent peak in the specified direction. Note that the adjacent peak is farther than the distance specified with the :View<x>:Marker:SearchSeparation command.

**Syntax** :View<x>:Marker:Peak { 1 | -1 }

**Arguments** 1 moves the marker to the adjacent peak on the left of the marker.  
-1 moves the marker to the adjacent peak on the right of the marker.

**Examples** :View1:Marker:Peak -1  
moves the marker to the adjacent peak on the right of the marker.

**Related Commands** :View<x>:Marker:SearchMax, :View<x>:Marker:SearchMin,  
:View<x>:Marker:SearchSeparation

## **:View<x>:Marker:ResetDelta (No Query Form)**

Moves the delta marker to the main marker position.

**Syntax** :View<x>:Marker:ResetDelta

**Arguments** None

**Examples** :View1:Marker:ResetDelta

**Related Commands** :View<x>:Marker:DeltaMarker

**:View<x>:Marker:SearchMax (No Query Form)**

Positions the marker on the highest signal on screen.

**Syntax** :View<x>:Marker:SearchMax

**Arguments** None

**Examples** :View1:Marker:SearchMax  
positions the marker on the highest signal on screen.

**Related Commands** :View<x>:Marker:SearchMin

**:View<x>:Marker:SearchMin (No Query Form)**

Positions the marker on the lowest signal on screen.

**Syntax** :View<x>:Marker:SearchMin

**Arguments** None

**Examples** :View1:Marker:SearchMin  
positions the marker on the lowest signal on screen.

**Related Commands** :View<x>:Marker:SearchMax

**:View<x>:Marker:SearchSeparation (?)**

Sets or queries the minimum horizontal distance to separate two peaks.

**Syntax** :View<x>:Marker:SearchSeparation <value>  
:View<x>:Marker:SearchSeparation?

**Arguments** <value>::=<NR2> specifies the minimum horizontal distance to separate two peaks. The range is 1 to 10 % relative to full-scale.



**Examples**     :View1:Marker:SearchSeparation 10  
sets the minimum horizontal distance for peak separation to 10 % relative to full-scale.

## **:View<x>:Marker:X (?)**

Sets or queries the horizontal position of the marker.

**Syntax**     :View<x>:Marker:X <value>  
              :View<x>:Marker:X?

**Arguments**   <value>::=<NR3> ranges from the minimum (left) edge to the maximum (right) edge of the the horizontal axis.

**Examples**     :View1:Marker:X 1.5G  
positions the marker at 1.5 GHz.

**Related Commands**   :View<x>:Marker:Y?

## **:View<x>:Marker:Y? (Query Only)**

Queries the vertical position of the marker.

**Syntax**     :View<x>:Marker:Y?

**Returns**     <NR3>

**Examples**     :View1:Marker:Y?  
might return -30, indicating that the marker is positioned at -30 dBm.

**Related Commands**   :View<x>:Marker:X

**:View<x>:Mask:RBW1M:Frequency (?)**

Sets or queries the frequency of the reference line at 1 MHz of resolution bandwidth (See Figure 2–6).

**Syntax**     :View<x>:Mask:RBW1M:Frequency <value>  
               :View<x>:Mask:RBW1M:Frequency?

**Arguments**   <value>::=<NR3> ranges 0 to 25 MHz.

**Examples**     :View1:Mask:RBW1M:Frequency 25M  
                   sets the frequency of the reference line to 25 MHz at 1 MHz of RBW.

**Related Commands**   :View<x>:Mask:RBW1M:Level

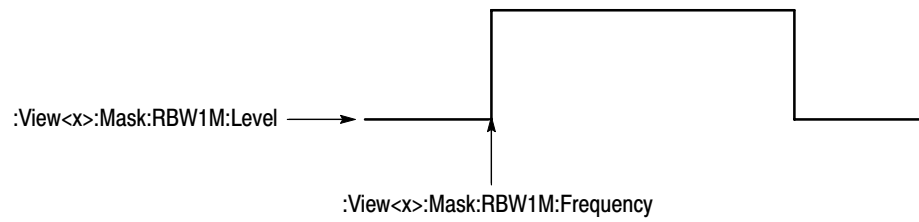

**Figure 2-6: Setting the reference line at 1 MHz of RBW**

**:View<x>:Mask:RBW1M:Level (?)**

Sets or queries the level of the reference line at 1 MHz of resolution bandwidth (See Figure 2–6).

**Syntax**     :View<x>:Mask:RBW1M:Level <value>  
               :View<x>:Mask:RBW1M:Level?

**Arguments**   <value>::=<NR3> ranges –100 dBm to 30dBm.

**Examples**     :View1:Mask:RBW1M:Level 30  
                   sets the level of the reference line to 30 dBm at 1 MHz of RBW.

**Related Commands**   :View<x>:Mask:RBW1M:Frequency

**:View<x>:Mask:RBW30k:Frequency1 (?)**

Sets or queries the frequency of the inner reference line at 30 kHz of resolution bandwidth (See Figure 2-7).

**Syntax** :View<x>:Mask:RBW30k:Frequency1 <value>  
:View<x>:Mask:RBW30k:Frequency1?

**Arguments** <value>::=<NR3> ranges 0 to 25 MHz.

**Examples** :View1:Mask:RBW30k:Frequency1 25M  
sets the frequency of the inner reference line to 25 MHz at 30 kHz of RBW.

**Related Commands** :View<x>:Mask:RBW30k:Frequency2

**:View<x>:Mask:RBW30k:Frequency2 (?)**

Sets or queries the frequency of the outer reference line at 30 kHz of resolution bandwidth (See Figure 2-7).

**Syntax** :View<x>:Mask:RBW30k:Frequency2 <value>  
:View<x>:Mask:RBW30k:Frequency2?

**Arguments** <value>::=<NR3> ranges 0 to 25 MHz.

**Examples** :View1:Mask:RBW30k:Frequency2 20M  
sets the frequency of the outer reference line to 20 MHz at 30 kHz of RBW.

**Related Commands** :View<x>:Mask:RBW30k:Frequency1

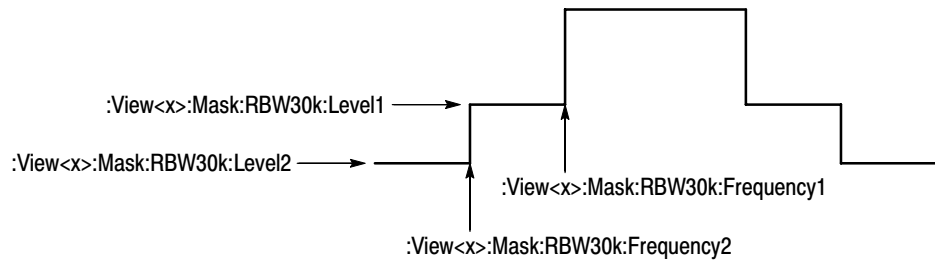

**Figure 2-7: Setting the reference line at 30 kHz of RBW**

### **:View<x>:Mask:RBW30k:Level1 (?)**

Sets or queries the level of the inner reference line at 30 kHz of resolution bandwidth (See Figure 2-7).

**Syntax**     :View<x>:Mask:RBW30k:Level1 <value>  
                   :View<x>:Mask:RBW30k:Level1?

**Arguments**   <value>::=<NR3> ranges -100 dB to 0 dB.

**Examples**     :View1:Mask:RBW30k:Level1 -42  
                   sets the level of the inner reference line to -42 dB at 30 kHz of RBW.

**Related Commands**   :View<x>:Mask:RBW30k:Level2

### **:View<x>:Mask:RBW30k:Level2 (?)**

Sets or queries the level of the outer reference line at 30 kHz of resolution bandwidth (See Figure 2-7).

**Syntax**     :View<x>:Mask:RBW30k:Level2 <value>  
                   :View<x>:Mask:RBW30k:Level2?

**Arguments**   <value>::=<NR3> ranges -100 dB to 0 dB.

**Examples**     :View1:Mask:RBW30k:Level2 -54  
                   sets the level of the outer reference line to -54 dB at 30 kHz of RBW.

**Related Commands**    :View<x>:Mask:RBW30k:Level1

## :View<x>:Measurement (?)

Selects or queries the measurement function. The measurement starts with the data acquisition. Query the results with the :View<x>:Result<y>? command.

**Syntax**    :View<x>:Measurement { Off | Power | Spurious }  
:View<x>:Measurement?

**Arguments**    Off turns the measurement off.  
Power selects the power measurement.  
Spurious selects the spurious measurement.

**Examples**    :View1:Measurement Power  
selects the power measurement.

**Related Commands**    :View<x>:Measurement:OBW, :View<x>:Result<y>?

## :View<x>:Measurement:OBW (?)

Sets or queries the occupied bandwidth.

**Syntax**    :View<x>:Measurement:OBW <value>  
:View<x>:Measurement:OBW?

**Arguments**    <value>::=<NR2> ranges 90 to 99.8 %.

**Examples**    :View1:Measurement:OBW 99.8  
sets the occupied bandwidth to 99.8 %.

**Related Commands**    :View<x>:Measurement

**:View<x>:Measurement:Separation (?)**

Sets or queries the frequency resolution for spurious search to distinguish two adjacent peaks. The resolution is represented by the ratio (%) to the span.

**Syntax**     :View<x>:Measurement:Separation <value>  
              :View<x>:Measurement:Separation?

**Arguments**   <value>::=<NR2> ranges 0 to 100 %. 100 % means that the resolution is equal to the span.

**Examples**     :View1:Measurement:Separation 100  
                  sets the spurious resolution to 100 % (= span).

**Related Commands**   :View<x>:Measurement, :View<x>:Measurement:SpuriousSearch

**:View<x>:Measurement:SortedBy (?)**

Sets or queries the sort key for the spurious signals.

**Syntax**     :View<x>:Measurement:SortedBy { Level | Frequency }  
              :View<x>:Measurement:SortedBy?

**Arguments**   Level specifies that the spurious signals are sorted by level.  
              Frequency specifies that the spurious signals are sorted by frequency.

**Examples**     :View1:Measurement:SortedBy Level  
                  specifies that the spurious signals are sorted by level.

**Related Commands**   :View<x>:Measurement, :View<x>:Measurement:SpuriousSearch

## **:View<x>:Measurement:SpuriousSearch (?)**

Determines whether or not to search spurious for each frame.

**Syntax**     :View<x>:Measurement:SpuriousSearch { On | Off }  
              :View<x>:Measurement:SpuriousSearch?

**Arguments**   On turns the spurious search on.  
              Off turns the spurious search off.

**Examples**     :View1:Measurement:SpuriousSearch On  
              turns the spurious search on.

**Related Commands**   :View<x>:Measurement:Threshold

## **:View<x>:Measurement:Threshold (?)**

Sets or queries the threshold level to detect spurious.

**Syntax**     :View<x>:Measurement:Threshold <value>  
              :View<x>:Measurement:Threshold?

**Arguments**   <value>::=<NR1> ranges –150 to 30 dB.

**Examples**     :View1:Measurement:Threshold 30  
              sets the threshold level to 30 dB for the spurious search.

**Related Commands**   :View<x>:Measurement:SpuriousSearch

**:View<x>:Position (?)**

Specifies or queries which frame in a block to be displayed.

**Syntax**    :View<x>:Position <value>  
              :View<x>:Position?

**Arguments**   <value>::=<NR2> ranges 0 to 100 %. It specifies the display frame position relative to the block size. 0 % specifies that the first frame in a block is displayed. 100 % represents the last frame.

**Examples**    :View1:Position 100  
              displays the last frame in acquiring waveform.

**:View<x>:RBW (?)**

Sets or queries the resolution bandwidth.

**Syntax**    :View<x>:RBW { 1M | 30k | Off }  
              :View<x>:RBW?

**Arguments**   1M sets the resolution bandwidth to 1 MHz.  
              30k sets the resolution bandwidth to 30 kHz.  
              Off displays the raw data of each bin.

**Examples**    :View1:RBW 1M  
              sets the resolution bandwidth to 1 MHz.



**:View<x>:Result<y>? (Query Only)**

Queries the measurement results. Select the measurement function with the :View<x>:Measurement command.

**Syntax** :View<x>:Result<y>?

**Returns** <NR3>

<y>=1 returns the power.

<y>=2 returns the occupied bandwidth.

<y>=3, 6, 9, 12, 15, 18, 21, or 24 returns the result of spurious test; Pass or Fail. Each number corresponds to each of eight spurious signals. "Pass" indicates that the waveform is within the specified limits. "Fail" indicates that the waveform exceeds the limits.

<y>=4, 7, 10, 13, 16, 19, 22, or 25 returns each spurious level of eight spurious signals.

<y>=5, 8, 11, 14, 17, 20, 23, or 26 returns each spurious frequency of eight spurious signals.

**Examples** :View1:Result5?

might return 825000000, indicating that the first spurious frequency is 825 MHz.

**Related Commands** :View<x>:Measurement

**:View<x>:Scale:AutoScale (No Query Form)**

Adjusts the scaling of the vertical axis automatically to best display the data. When the parameter is level or phase, this command sets the vertical axis to full-scale.

**Syntax**       :View<x>:Scale:AutoScale

**Arguments**    None

**Examples**       :View1:Scale:AutoScale  
adjusts the scaling of the vertical axis automatically.

**Related Commands**   :View<x>:Format, :View<x>:Scale:XScale, :View<x>:Scale:YScale

**:View<x>:Scale:HoldYScale (?)**

Determines whether to hold or reset the vertical scale when you change the input source.

**Syntax**       :View<x>:Scale:HoldYScale { On | Off }  
:View<x>:Scale:HoldYScale?

**Arguments**    On holds the vertical scale setting when you change the input source.  
Off resets the vertical scale to full-scale.

**Examples**       :View1:Scale:HoldYScale On  
holds the vertical scale setting when you change the input source.

**Related Commands**   :View<x>:Scale:YScale, :View<x>:Scale:YStart, :View<x>:Source

**:View<x>:Scale:XScale (?)**

Sets or queries the horizontal axis full-scale to display a portion of the data.

**Syntax**    :View<x>:Scale:XScale <value>  
              :View<x>:Scale:XScale?

**Arguments**   <value>::=<NR3> ranges full-scale/256 to full-scale of the acquired data.

**Examples**    :View1:Scale:XScale 2.5M  
              sets the horizontal axis full-scale to 2.5 MHz.

**Related Commands**   :View<x>:Scale:XStart, :View<x>:Scale:YScale

**:View<x>:Scale:XStart (?)**

Sets or queries the value represented by the minimum (left) edge of the horizontal axis.

**Syntax**    :View<x>:Scale:XStart <value>  
              :View<x>:Scale:XStart?

**Arguments**   <value>::=<NR3> ranges from the minimum to the maximum value on the horizontal axis of the acquired data.

**Examples**    :View1:Scale:XStart 800M  
              sets the value represented by the left edge of the horizontal axis to 800 MHz.

**Related Commands**   :View<x>:Scale:XScale

**:View<x>:Scale:YScale (?)**

Sets or queries the vertical axis full-scale to display a portion of the data.

**Syntax**     :View<x>:Scale:YScale <value>  
              :View<x>:Scale:YScale?

**Arguments**   <value>::=<NR3> ranges full-scale/100 to full-scale of the acquired data.

**Examples**     :View1:Scale:YScale 20  
                  sets the vertical axis full-scale to 20 dB.

**Related Commands**   :View<x>:Scale:XScale, :View<x>:Scale:YStart

**:View<x>:Scale:YStart (?)**

Sets or queries the value represented by the minimum (bottom) edge of the vertical axis.

**Syntax**     :View<x>:Scale:YStart <value>  
              :View<x>:Scale:YStart?

**Arguments**   <value>::=<NR3> ranges from the reference level – 200 dB to the reference level + 100 dB.

**Examples**     :View1:Scale:YStart -120  
                  sets the value represented by the bottom edge of the vertical axis to –120 dB.

**Related Commands**   :View<x>:Scale:YScale

**:View<x>:Source (?)**

Selects or queries the display data source for the specified view.

**Syntax**    :View<x>:Source { None | Active | Average | Zoom | D1D2 |  
D3D4 | D5D6 | D7D8 | D1 | D2 | D3 | D4 | D5 | D6 | D7 | D8 |  
<file\_name> }

:View<x>:Source?

**Arguments**    None specifies no source. The display area in the view will be emptied.

Active specifies the currently acquired data as the source.

Average specifies the averaged data as the source. When you select this item, you have to set the average type and the number of averages using the :View<x>:Average:Type and the :View<x>:Average:Times commands, respectively.

Zoom specifies the zoomed data as the source.

D1D2 to D7D8 specify the register pair D1D2 to D7D8 as the source, respectively.

D1 to D8 specify the data register D1 to D8 as the source, respectively.

<file\_name>::=<string> specifies the file as the source. The file name must be “\*.IQ” (the IQ format) or “\*.AP” (the AP format).

**Examples**    :View1:Source Active  
specifies the currently acquired data as the view source.

**Related Commands**    :Config:Mode, :View<x>:Average:Times, :View<x>:Average:Type

**:View<x>:Version? (Query Only)**

Queries the version of the CDMA Waveform View program.

**Syntax** :View<x>:Version?

**Returns** <NR2>

**Examples** :View1:Version?  
might return 1.1.

**:View<x>:Z (?)**

Specifies or queries the displayed frame number.

**Syntax** :View<x>:Z <value>

:View<x>:Z?

**Arguments** <value>::=<NR1> ranges from 0 to the number of frames – 1.

**Examples** :View1:Z 199  
specifies that the frame 199 displays.

## CDMA Polar View Commands

When you select `CDMAPolar` in the `:Config:View<x>` command, use the commands in this section to control the CDMA Polar view.

For information on the Polar view, refer to the *User Manual*.

**:View<x>:AlphaBT (?)**

Sets or queries the  $\alpha$ /BT value.

**Syntax**    :View<x>:AlphaBT <value>  
              :View<x>:AlphaBT?

**Arguments**   <value>::=<NR2> ranges 0.0001 to 1.

**Examples**    :View1:AlphaBT 1  
              sets the  $\alpha$ /BT value to 1.

**:View<x>:AutoCarrier (?)**

Determines whether to search the carrier automatically for each frame.

**Syntax**    :View<x>:AutoCarrier { On | Off }  
              :View<x>:AutoCarrier?

**Arguments**   On searches the carrier automatically for each frame, and displays the frequency error in reference to the center frequency on screen at `Freq Error`.  
  
              Off sets the carrier frequency to the value set with the `:View<x>:Carrier` command.

**Examples**    :View1:AutoCarrier On  
              searches the carrier automatically and displays the frequency error.

**Related Commands**   :View<x>:Carrier



**:View<x>:Burst:BlockSize (?)**

Sets or queries the range for searching a burst signal in frames. The start frame is set with the :View<x>:Z command. If the number of frames after the start frame does not reach the specified number, the frames before the start frame are also used. See Figure 2–8.

**Syntax** :View<x>:Burst:BlockSize <value>  
:View<x>:Burst:BlockSize?

**Arguments** <value>::=<NR1> ranges 1 to 20 frames.

**Examples** :View1:Burst:BlockSize 4  
sets the range for the burst search to 4 frames.

**Related Commands** :View<x>:Burst:NumberFrames, :View<x>:Burst:Offset,  
:View<x>:Burst:Search, :View<x>:Burst:Threshold, :View<x>:Z

**:View<x>:Burst:NumberFrames (?)**

Sets or queries the range for acquiring burst data. See Figure 2–8.

**Syntax** :View<x>:Burst:NumberFrames <value>  
:View<x>:Burst:NumberFrames?

**Arguments** <value>::=<NR1> is 1 or 2 frames.

**Examples** :View1:Burst:NumberFrames 2  
sets the range for burst data acquisition to 2 frames.

**Related Commands** :View<x>:Burst:BlockSize, :View<x>:Burst:Offset,  
:View<x>:Burst:Search, :View<x>:Burst:Threshold, :View<x>:Z

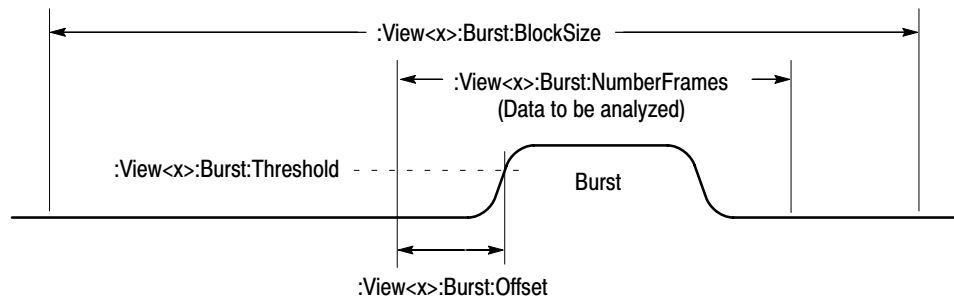

**Figure 2-8: Settings for burst analysis**

## **:View<x>:Burst:Offset (?)**

Sets or queries the start point for acquiring burst data relative to the rising edge of the burst signal. See Figure 2-8.

**Syntax**    :View<x>:Burst:Offset <value>

:View<x>:Burst:Offset?

**Arguments**    <value>::=<NR1> ranges -1024 to +1024 points. The minus values represent the data points before the rising edge.

**Examples**    :View1:Burst:Offset -10  
specifies that the analyzer acquires burst data from 10 points before the rising edge.

**Related Commands**    :View<x>:Burst:BlockSize, :View<x>:Burst:NumberFrames,  
:View<x>:Burst:Search, :View<x>:Burst:Threshold, :View<x>:Z

**:View<x>:Burst:Search (?)**

Determines whether to search a burst signal.

**Syntax** :View<x>:Burst:Search { On | Off }  
:View<x>:Burst:Search?

**Arguments** On searches a burst for analyzing.  
Off analyzes the frame specified with the :View<x>:Z command.

**Examples** :View1:Burst:Search On  
searches a burst for analyzing.

**Related Commands** :View<x>:Burst:BlockSize, :View<x>:Burst:NumberFrames,  
:View<x>:Burst:Offset, :View<x>:Burst:Threshold, :View<x>:Z

**:View<x>:Burst:Threshold (?)**

Sets or queries the threshold for determining the rising edge of a burst signal.  
See Figure 2–8.

**Syntax** :View<x>:Burst:Threshold <value>  
:View<x>:Burst:Threshold?

**Arguments** <value>::=<NR1> ranges –100 to +10 dB. The value is the relative level from  
the maximum within the burst search range.

**Examples** :View1:Burst:Threshold –20  
sets the threshold for determining the rising edge of a burst signal to –20 dB.

**Related Commands** :View<x>:Burst:BlockSize, :View<x>:Burst:NumberFrames,  
:View<x>:Burst:Offset, :View<x>:Burst:Search, :View<x>:Z

**:View<x>:Carrier (?)**

Sets or queries the carrier frequency.

**Syntax**    :View<x>:Carrier <value>  
              :View<x>:Carrier?

**Arguments**   <value>::=<NR3> ranges 0 Hz to 3 GHz.

**Examples**    :View1:Carrier 1.2G  
              sets the carrier frequency to 1.2 GHz.

**Related Commands**   :View<x>:AutoCarrier

**:View<x>:Display (?)**

Selects or queries the display data source.

**Syntax**    :View<x>:Display { Measurement | Reference }  
              :View<x>:Display?

**Arguments**   Measurement displays the measurement data.  
              Reference displays the reference data.

**Examples**    :View1:Display Measurement  
              displays the measurement data.

**Related Commands**   :View<x>:MeasDestination, :View<x>:RefDestination

**:View<x>:Format (?)**

Selects or queries the display format.

**Syntax**    :View<x>:Format { Vector | Constellation }  
              :View<x>:Format?

**Arguments**    Vector specifies the Vector format. It displays symbol-to-symbol movements using vector.

                  Constellation specifies the Constellation format. It displays only symbols.

**Examples**     :View1:Format Vector  
                  selects the Vector display format.

**:View<x>:Marker:A? (Query Only)**

Queries the amplitude at the marker position.

**Syntax**     :View<x>:Marker:A?

**Returns**    <NR3>

**Examples**    :View1:Marker:A?  
                  might return 0.789.

**Related Commands**    :View<x>:Marker:P?

**:View<x>:Marker:DeltaT (?)**

Sets or queries the delta-marker position on the time axis.

**Syntax**     :View<x>:Marker:DeltaT <value>  
              :View<x>:Marker:DeltaT?

**Arguments**   <value>::=<NR3> ranges the minimum to the maximum value on the time axis.

**Examples**     :View1:Marker:DeltaT 5.4u  
                  positions the delta marker at 5.4  $\mu$ s.

**Related Commands**   :View<x>:Marker:T

**:View<x>:Marker:P? (Query Only)**

Queries the phase at the marker position.

**Syntax**     :View<x>:Marker:P?

**Returns**    <NR3>

**Examples**     :View1:Marker:P?  
                  might return 51.313, indicating that the marker is positioned at 51.313 degrees.

**Related Commands**   :View<x>:Marker:A?

**:View<x>:Marker:T (?)**

Sets or queries the marker position on the time axis.

**Syntax**     :View<x>:Marker:T <value>  
              :View<x>:Marker:T?

**Arguments**   <value>::=<NR3> ranges the minimum to the maximum value on the time axis.

**Examples**     :View1:Marker:T 5.4u  
                  positions the marker at 5.4  $\mu$ s.

**Related Commands**     :View<x>:Marker:DeltaT?

### **:View<x>:Marker:X? (Query Only)**

Queries the horizontal position of the marker.

**Syntax**     :View<x>:Marker:X?

**Returns**     <NR3>  
                  1 represents the full-scale.

**Examples**     :View1:Marker:X?  
                  might return 0.345.

**Related Commands**     :View<x>:Marker:Y?

### **:View<x>:Marker:Y? (Query Only)**

Queries the vertical position of the marker.

**Syntax**     :View<x>:Marker:Y?

**Returns**     <NR3>  
                  1 represents the full-scale.

**Examples**     :View1:Marker:Y?  
                  might return 0.765.

**Related Commands**     :View<x>:Marker:X?

## **:View<x>:MeasDestination (?)**

Selects or queries the register pair to store the measurement data.

**Syntax**     :View<x>:MeasDestination { None | D1D2 | D3D4 | D5D6 | D7D8 }  
              :View<x>:MeasDestination?

**Arguments**   None specifies no destination.  
              D1D2 to D7D8 specify a register pair to store the measurement data.

**Examples**     :View1:MeasDestination D1D2  
              specifies the D1 and D2 register pair for storing data.

**Related Commands**   :View<x>:RefDestination

## **:View<x>:MeasFilter (?)**

Selects or queries the filter to create the measurement data.

**Syntax**     :View<x>:MeasFilter { None | RootRaisedCosine | IS95 }  
              :View<x>:MeasFilter?

**Arguments**   None selects no filter.  
              RootRaisedCosine selects the root raised-cosine filter.  
              IS95 selects the filter specified under the IS-95 standard.

**Examples**     :View1:MeasFilter RootRaisedCosine  
              selects the root raised-cosine filter to create the measurement data.

**Related Commands**   :View<x>:RefFilter



**:View<x>:Modulation (?)**

Selects or queries the digital modulation format.

**Syntax**    :View<x>:Modulation { PI4QPSK | BPSK | QPSK | PSK8 | QAM16 |  
QAM64 | GMSK | CDMAOQPSK }  
:View<x>:Modulation?

**Arguments**    PI4QPSK selects  $1/4 \pi$  Shift QPSK (Quadrature Phase Shift Keying) modulation.  
BPSK selects BPSK (Binary Phase Shift Keying) modulation.  
QPSK selects QPSK (Quadrature Phase Shift Keying) modulation.  
PSK8 selects 8PSK (Phase Shift Keying) modulation.  
QAM16 selects 16QAM (Quadrature Amplitude Modulation) modulation.  
QAM64 selects 64QAM (Quadrature Amplitude Modulation) modulation.  
GMSK selects GMSK (Gaussian-filtered Minimum Shift Keying) modulation.  
CDMAOQPSK selects CDMA OQPSK (Offset QPSK) used for the IS-95 standard.

**Examples**    :View1:Modulation PI4QPSK  
selects the  $1/4 \pi$  Shift QPSK modulation.

**:View<x>:Position (?)**

Specifies or queries which frame in a block to be displayed.

**Syntax**    :View<x>:Position <value>  
:View<x>:Position?

**Arguments**    <value>::=<NR2> ranges 0 to 100 %. It specifies the display frame position relative to the block size. 0 % specifies that the first frame in a block is displayed. 100 % represents the last frame.

**Examples**    :View1:Position 100  
displays the last frame in a block.

**:View<x>:RefDestination (?)**

Selects or queries the register pair to store the reference data.

**Syntax**    :View<x>:RefDestination { None | D1D2 | D3D4 | D5D6 | D7D8 }  
:View<x>:RefDestination?

**Arguments**    None specifies no destination.  
D1D2 to D7D8 specify the register pair to store the reference data.

**Examples**    :View1:RefDestination D1D2  
selects the D1 and D2 register pair to store the reference data.

**Related Commands**    :View<x>:MeasDestination

**:View<x>:RefFilter (?)**

Selects or queries the filter to create the reference data.

**Syntax**    :View<x>:RefFilter { None | RaisedCosine | Gaussian | IS95 }  
:View<x>:RefFilter?

**Arguments**    None selects no filter.  
RaisedCosine selects the raised cosine filter.  
Gaussian selects the Gaussian filter.  
IS95 selects the filter specified in the IS-95 standard.

**Examples**    :View1:RefFilter RaisedCosine  
selects the raised cosine filter to create the reference data.

**Related Commands**    :View<x>:MeasFilter

**:View<x>:Result<y>? (Query Only)**

Queries the measurement result.

**Syntax** :View<x>:Result<y>?

**Returns** <NR3>

Result1 returns the carrier frequency error in reference to the center frequency.

Result2 returns the origin offset.

Result3 returns the full-scale in volts.

**Examples** :View1:Result1?  
might return 15.23, indicating that the carrier frequency error is 15.23 Hz.

**:View<x>:Source (?)**

Selects or queries the display data source for the specified view.

**Syntax** :View<x>:Source { None | Active | Zoom | <file\_name> }  
:View<x>:Source?

**Arguments** None specifies no source. The display area in the view will be emptied.

Active specifies the currently acquired data as the source.

Zoom specifies the zoomed data as the source.

<file\_name>::=<string> specifies the file as the source. The file name must be “\*.IQ” (the IQ format).

**Examples** :View1:Source Active  
specifies the currently acquired data as the source.

**Related Commands** :Config:Mode

**:View<x>:Standard:CDPD (No Query Form)**

Configures the modulating system according to the CDPD (Cellular Digital Packet Data) standard.

**Syntax**     :View<x>:Standard:CDPD

**Arguments**   None

**Examples**     :View1:Standard:CDPD  
configures the modulating system according to the CPDP standard.

**:View<x>:Standard:GSM (No Query Form)**

Configures the modulating system according to the GMS (Global System for Mobile Communication) standard.

**Syntax**     :View<x>:Standard:GSM

**Arguments**   None

**Examples**     :View1:Standard:GSM  
configures the modulating system according to the GMS standard.

**:View<x>:Standard:IS95 (No Query Form)**

Configures the modulating system according to the IS-95 standard.

**Syntax**     :View<x>:Standard:IS95

**Arguments**   None

**Examples**     :View1:Standard:IS95  
configures the modulating system according to the IS-95 standard.

## **:View<x>:Standard:NADC (No Query Form)**

Configures the modulating system according to the NADC (North American Digital Cellular) standard.

**Syntax** :View<x>:Standard:NADC

**Arguments** None

**Examples** :View1:Standard:NADC  
configures the modulating system according to the NADC standard.

## **:View<x>:Standard:PDC (No Query Form)**

Configures the modulating system according to the PDC (Personal Digital Cellular System) standard.

**Syntax** :View<x>:Standard:PDC

**Arguments** None

**Examples** :View1:Standard:PDC  
configures the modulating system according to the PDC standard.

## **:View<x>:Standard:PHS (No Query Form)**

Configures the modulating system according to the PHS (Personal Handy Phone System) standard.

**Syntax** :View<x>:Standard:PHS

**Arguments** None

**Examples** :View1:Standard:PHS  
configures the modulating system according to the PHS standard.

**:View<x>:Standard:TETRA (No Query Form)**

Configures the modulating system according to the TETRA (Trans-European Trunked Radio) standard.

**Syntax**     :View<x>:Standard:TETRA

**Arguments**   None

**Examples**     :View1:Standard:TETRA  
configures the modulating system according to the TETRA standard.

**:View<x>:SymbolRate (?)**

Sets or queries the symbol rate for the digital modulation.

**Syntax**     :View<x>:SymbolRate <value>  
              :View<x>:SymbolRate?

**Arguments**   <value>::=<NR3> ranges 1/s to 30 M/s.

**Examples**     :View1:SymbolRate 8M  
sets the symbol rate to 8 M.

**:View<x>:Version?**

Queries the version of the CDMA Polar View program.

**Syntax**     :View<x>:Version?

**Returns**     <NR2>

**Examples**     :View1:Version?  
might return 1.1.

**:View<x>:Z (?)**

Specifies or queries the displayed frame number.

**Syntax**    :View<x>:Z <value>  
              :View<x>:Z?

**Arguments**    <value>::=<NR1> ranges from 0 to the number of frames – 1.

**Examples**     :View1:Z 199  
                  specifies that the frame 199 displays.





## CDMA Time View Commands

When you select `CDMATime` in the `:Config:View<x>` command, use the commands in this section to control the CDMA Time view.

**:View<x>:Average:Times (?)**

Sets or queries the number of frames that make up an averaged waveform.

**Syntax**     :View<x>:Average:Times <value>  
              :View<x>:Average:Times?

**Arguments**   <value>::=<NR1> is the number of frames for averaging, from 1 to 1000.

**Examples**     :View1:Average:Times 1000  
                  specifies that an averaged waveform will show the result of combining 1000 frames.

**:View<x>:Block (?)**

Sets or queries the block number.

**Syntax**     :View<x>:Block <value>  
              :View<x>:Block?

**Arguments**   <value>::=<NR1> ranges from 0 to the number of acquired blocks – 1.

**Examples**     :View1:Block 0  
                  sets the block number to 0.

**:View<x>:BreakMeasure (No Query Form)**

Stops the Measure function executed with the :View<x>:Measure command.

**Syntax**     :View<x>:BreakMeasure

**Arguments**   None

**Examples**     :View1:BreakMeasure  
                  stops the Measure function.

**Related Commands**   :View<x>:Measure

**:View<x>:BreakMeasureData (No Query Form)**

Stops the Measure Data function executed with the :View<x>:MeasureData command.

**Syntax** :View<x>:BreakMeasureData

**Arguments** None

**Examples** :View1:BreakMeasureData  
stops the Measure Data function.

**Related Commands** :View<x>:MeasureData

**:View<x>:Executing? (Query Only)**

Queries whether the analyzer is executing the :View<x>:Measure or :View<x>:MeasureData command.

**Syntax** :View<x>:Executing?

**Returns** On indicates that the analyzer is executing the :View<x>:Measure or :View<x>:MeasureData command.

Off indicates that the analyzer stops executing the :View<x>:Measure or :View<x>:MeasureData command.

**Examples** :View1:Executing?  
might return On, indicating that the analyzer is executing the :View<x>:Measure or :View<x>:MeasureData command.

**Related Commands** :View<x>:Measure, :View<x>:MeasureData

**:View<x>:Marker:DeltaMarker (?)**

Turns the delta marker on or off.

**Syntax**     :View<x>:Marker:DeltaMarker { On | Off }  
              :View<x>:Marker:DeltaMarker?

**Arguments**   On turns the delta marker on.  
              Off turns the delta marker off.

**Examples**     :View1:Marker:DeltaMarker On  
                  turns the delta marker on.

**Related Commands**   :View<x>:Marker:DeltaX, :View<x>:Marker:DeltaY?,  
                      :View<x>:Marker:ResetDelta

**:View<x>:Marker:DeltaX (?)**

Sets or queries the horizontal position of the delta marker.

**Syntax**     :View<x>:Marker:DeltaX <value>  
              :View<x>:Marker:DeltaX?

**Arguments**   <value>::=<NR3> ranges from the minimum (left) edge to the maximum (right) edge of the the horizontal axis.

**Examples**     :View1:Marker:DeltaX 5u  
                  positions the delta marker at 5  $\mu$ s.

**Related Commands**   :View<x>:Marker:DeltaY?

**:View<x>:Marker:DeltaY? (Query Only)**

Queries the vertical position of the delta marker.

**Syntax** :View<x>:Marker:DeltaY?

**Returns** <NR3>

**Examples** :View1:Marker:DeltaY?  
might return -50.23, indicating that the delta marker is positioned at -50.23 dBm.

**Related Commands** :View<x>:Marker:DeltaX

**:View<x>:Marker:Peak (No Query Form)**

Moves the marker to the adjacent peak in the specified direction. Note that the adjacent peak is farther than the distance specified with the :View<x>:Marker:SearchSeparation command.

**Syntax** :View<x>:Marker:Peak { 1 | -1 }

**Arguments** 1 moves the marker to the adjacent peak on the left of the marker.  
-1 moves the marker to the adjacent peak on the right of the marker.

**Examples** :View1:Marker:Peak -1  
moves the marker to the adjacent peak on the right of the marker.

**Related Commands** :View<x>:Marker:SearchMax, :View<x>:Marker:SearchMin,  
:View<x>:Marker:SearchSeparation

**:View<x>:Marker:ResetDelta (No Query Form)**

Moves the delta marker to the main marker position.

**Syntax** :View<x>:Marker:ResetDelta

**Arguments** None

**Examples** :View1:Marker:ResetDelta  
moves the delta marker to the main marker position.

**Related Commands** :View<x>:Marker:DeltaMarker

**:View<x>:Marker:SearchMax (No Query Form)**

Positions the marker on the highest signal on screen.

**Syntax** :View<x>:Marker:SearchMax

**Arguments** None

**Examples** :View1:Marker:SearchMax  
positions the marker on the highest signal on screen.

**Related Commands** :View<x>:Marker:SearchMin

**:View<x>:Marker:SearchMin (No Query Form)**

Positions the marker on the lowest signal on screen.

**Syntax** :View<x>:Marker:SearchMin

**Arguments** None

**Examples** :View1:Marker:SearchMin  
positions the marker on the lowest signal on screen.

**Related Commands** :View<x>:Marker:SearchMax

**:View<x>:Marker:SearchSeparation (?)**

Sets or queries the minimum horizontal distance to separate two peaks.

**Syntax** :View<x>:Marker:SearchSeparation <value>

**Arguments** <value>::=<NR2> specifies the minimum horizontal distance to separate two peaks. The range is 1 to 10 % relative to full-scale.

**Examples** :View1:Marker:SearchSeparation 10  
sets the minimum horizontal distance for peak separation to 10 % relative to full-scale.

**:View<x>:Marker:X (?)**

Sets or queries the horizontal position of the marker.

**Syntax**     :View<x>:Marker:X <value>  
              :View<x>:Marker:X?

**Arguments**   <value>::=<NR3> ranges from the minimum (left) edge to the maximum (right) edge of the the horizontal axis.

**Examples**     :View1:Marker:X 5u  
                  positions the marker at 5  $\mu$ s.

**Related Commands**   :View<x>:Marker:Y?

**:View<x>:Marker:Y? (Query Only)**

Queries the vertical position of the marker.

**Syntax**     :View<x>:Marker:Y?

**Returns**    <NR3>

**Examples**     :View1:Marker:Y?  
                  might return -50.23, indicating that the marker is positioned at -50.23 dBm.

**Related Commands**   :View<x>:Marker:X



**:View<x>:Mask:OffLeft (?)**

Sets or queries the mask time just before the rising edge of waveform (see Figure 2–9).

**Syntax**     :View<x>:Mask:OffLeft <value>  
              :View<x>:Mask:OffLeft?

**Arguments**   <value>::=<NR3> ranges 0 to 1.6 ms.

**Examples**     :View1:Mask:OffLeft 0.2m  
                  sets the mask time just before the rising edge of waveform to 0.2 ms.

**Related Commands**   :View<x>:Mask:OffRight

**:View<x>:Mask:OffLevel (?)**

Sets or queries the mask level for the off state (see Figure 2–9).

**Syntax**     :View<x>:Mask:OffLevel <value>  
              :View<x>:Mask:OffLevel?

**Arguments**   <value>::=<NR3> ranges –100 dB to 0 dB.

**Examples**     :View1:Mask:OffLevel –60  
                  sets the mask level for the off state to –60 dB.

**Related Commands**   :View<x>:Mask:OnLevel

## :View<x>:Mask:OffRight (?)

Sets or queries the mask time just after the falling edge of waveform (see Figure 2-9).

**Syntax** :View<x>:Mask:OffRight <value>  
:View<x>:Mask:OffRight?

**Arguments** <value>::=<NR3> ranges 0 to 1.6 ms.

**Examples** :View1:Mask:OffRight 1.2m  
sets the mask time just after the falling edge of waveform to 1.2 ms.

**Related Commands** :View<x>:Mask:OffLeft

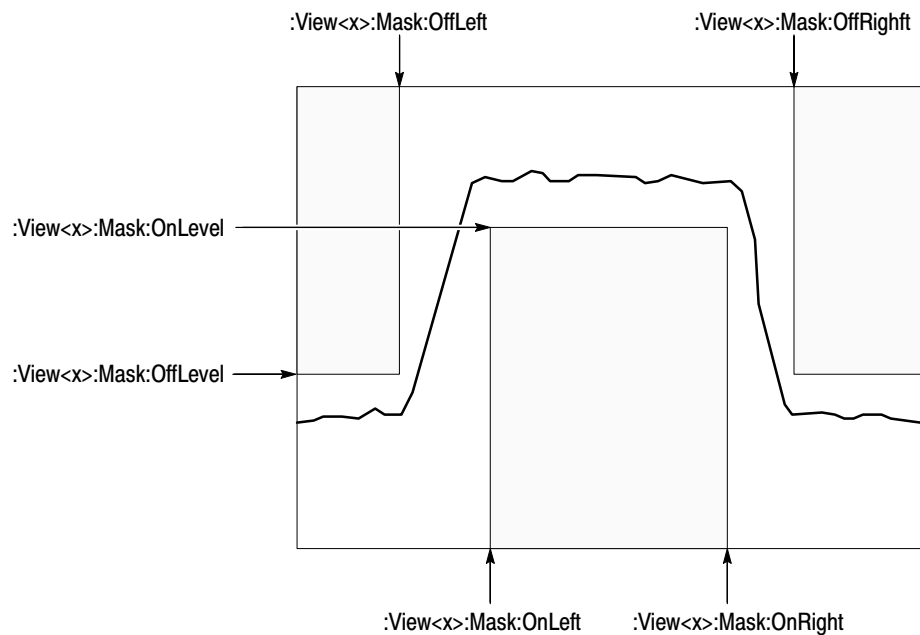

**Figure 2-9: Setting the trigger mask**

**:View<x>:Mask:OnLeft (?)**

Sets or queries the mask time just after the rising edge of waveform (see Figure 2–9).

**Syntax**     :View<x>:Mask:OnLeft <value>  
              :View<x>:Mask:OnLeft?

**Arguments**   <value>::=<NR3> ranges 0 to 1.6 ms.

**Examples**     :View1:Mask:OnLeft 0.8m  
              sets the mask time just after the rising edge of waveform to 0.8 ms.

**Related Commands**   :View<x>:Mask:OnLeft

**:View<x>:Mask:OnLevel (?)**

Sets or queries the mask level for the on state (see Figure 2–9).

**Syntax**     :View<x>:Mask:OnLevel <value>  
              :View<x>:Mask:OnLevel?

**Arguments**   <value>::=<NR3> ranges –100 dB to 0 dB.

**Examples**     :View1:Mask:OnLevel –30  
              sets the mask level for the on state to –30 dB.

**Related Commands**   :View<x>:Mask:OffLevel

**:View<x>:Mask:OnRight (?)**

Sets or queries the mask time just before the falling edge of waveform (see Figure 2–9).

**Syntax**     :View<x>:Mask:OnRight <value>  
              :View<x>:Mask:OnRight?

**Arguments**   <value>::=<NR3> ranges 0 to 1.6 ms.

**Examples**     :View1:Mask:OnRight 1.2m  
              sets the mask time just before the falling edge of waveform to 1.2 ms.

**Related Commands**   :View<x>:Mask:OnLeft

## **:View<x>:Measure (No Query Form)**

Measures the CDMA time characteristics of the input signal. The Pass/Fail decision is made by comparing the averaged waveform with the mask settings.

The analyzer executes this command on the background. Use the :View<x>:Executing? query command to check if the :View<x>:Measure command is in operation.

**Syntax** :View<x>:Measure

**Arguments** None

**Examples** :View1:Measure  
measures the input signal and performs the Pass/Fail test.

**Related Commands** :View<x>:Average:Times, :View<x>:Mask command group,  
:View<x>:MeasureData, :View<x>:Executing?

## **:View<x>:MeasureData (No Query Form)**

Measures the CDMA time characteristics of the waveforms already stored in memory, such as loaded from a file. The Pass/Fail decision is made by comparing the averaged waveform with the mask settings.

The analyzer executes this command on the background. Use the :View<x>:Executing? query command to check if the :View<x>:Measure command is in operation.

**Syntax** :View<x>:MeasureData

**Arguments** None

**Examples** :View1:MeasureData  
measures the stored waveforms and performs the Pass/Fail test.

**Related Commands** :View<x>:Average:Times, :View<x>:Mask command group,  
:View<x>:Measure, :View<x>:Executing?

**:View<x>:Position (?)**

Specifies or queries which frame in a block to be displayed.

**Syntax**    :View<x>:Position <value>  
              :View<x>:Position?

**Arguments**    <value>::=<NR2> ranges 0 to 100 %. It specifies the display frame position relative to the block size. 0 % specifies that the first frame in a block is displayed. 100 % represents the last frame.

**Examples**    :View1:Position 100  
              displays the last frame in a block.

**:View<x>:Result<y>? (Query Only)**

Queries the measurement result.

**Syntax**    :View<x>:Result<y>?

**Returns**    Result1::=<NR3> returns the number of averages.  
              Result2::=<NR3> returns the average power of the on state.  
              Result3::=<NR3> returns the average power of the off state.  
              Result4::=<NR3> returns the on/off power ratio.  
              Result5::={ Pass | Fail } returns the result of spurious test.

**Examples**    :View1:Result2?  
              returns -17.635, indicating the average power of the on state is -17.635 dB.

**Related Commands**    :View<x>:Measure, :View<x>:MeasureData

**:View<x>:Scale:FallingEdge (No Query Form)**

Expands the falling edge of the waveform on screen.

**Syntax** :View<x>:Scale:FallingEdge

**Arguments** None

**Examples** :View1:Scale:FallingEdge  
expands the falling edge of the waveform on screen.

**Related Commands** :View<x>:Scale:RisingEdge

**:View<x>:Scale:FullScale (No Query Form)**

Displays the whole waveform.

**Syntax** :View<x>:Scale:FullScale

**Arguments** None

**Examples** :View1:Scale:FullScale  
displays the whole waveform.

**Related Commands** :View<x>:Scale:RisingEdge, :View<x>:Scale:FallingEdge

**:View<x>:Scale:HoldYScale (?)**

Determines whether to hold or reset the vertical scale when you change the input source.

**Syntax**    :View<x>:Scale:HoldYScale { On | Off }  
              :View<x>:Scale:HoldYScale?

**Arguments**    On holds the vertical scale setting when you change the input source.  
                  Off resets the vertical scale to full-scale.

**Examples**     :View1:Scale:HoldYScale On  
                  holds the vertical scale setting when you change the input source.

**Related Commands**    :View<x>:Scale:YScale, :View<x>:Scale:YStart, :View<x>:Source

**:View<x>:Scale:RisingEdge (No Query Form)**

Expands the rising edge of the waveform on screen.

**Syntax**        :View<x>:Scale:RisingEdge

**Arguments**    None

**Examples**     :View1:Scale:RisingEdge  
                  expands the rising edge of the waveform on screen.

**Related Commands**    :View<x>:Scale:FallingEdge



**:View<x>:Scale:XScale (?)**

Sets or queries the horizontal axis full-scale to display a portion of the data.

**Syntax**    :View<x>:Scale:XScale <value>  
              :View<x>:Scale:XScale?

**Arguments**    <value>::=<NR3> ranges full-scale/256 to full-scale of the acquired data.

**Examples**     :View1:Scale:XScale 800u  
                  sets the horizontal axis full-scale to 800  $\mu$ s.

**Related Commands**    :View<x>:Scale:XStart, :View<x>:Scale:YScale

**:View<x>:Scale:XStart (?)**

Sets or queries the value represented by the minimum (left) edge of the horizontal axis.

**Syntax**        :View<x>:Scale:XStart <value>  
                  :View<x>:Scale:XStart?

**Arguments**    <value>::=<NR3> ranges from the minimum to the maximum value on the horizontal axis of the acquired data.

**Examples**     :View1:Scale:XStart 100u  
                  sets the value represented by the left edge of the horizontal axis to 100  $\mu$ s.

**Related Commands**    :View<x>:Scale:XScale

**:View<x>:Scale:YScale (?)**

Sets or queries the vertical axis full-scale to display a portion of the data.

**Syntax**     :View<x>:Scale:YScale <value>  
              :View<x>:Scale:YScale?

**Arguments**   <value>::=<NR3> ranges full-scale/100 to full-scale of the acquired data.

**Examples**     :View1:Scale:YScale 20  
                  sets the vertical axis full-scale to 20 dB.

**Related Commands**   :View<x>:Scale:XScale

**:View<x>:Scale:YStart (?)**

Sets or queries the value represented by the minimum (bottom) edge of the vertical axis.

**Syntax**     :View<x>:Scale:YStart <value>  
              :View<x>:Scale:YStart?

**Arguments**   <value>::=<NR3> ranges from the reference level – 200 dB to the reference level + 100 dB.

**Examples**     :View1:Scale:YStart -120  
                  sets the value represented by the bottom edge of the vertical axis to –120 dB.

**Related Commands**   :View<x>:Scale:YScale

**:View<x>:Source (?)**

Selects or queries the display data source for the specified view.

**Syntax**    :View<x>:Source { None | Active | Zoom | <file\_name> }  
              :View<x>:Source?

**Arguments**    None specifies no source. The display area in the view will be emptied.  
                  Active specifies the currently acquired data as the source.  
                  Zoom specifies the zoomed data as the source.  
                  <file\_name>::=<string> specifies the file as the source. The file name must be "\*.IQ" (the IQ format).

**Examples**      :View1:Source Active  
                  specifies the currently acquired data as the source.

**Related Commands**    :Config:Mode

**:View<x>:Trace2:TraceVisible (?)**

Determines whether or not to display the Trace 2 (averaged waveform).

**Syntax**        :View<x>:Trace2:TraceVisible { On | Off }  
                  :View<x>:Trace2:TraceVisible?

**Arguments**    On displays the Trace 2 (averaged waveform).  
                  Off does not display the Trace 2.

**Examples**      :View1:Trace2:TraceVisible On  
                  displays the Trace 2.

**Related Commands**    :View<x>:TraceVisible

**:View<x>:TraceVisible (?)**

Determines whether or not to display the Trace 1 (acquired waveform).

**Syntax**    :View<x>:TraceVisible { On | Off }  
              :View<x>:TraceVisible?

**Arguments**   On displays the Trace 1 (acquired waveform).  
              Off does not display the Trace 1.

**Examples**     :View1:TraceVisible On  
                  displays the Trace 1.

**Related Commands**   :View<x>:Trace2:TraceVisible

**:View<x>:Version? (Query Only)**

Queries the version of the CDMA Time View program.

**Syntax**       :View<x>:Version?

**Returns**      <NR2>

**Examples**     :View1:Version?  
                  might return 1.1.

# CodeSpectrogram View Commands (3066 Option 15 and 3086 Option 16 Only)

When you select CodeSpectrogram in the `Config:View<x>` command, use the commands in this section to control the code-domain power spectrogram view. This view incorporates analysis functions for the cdmaOne standard.

## **:View<x>:Marker:DeltaMarker (?)**

Turns the delta marker on or off.

**Syntax**    :View<x>:Marker:DeltaMarker { On | Off }  
              :View<x>:Marker:DeltaMarker?

**Arguments**    On turns the delta marker on.  
                  Off turns the delta marker off

**Examples**     :View1:Marker:DeltaMarker On  
                  turns the delta marker on.

**Related Commands**    :View<x>:Marker:ResetDelta

## **:View<x>:Marker:ResetDelta (No Query Form)**

Moves the delta marker to the main marker position.

**Syntax**        :View<x>:Marker:ResetDelta

**Arguments**    None

**Examples**     :View1:Marker:ResetDelta

**Related Commands**    :View<x>:Marker:DeltaMarker

### **:View<x>:Marker:SearchMax (No Query Form)**

Positions the marker on the highest signal on screen.

**Syntax** :View<x>:Marker:SearchMax

**Arguments** None

**Examples** :View1:Marker:SearchMax  
positions the marker on the highest signal on screen.

**Related Commands** :View<x>:Marker:SearchMin

### **:View<x>:Marker:SearchMin (No Query Form)**

Positions the marker on the lowest signal on screen.

**Syntax** :View<x>:Marker:SearchMin

**Arguments** None

**Examples** :View1:Marker:SearchMin  
positions the marker on the lowest signal on screen.

**Related Commands** :View<x>:Marker:SearchMax

**:View<x>:Marker:SearchSeparation (?)**

Sets or queries the minimum horizontal distance to separate two peaks.

**Syntax** :View<x>:Marker:SearchSeparation <value>

**Arguments** <value>::=<NR2> specifies the minimum horizontal distance to separate two peaks. The range is 1 to 10 % relative to full-scale.

**Examples** :View1:Marker:SearchSeparation 10  
sets the minimum horizontal distance for peak separation to 10 % relative to full-scale.

**Related Commands** :View<x>:Scale:XScale

**:View<x>:Marker:X (?)**

Sets or queries the horizontal position of the marker.

**Syntax** :View<x>:Marker:X <value>

:View<x>:Marker:X?

**Arguments** <value>::=<NR3> ranges from the minimum (left) edge to the maximum (right) edge of the the horizontal axis (channel).

**Examples** :View1:Marker:X 32  
positions the marker at channel 32.

**Related Commands** :View<x>:Marker:Z, :View<x>:Scale:XScale, :View<x>:Scale:XStart



**:View<x>:Marker:Z (?)**

Sets or queries the marker position on the vertical (symbol number) axis.

**Syntax** :View<x>:Marker:Z <value>  
:View<x>:Marker:Z?

**Arguments** <value>::=<NR1> ranges 0 to the number of symbols – 1.

**Examples** :View1:Marker:Z 199  
positions the marker at the symbol number 199.

**Related Commands** :View<x>:Marker:X, :View<x>:Scale:ZScale, :View<x>:Scale:ZStart

**:View<x>:Monochrome (?)**

Determines whether to display a spectrogram in monochrome.

**Syntax** :View<x>:Monochrome { On | Off }  
:View<x>:Monochrome?

**Arguments** On displays a spectrogram in monochrome.  
Off displays a spectrogram in color.

**Examples** :View1:Monochrome On  
displays a spectrogram in monochrome.

**:View<x>:NumberColors (?)**

Selects or queries the number of display colors.

**Syntax**    :View<x>:NumberColors { 10 | 100 }  
              :View<x>:NumberColors?

**Arguments**   10 selects the 10-color display.  
              100 selects the 100-color display (default).

**Examples**    :View1:NumberColors 100  
              selects the 100-color display.

**Related Commands**   :View<x>:Scale:YScale, :View<x>:Scale:YStart

**:View<x>:Scale:AutoScale (No Query Form)**

Resets the Y (color) axis scale to the default setting.

**Syntax**    :View<x>:Scale:AutoScale

**Arguments**   None

**Examples**    :View1:Scale:AutoScale  
              resets the Y (color) axis scale to the default setting.

**Related Commands**   :View<x>:Scale:YScale

**:View<x>:Scale:XScale (?)**

Sets or queries the horizontal axis (channel) full-scale to display a portion of data.

**Syntax**    :View<x>:Scale:XScale <value>  
              :View<x>:Scale:XScale?

**Arguments** <value>::=<NR1> ranges 16 to 64 channels.

**Examples**    :View1:Scale:XScale 64  
              sets the horizontal axis full-scale to 64 channels.

**Related Commands**   :View<x>:Scale:XStart, :View<x>:Scale:YScale, :View<x>:Scale:ZScale

**:View<x>:Scale:XStart (?)**

Sets or queries the value represented by the minimum (left) edge of the horizontal axis (channel).

**Syntax**    :View<x>:Scale:XStart <value>  
              :View<x>:Scale:XStart?

**Arguments** <value>::=<NR1> ranges from 0 to 64 – (the horizontal axis full-scale) channels.

**Examples**    :View1:Scale:XStart 0  
              sets the value represented by the left edge of the horizontal axis to channel 0.

**Related Commands**   :View<x>:Scale:XScale

**:View<x>:Scale:YScale (?)**

Sets or queries the Y (color) axis full-scale to display a portion of data.

**Syntax**     :View<x>:Scale:YScale <value>  
              :View<x>:Scale:YScale?

**Arguments**   <value>::=<NR3> is 10, 20, 50, or 100 dB.

**Examples**     :View1:Scale:YScale 50  
              sets the Y axis full-scale to 50 dB.

**Related Commands**   :View<x>:Scale:XScale, :View<x>:Scale:YStart, :View<x>:Scale:ZScale

**:View<x>:Scale:YStart (?)**

Sets or queries the value represented by the minimum (bottom) edge of the Y (color) axis.

**Syntax**     :View<x>:Scale:YStart <value>  
              :View<x>:Scale:YStart?

**Arguments**   <value>::=<NR3> ranges from ref level – 200 dB to ref level + 100 dB  
              – horizontal axis full-scale.

**Examples**     :View1:Scale:YStart -50  
              sets the value represented by the bottom edge of the Y axis to –50 dBm.

**Related Commands**   :View<x>:Scale:YScale

**:View<x>:Scale:ZScale (?)**

Sets or queries the symbol display interval. The spectrogram is displayed every specified number of symbols.

**Syntax**    :View<x>:Scale:ZScale <value>  
               :View<x>:Scale:ZScale?

**Arguments**    <value>::=<NR1> ranges 1 to 32.  
                   1 means every symbol is displayed. 32 means every 32<sup>th</sup> symbol is displayed.

**Examples**     :View1:Scale:ZScale 8  
                   displays a spectrogram every 8<sup>th</sup> symbol.

**Related Commands**    :View<x>:Scale:XScale, :View<x>:Scale:YScale, :View<x>:Scale:ZStart

**:View<x>:Scale:ZStart (?)**

Sets or queries the value represented by the minimum (bottom) edge of the Z (symbol number) axis, i.e. the first symbol to be displayed.

**Syntax**        :View<x>:Scale:ZStart <value>  
                   :View<x>:Scale:ZStart?

**Arguments**    <value>::=<NR1> ranges 0 to the number of symbols – 1.

**Examples**     :View1:Scale:ZStart 20  
                   sets the value represented by the bottom edge of the Z axis to 20.

**Related Commands**    :View<x>:Scale:ZScale

## **:View<x>:Version? (Query Only)**

Queries the version of the CodeSpectrogram View program.

**Syntax**     :View<x>:Version?

**Returns**    <NR2>

**Examples**    :View1:Version?  
                might return 1.1.

## **:View<x>:ZGap (?)**

Sets or queries the display interval between two adjacent symbols on the Z (symbol number) axis on screen.

**Syntax**     :View<x>:ZGap <value>  
              :View<x>:ZGap?

**Arguments**   <value>::=<NR1> ranges 1 to 10 pixels.

**Examples**    :View1:ZGap 10  
                sets the display interval between two adjacent symbols on the Z axis to 10 pixels.

# CodePolar View Commands

## (3066 Option 15 and 3086 Option 16 Only)

When you select CodePolar in the `:Config:View<x>` command, use the commands in this section to control the polar view. This view incorporates analysis functions for the cdmaOne standard.

For information on the polar view, refer to the *User Manual*.

**:View<x>:AlphaBT (?)**

Sets or queries the  $\alpha$ /BT value.

**Syntax**     :View<x>:AlphaBT <value>  
              :View<x>:AlphaBT?

**Arguments**   <value>::=<NR2> ranges 0.0001 to 1.

**Examples**     :View1:AlphaBT 1  
                  sets the  $\alpha$ /BT value to 1.

**:View<x>:Analysis:TimeSlot (?)**

Specifies or queries the symbol number to display the constellation.

**Syntax**     :View<x>:Analysis:TimeSlot <value>  
              :View<x>:Analysis:TimeSlot?

**Arguments**   <value>::=<NR1> ranges 0 to the number of symbols – 1.

**Examples**     :View1:Analysis:TimeSlot 1  
                  sets the symbol number to 1.

**:View<x>:Analyze (No Query Form)**

Performs analysis on the background for all symbols acquired.

**Syntax**     :View<x>:Analyze

**Arguments**   None

**Examples**     :View1:Analyze  
                  performs analysis on the background for all symbols acquired.

**Related Commands**   :View<x>:BreakAnalyze



**:View<x>:AutoCarrier (?)**

Determines whether to search the carrier automatically for each frame.

**Syntax**    :View<x>:AutoCarrier { On | Off }  
              :View<x>:AutoCarrier?

**Arguments**    On searches the carrier automatically for each frame, and displays the frequency error in reference to the center frequency on screen at `Freq Error`.  
  
                  Off sets the carrier frequency to the value specified with the `:View<x>:Carrier` command.

**Examples**      :View1:AutoCarrier On  
                  searches the carrier automatically and displays the frequency error.

**Related Commands**    :View<x>:Carrier

**:View<x>:BreakAnalyze (No Query Form)**

Breaks the analysis executed by the `:View<x>:Analyze` command.

**Syntax**        :View<x>:BreakAnalyze

**Arguments**    None

**Examples**      :View1:Analyze  
                  breaks the analysis.

**Related Commands**    :View<x>:Analyze

**:View<x>:Carrier (?)**

Sets or queries the carrier frequency.

**Syntax**     :View<x>:Carrier <value>  
              :View<x>:Carrier?

**Arguments**   <value>::=<NR3> ranges 0 Hz to 3 GHz.

**Examples**     :View1:Carrier 1.2G  
                  sets the carrier frequency to 1.2 GHz.

**Related Commands**   :View<x>:AutoCarrier

**:View<x>:Display (?)**

Selects or queries the display data source.

**Syntax**     :View<x>:Display { Measurement | Reference }  
              :View<x>:Display?

**Arguments**   Measurement displays the measurement data.  
              Reference displays the reference data.  
              Refer to the *User Manual* on the measurement and reference data.

**Examples**     :View1:Display Measurement  
                  displays the measurement data.

**Related Commands**   :View<x>:MeasFilter, :View<x>:RefFilter

**:View<x>:Format (?)**

Selects or queries the waveform display format.

**Syntax**    :View<x>:Format { Vector | Constellation }  
              :View<x>:Format?

**Arguments**    Vector specifies the Vector format. It displays symbol-to-symbol movements using vector.

                  Constellation specifies the Constellation format. It displays only symbols.

**Examples**     :View1:Format Vector  
                  selects the Vector display format.

**:View<x>:Marker:T (?)**

Sets or queries the marker position on the time axis.

**Syntax**     :View<x>:Marker:T <value>  
              :View<x>:Marker:T?

**Arguments**    <value>::=<NR3> ranges 0 to the time length of the acquisition data.

**Examples**     :View1:Marker:T 5.4u  
                  positions the marker at 5.4  $\mu$ s.

## **:View<x>:MeasFilter (?)**

Selects or queries the filter to create the measurement data.

**Syntax**    :View<x>:MeasFilter { None | RootRaisedCosine }  
              :View<x>:MeasFilter?

**Arguments**    None selects no filter.  
                  RootRaisedCosine selects the root raised-cosine filter.

**Examples**     :View1:MeasFilter RootRaisedCosine  
                  selects the root raised-cosine filter to create the measurement data.

**Related Commands**    :View<x>:RefFilter

## **:View<x>:Modulation (?)**

Selects or queries the modulation type.

**Syntax**        :View<x>:Modulation { IS95 | IS95+EQ }  
                  :View<x>:Modulation?

**Arguments**    IS95 selects the modulation without the equalizer according to the IS-95 standard.  
                  IS95+EQ selects the modulation with the equalizer according to the IS-95 standard.

**Examples**     :View1:Modulation IS95+EQ  
                  selects the modulation with the equalizer according to the IS-95 standard.

**:View<x>:RefFilter (?)**

Selects or queries the filter to create the reference data.

**Syntax** :View<x>:RefFilter { None | RaisedCosine | Gaussian | IS95 }  
:View<x>:RefFilter?

**Arguments** None selects no filter.  
RaisedCosine selects the raised cosine filter.  
Gaussian selects the Gaussian filter.  
IS95 selects the IS-95 filter.

**Examples** :View1:RefFilter RaisedCosine  
selects the raised cosine filter to create the reference data.

**Related Commands** :View<x>:MeasFilter

**:View<x>:Source (?)**

Selects or queries the input data source for the view.

**Syntax** :View<x>:Source { None | Active | Zoom | <file\_name> }  
:View<x>:Source?

**Arguments** None specifies no source. The display area in the view will be emptied.  
Active specifies the currently acquired data as the source.  
Zoom specifies the zoomed data as the source.  
<file\_name>::=<string> specifies the data file as the source. The file name must be “\*.IQ” (the IQ format).

**Examples** :View1:Source Active  
specifies the currently acquired data as the source.

## **:View<x>:Standard:IS95 (No Query Form)**

Configures the modulating system without the equalizer according to the IS-95 standard.

**Syntax**      :View<x>:Standard:IS95

**Arguments**    None

**Examples**      :View1:Standard:IS95  
configures the modulating system without the equalizer according to the IS-95 standard.

**Related Commands**    :View<x>:Standard:IS95EQ

## **:View<x>:Standard:IS95EQ (No Query Form)**

Configures the modulating system with the equalizer according to the IS-95 standard.

**Syntax**      :View<x>:Standard:IS95EQ

**Arguments**    None

**Examples**      :View1:Standard:IS95EQ  
configures the modulating system with the equalizer according to the IS-95 standard.

**Related Commands**    :View<x>:Standard:IS95

**:View<x>:SymbolRate (?)**

Sets or queries the chip rate.

**Syntax**    :View<x>:SymbolRate <value>  
              :View<x>:SymbolRate?

**Arguments**    <value>::=<NR3> ranges 1/s to 30 M/s.

**Examples**     :View1:SymbolRate 8M  
                  sets the chip rate to 8 M/s.

**:View<x>:Version? (Query Only)**

Queries the version of the CodePolar View program.

**Syntax**        :View<x>:Version?

**Returns**       <NR2>

**Examples**     :View1:Version?  
                  might return 1.1.





# CodePower View Commands

## (3066 Option 15 and 3086 Option 16 Only)

When you select CodePower in the `Config:View<x>` command, use the commands in this section to set the details for the code-domain power view. This view incorporates analysis functions for the cdmaOne standard.

**:View<x>:Average (?)**

Determines whether or not to display the results of averaging on the analyzer screen.

**Syntax**     :View<x>:Average { On | Off }  
              :View<x>:Average?

**Arguments**   On displays the results of averaging. The averaged power is displayed for each channel with a bar graph.

Off hides the results of averaging.

**Examples**     :View1:Average On  
                  displays the results of averaging.

**Related Commands**   :View<x>:Average:Execute

**:View<x>:Average:AllFrames (No Query Form)**

Specifies that all of the acquired symbol data are used for averaging.

**Syntax**     :View<x>:AllFrames

**Arguments**   None

**Examples**     :View1:AllFrames  
                  specifies that all of acquired symbol data are used for averaging.

**Related Commands**   :View<x>:Average:BeginZ, :View<x>:Average:EndZ

**:View<x>:Average:BeginZ (?)**

Sets or queries the uppermost symbol in the average range.

**Syntax** :View<x>:Average:BeginZ <value>  
:View<x>:Average:BeginZ?

**Arguments** <value>::=<NR1> ranges 0 to the number of symbols – 1.

**Examples** :View1:Average:BeginZ 199  
sets the uppermost symbol number to 199.

**Related Commands** :View<x>:Average:EndZ

**:View<x>:Average:EndZ (?)**

Sets or queries the lowermost symbol in the average range.

**Syntax** :View<x>:Average:EndZ <value>  
:View<x>:Average:EndZ?

**Arguments** <value>::=<NR1> ranges 0 to the number of symbols – 1.

**Examples** :View1:Average:EndZ 100  
sets the lowermost symbol number to 100.

**Related Commands** :View<x>:Average:BeginZ

## **:View<x>:Average:Execute (No Query Form)**

Performs averaging for each bin for symbols in the specified range.

**Syntax** :View<x>:Average:Execute

**Arguments** None

**Examples** :View1:Average:Execute  
performs averaging for each bin for symbols in the specified range.

**Related Commands** :View<x>:Average:AllFrames, :View<x>:Average:BeginZ,  
:View<x>:Average:EndZ

## **:View<x>:Average:MarkerToFrame (No Query Form)**

Specifies that the symbols between the main marker and the delta marker are averaged.

**Syntax** :View<x>:MarkerToFrame

**Arguments** None

**Examples** :View<x>:MarkerToFrame  
specifies that the symbols between the main marker and the delta marker are averaged.

**Related Commands** :View<x>:Average:BeginZ, :View<x>:Average:EndZ

**:View<x>:Average:Times (?)**

Sets or queries the number of waveform acquisitions that make up an averaged waveform.

**Syntax**    :View<x>:Average:Times <value>  
               :View<x>:Average:Times?

**Arguments**    <value>::=<NR1> ranges 1 to 1,000,000.

**Examples**        :View1:Average:Times 1000  
 specifies that an averaged waveform will show the result of combining 1000 separately acquired waveforms.

**Related Commands**    :View<x>:Average:Type

**:View<x>:Average:Type (?)**

Selects or queries the average type. You can also select the peak hold mode. For more information about averaging, refer to the *User Manual*.

**Syntax**        :View<x>:Average:Type { RMSExpo | RMS | MaxHold | MinHold }  
               :View<x>:Average:Type?

**Arguments**        RMSExpo averages with the RMS (root mean squared) exponential. This mode weights older acquisition data so that they have a progressively smaller effect on the average.

RMS averages with the RMS (root mean squared).

MaxHold holds the maximum value for each data point.

MinHold holds the minimum value for each data point.

**Examples**        :View1:Average:Type RMSExpo  
 averages the waveform with the exponential RMS.

**Related Commands**    :View<x>:Average:Time

## **:View<x>:Marker:DeltaMarker (?)**

Turns the delta marker on or off.

**Syntax**    :View<x>:Marker:DeltaMarker { On | Off }  
              :View<x>:Marker:DeltaMarker?

**Arguments**    On turns the delta marker on.  
                  Off turns the delta marker off.

**Examples**     :View1:Marker:DeltaMarker On  
                  turns the delta marker on.

**Related Commands**    :View<x>:Marker:ResetDelta

## **:View<x>:Marker:ResetDelta (No Query Form)**

Moves the delta marker to the main marker position.

**Syntax**        :View<x>:Marker:ResetDelta

**Arguments**    None

**Examples**     :View1:Marker:ResetDelta  
                  moves the delta marker to the main marker position.

**Related Commands**    :View<x>:Marker:DeltaMarker

## **:View<x>:Marker:SearchMax (No Query Form)**

Positions the marker on the highest signal on screen.

**Syntax**        :View<x>:Marker:SearchMax

**Arguments**    None

**Examples** :View1:Marker:SearchMax  
positions the marker on the highest signal on screen.

**Related Commands** :View<x>:Marker:SearchMin

### **:View<x>:Marker:SearchMin (No Query Form)**

Positions the marker on the lowest signal on screen.

**Syntax** :View<x>:Marker:SearchMin

**Arguments** None

**Examples** :View1:Marker:SearchMin  
positions the marker on the lowest signal on screen.

**Related Commands** :View<x>:Marker:SearchMax

### **:View<x>:Marker:SearchSeparation (?)**

Sets or queries the minimum horizontal distance to separate two peaks.

**Syntax** :View<x>:Marker:SearchSeparation <value>

**Arguments** <value>::=<NR2> specifies the minimum horizontal distance to separate two peaks. The range is 1 to 10 % relative to full-scale.

**Examples** :View1:Marker:SearchSeparation 10  
sets the minimum horizontal distance for peak separation to 10 % relative to full-scale.

**Related Commands** :View<x>:Scale:XScale

## **:View<x>:Marker:X (?)**

Sets or queries the horizontal position of the marker.

**Syntax**     :View<x>:Marker:X <value>  
              :View<x>:Marker:X?

**Arguments**   <value>::=<NR1> ranges from the minimum (left) edge to the maximum (right) edge of the the horizontal axis (channel).

**Examples**     :View1:Marker:X 32  
                  positions the marker at channel 32.

**Related Commands**   :View<x>:Scale:XScale, :View<x>:Scale:XStart

## **:View<x>:Scale:AutoScale (No Query Form)**

Resets the vertical axis (power) to the default setting.

**Syntax**     :View<x>:Scale:AutoScale

**Arguments**   None

**Examples**     :View1:Scale:AutoScale  
                  resets the vertical axis (power) to the default setting.

**Related Commands**   :View<x>:Scale:YScale



**:View<x>:Scale:XScale (?)**

Sets or queries the horizontal axis (channel) full-scale to display a portion of data.

**Syntax**    :View<x>:Scale:XScale <value>  
              :View<x>:Scale:XScale?

**Arguments**    <value>::=<NR1> ranges 16 to 64 channels.

**Examples**     :View1:Scale:XScale 64  
                  sets the horizontal axis full-scale to 64 channels.

**Related Commands**    :View<x>:Scale:XStart, :View<x>:Scale:YScale

**:View<x>:Scale:XStart (?)**

Sets or queries the value represented by the minimum (left) edge of the horizontal axis (channel).

**Syntax**        :View<x>:Scale:XStart <value>  
                  :View<x>:Scale:XStart?

**Arguments**    <value>::=<NR1> ranges from 0 to 64 – (the horizontal axis full-scale) channels.

**Examples**     :View1:Scale:XStart 0  
                  sets the value represented by the left edge of the horizontal axis to 0.

**Related Commands**    :View<x>:Scale:XScale

**:View<x>:Scale:YScale (?)**

Sets or queries the vertical axis (power) full-scale to display a portion of data.

**Syntax**     :View<x>:Scale:YScale <value>  
              :View<x>:Scale:YScale?

**Arguments**   <value>::=<NR3> ranges 1 to 100 dB.

**Examples**     :View1:Scale:YScale 50  
              sets the vertical axis full-scale to 50 dB.

**Related Commands**   :View<x>:Scale:XScale, :View<x>:Scale:YStart

**:View<x>:Scale:YStart (?)**

Sets or queries the value represented by the minimum (bottom) edge of the vertical axis (power).

**Syntax**     :View<x>:Scale:YStart <value>  
              :View<x>:Scale:YStart?

**Arguments**   <value>::=<NR3> ranges from ref level – 200 dB to ref level + 100 dB  
              – horizontal axis full-scale.

**Examples**     :View1:Scale:YStart -50  
              sets the value represented by the bottom edge of the vertical axis to –50 dB.

**Related Commands**   :View<x>:Scale:YScale

**:View<x>:Version? (Query Only)**

Queries the version of the CodePower View program.

**Syntax**     :View<x>:Version?

**Returns**    <NR2>

**Examples**    :View1:Version?  
                might return 1.1.

**:View<x>:Z (?)**

Specifies or queries the displayed symbol number.

**Syntax**     :View<x>:Z <value>

              :View<x>:Z?

**Arguments**   <value>::=<NR1> ranges from 0 to the number of symbols – 1.

**Examples**    :View1:Z 199  
                specifies that the symbol 199 displays.



# CodeWSpectrogram View Commands (3086 Option 16 Only)

When you select CodeWSpectrogram in the `Config:View<x>` command, use the commands in this section to control the code-domain power spectrogram view. This view incorporates analysis functions for the W-CDMA standard.

## **:View<x>:Marker:DeltaMarker (?)**

Turns the delta marker on or off.

**Syntax**     :View<x>:Marker:DeltaMarker { On | Off }  
              :View<x>:Marker:DeltaMarker?

**Arguments**   On turns the delta marker on.  
              Off turns the delta marker off

**Examples**     :View1:Marker:DeltaMarker On  
                  turns the delta marker on.

**Related Commands**   :View<x>:Marker:ResetDelta

## **:View<x>:Marker:ResetDelta (No Query Form)**

Moves the delta marker to the main marker position.

**Syntax**     :View<x>:Marker:ResetDelta

**Arguments**   None

**Examples**     :View1:Marker:ResetDelta

**Related Commands**   :View<x>:Marker:DeltaMarker

**:View<x>:Marker:SearchMax (No Query Form)**

Positions the marker on the highest signal on screen.

**Syntax** :View<x>:Marker:SearchMax

**Arguments** None

**Examples** :View1:Marker:SearchMax  
positions the marker on the highest signal on screen.

**Related Commands** :View<x>:Marker:SearchMin

**:View<x>:Marker:SearchMin (No Query Form)**

Positions the marker on the lowest signal on screen.

**Syntax** :View<x>:Marker:SearchMin

**Arguments** None

**Examples** :View1:Marker:SearchMin  
positions the marker on the lowest signal on screen.

**Related Commands** :View<x>:Marker:SearchMax

**:View<x>:Marker:SearchSeparation (?)**

Sets or queries the minimum horizontal distance to separate two peaks.

**Syntax** :View<x>:Marker:SearchSeparation <value>

**Arguments** <value>::=<NR2> specifies the minimum horizontal distance to separate two peaks. The range is 1 to 10 % relative to full-scale.

**Examples** :View1:Marker:SearchSeparation 10  
sets the minimum horizontal distance for peak separation to 10 % relative to full-scale.

**Related Commands** :View<x>:Scale:XScale

**:View<x>:Marker:X (?)**

Sets or queries the horizontal position of the marker.

**Syntax** :View<x>:Marker:X <value>

:View<x>:Marker:X?

**Arguments** <value>::=<NR1> ranges from the minimum (left) edge to the maximum (right) edge of the the horizontal axis (channel).

**Examples** :View1:Marker:X 32  
positions the marker at channel 32.

**Related Commands** :View<x>:Marker:Z



**:View<x>:Marker:Z (?)**

Sets or queries the marker position on the vertical (time slot number) axis.

**Syntax**    :View<x>:Marker:Z <value>  
              :View<x>:Marker:Z?

**Arguments** <value>::=<NR1> ranges 0 to the number of slots – 1.

**Examples**    :View1:Marker:Z 199  
              positions the marker at slot 199.

**Related Commands**    :View<x>:Marker:X

**:View<x>:Monochrome (?)**

Determines whether to display a spectrogram in monochrome.

**Syntax**    :View<x>:Monochrome { On | Off }  
              :View<x>:Monochrome?

**Arguments** On displays a spectrogram in monochrome.  
              Off displays a spectrogram in color.

**Examples**    :View1:Monochrome On  
              displays a spectrogram in monochrome.

## **:View<x>:NumberColors (?)**

Selects or queries the number of display colors.

**Syntax**     :View<x>:NumberColors { 10 | 100 }  
              :View<x>:NumberColors?

**Arguments**   10 selects the 10-color display.  
              100 selects the 100-color display (default).

**Examples**     :View1:NumberColors 100  
              selects the 100-color display.

**Related Commands**   :View<x>:Scale:YScale, :View<x>:Scale:YStart

## **:View<x>:Scale:AutoScale (No Query Form)**

Resets the Y (color) axis to the default setting.

**Syntax**     :View<x>:Scale:AutoScale

**Arguments**   None

**Examples**     :View1:Scale:AutoScale  
              resets the Y (color) axis to the default setting.

**Related Commands**   :View<x>:Scale:YScale

**:View<x>:Scale:XScale (?)**

Sets or queries the horizontal axis (channel) full-scale to display a portion of data.

**Syntax**    :View<x>:Scale:XScale <value>  
              :View<x>:Scale:XScale?

**Arguments** <value>::=<NR3> ranges 16 to 1024 channels.

**Examples**   :View1:Scale:XScale 64  
              sets the horizontal axis full-scale to 64 channels.

**Related Commands**   :View<x>:Scale:XStart, :View<x>:Scale:YScale, :View<x>:Scale:ZScale

**:View<x>:Scale:XStart (?)**

Sets or queries the value represented by the minimum (left) edge of the horizontal axis (channel).

**Syntax**    :View<x>:Scale:XStart <value>  
              :View<x>:Scale:XStart?

**Arguments** <value>::=<NR3> ranges from 0 to 1024 – (the horizontal axis full-scale) channels.

**Examples**   :View1:Scale:XStart 0  
              sets the value represented by the left edge of the horizontal axis to channel 0.

**Related Commands**   :View<x>:Scale:XScale

**:View<x>:Scale:YScale (?)**

Sets or queries the Y (color) axis full-scale to display a portion of the data.

**Syntax**     :View<x>:Scale:YScale <value>  
              :View<x>:Scale:YScale?

**Arguments**   <value>::=<NR3> is 10, 20, 50, or 100 dB.

**Examples**     :View1:Scale:YScale 50  
              sets the Y axis full-scale to 50 dB.

**Related Commands**   :View<x>:Scale:XScale, :View<x>:Scale:YStart, :View<x>:Scale:ZScale

**:View<x>:Scale:YStart (?)**

Sets or queries the value represented by the minimum (bottom) edge of the Y (color) axis.

**Syntax**     :View<x>:Scale:YStart <value>  
              :View<x>:Scale:YStart?

**Arguments**   <value>::=<NR3> ranges from ref level – 200 dB to ref level + 100 dB  
              – horizontal axis full-scale.

**Examples**     :View1:Scale:YStart -50  
              sets the value represented by the bottom edge of the Y axis to –50 dBm.

**Related Commands**   :View<x>:Scale:YScale

**:View<x>:Scale:ZScale (?)**

Sets or queries the time slot display interval. The spectrogram is displayed every specified number of slots.

**Syntax**    :View<x>:Scale:ZScale <value>  
               :View<x>:Scale:ZScale?

**Arguments**    <value>::=<NR1> ranges 1 to 32.  
                   1 means every slot is displayed. 32 means every 32<sup>th</sup> slot is displayed.

**Examples**     :View1:Scale:ZScale 8  
                   displays the spectrogram every 8<sup>th</sup> slot.

**Related Commands**    :View<x>:Scale:ZStart

**:View<x>:Scale:ZStart (?)**

Sets or queries the value represented by the minimum (bottom) edge of the Z (slot number) axis, i.e. the first slot to be displayed.

**Syntax**        :View<x>:Scale:ZStart <value>  
                   :View<x>:Scale:ZStart?

**Arguments**    <value>::=<NR1> ranges from 0 to the number of slots – 1.

**Examples**     :View1:Scale:ZStart 20  
                   sets the value represented by the bottom edge of the Z axis to 20.

**Related Commands**    :View<x>:Scale:ZScale

## **:View<x>:SymbolRate (?)**

Sets or queries the symbol rate to display the code-domain power.

**Syntax**     :View<x>:SymbolRate <value>

              :View<x>:SymbolRate?

**Arguments**   <value>::={ 1024k | 512k | 256k | 128k | 64k | 32k | 16k | Composite } selects the symbol rate. Composite corresponds to multi-rate.

**Examples**     :View1:SymbolRate 1024k  
                  sets the symbol rate to 1024K.

## **:View<x>:Version? (Query Only)**

Queries the version of the CodeWSpectrogram View program.

**Syntax**     :View<x>:Version?

**Returns**    <NR2>

**Examples**     :View1:Version?  
                  might return 1.1.

## **:View<x>:ZGap (?)**

Sets or queries the display interval between two adjacent time slots on the Z (slot number) axis on screen.

**Syntax**     :View<x>:ZGap <value>

              :View<x>:ZGap?

**Arguments**   <value>::=<NR1> ranges 1 to 10 pixels.

**Examples**     :View1:ZGap 10  
                  sets the display interval between two adjacent slots on the Z axis to 10 pixels.

## CodeWPolar View Commands (3086 Option 16 Only)

When you select CodeWPolar in the `:Config:View<x>` command, use the commands in this section to control the polar view. This view incorporates analysis functions for the W-CDMA standard.

For information on the polar view, refer to the *User Manual*.

**:View<x>:AlphaBT (?)**

Sets or queries the  $\alpha$ /BT value.

**Syntax**    :View<x>:AlphaBT <value>  
              :View<x>:AlphaBT?

**Arguments**   <value>::=<NR2> ranges 0.0001 to 1.

**Examples**    :View1:AlphaBT 1  
              sets the  $\alpha$ /BT value to 1.

**:View<x>:Analysis:TimeSlot (?)**

Specifies or queries the time slot number to display the constellation.

**Syntax**    :View<x>:Analysis:TimeSlot <value>  
              :View<x>:Analysis:TimeSlot?

**Arguments**   <value>::=<NR1> ranges 0 to the number of time slots -1.

**Examples**    :View1:Analysis:TimeSlot 1  
              sets the time slot number to 1.

**:View<x>:Analyze (No Query Form)**

Performs analysis on the background for all time slots acquired.

**Syntax**    :View<x>:Analyze

**Arguments**   None

**Examples**    :View1:Analyze  
              performs analysis for all slots.

**Related Commands**   :View<x>:BreakAnalyze



## **:View<x>:AutoCarrier (?)**

Determines whether to search the carrier automatically for each time slot.

**Syntax**    :View<x>:AutoCarrier { On | Off }  
              :View<x>:AutoCarrier?

**Arguments**    On searches the carrier automatically for each slot, and displays the frequency error in reference to the center frequency on screen at `Freq Error`.  
  
                  Off sets the carrier frequency to the value specified with the `:View<x>:Carrier` command.

**Examples**      :View1:AutoCarrier On  
                  searches the carrier automatically and displays the frequency error.

**Related Commands**    :View<x>:Carrier

## **:View<x>:BreakAnalyze (No Query Form)**

Breaks the analysis executed by the `:View<x>:Analyze` command.

**Syntax**        :View<x>:BreakAnalyze

**Arguments**    None

**Examples**      :View1:BreakAnalyze  
                  breaks the analysis.

**Related Commands**    :View<x>:Analyze

**:View<x>:Carrier (?)**

Sets or queries the carrier frequency.

**Syntax**     :View<x>:Carrier <value>  
              :View<x>:Carrier?

**Arguments**   <value>::=<NR3> ranges 0 Hz to 3 GHz.

**Examples**     :View1:Carrier 1.2G  
                  sets the carrier frequency to 1.2 GHz.

**Related Commands**   :View<x>:AutoCarrier

**:View<x>:Display (?)**

Selects or queries the display data source.

**Syntax**     :View<x>:Display { Measurement | Reference }  
              :View<x>:Display?

**Arguments**   Measurement displays the measurement data.  
  
              Reference displays the reference data. Only the symbol constellation can be displayed.  
  
              Refer to the *User Manual* on the measurement and reference data.

**Examples**     :View1:Display Measurement  
                  displays the measurement data.

**Related Commands**   :View<x>:MeasFilter, :View<x>:RefFilter

**:View<x>:Format (?)**

Selects or queries the waveform display format.

**Syntax**    :View<x>:Format { Vector | Constellation }  
              :View<x>:Format?

**Arguments**    Vector selects the Vector format. It displays symbol-to-symbol movements using vector.

                  Constellation selects the Constellation format. It displays only symbols.

**Examples**     :View1:Format Vector  
                  selects the Vector display format.

**:View<x>:Marker:T (?)**

Sets or queries the marker position on the time axis.

**Syntax**     :View<x>:Marker:T <value>  
              :View<x>:Marker:T?

**Arguments**    <value>::=<NR3> ranges from 0 to the time length of the acquisition data.

**Examples**     :View1:Marker:T 5.4u  
                  positions the marker at 5.4  $\mu$ s.

**:View<x>:MeasFilter (?)**

Selects or queries the filter to create the measurement data.

**Syntax**    :View<x>:MeasFilter { None | RootRaisedCosine }  
              :View<x>:MeasFilter?

**Arguments**    None selects no filter.  
                  RootRaisedCosine selects the root raised-cosine filter.

**Examples**     :View1:MeasFilter RootRaisedCosine  
                  selects the root raised-cosine filter to create the measurement data.

**Related Commands**    :View<x>:RefFilter

**:View<x>:Modulation (?)**

Selects or queries the modulation type.

**Syntax**        :View<x>:Modulation W-CDMA  
                  :View<x>:Modulation?

**Arguments**    W-CDMA selects the W-CDMA modulation (this parameter only).

**Examples**     :View1:Modulation W-CDMA  
                  selects the W-CDMA modulation.

**:View<x>:RefFilter (?)**

Selects or queries the filter to create the reference data.

**Syntax** :View<x>:RefFilter { None | RaisedCosine | Gaussian }  
:View<x>:RefFilter?

**Arguments** None selects no filter.  
RaisedCosine selects the raised cosine filter.  
Gaussian selects the Gaussian filter.

**Examples** :View1:RefFilter RaisedCosine  
selects the raised cosine filter to create the reference data.

**Related Commands** :View<x>:MeasFilter

**:View<x>:ShortCode (?)**

Sets or queries the short code number to display the symbol constellation.

**Syntax** :View<x>:ShortCode <value>  
:View<x>:ShortCode?

**Arguments** <value>::=<NR1> ranges 0 to 1023 of the channel number.

**Examples** :View1:ShortCode 255  
sets the short code to channel 255.

**Related Commands** :View<x>:SymbolConstellation

## **:View<x>:Source (?)**

Selects or queries the display data source.

**Syntax**    :View<x>:Source { None | Active | Zoom | <file\_name> }  
              :View<x>:Source?

**Arguments**   None specifies no source. The display area in the view will be emptied.  
              Active specifies the currently acquired data as the source.  
              Zoom specifies the zoomed data as the source.  
              <file\_name>::=<string> specifies the data file as the source. The file name must be “\*.IQ” (the IQ format).

**Examples**    :View1:Source Active  
              specifies the currently acquired data as the source.

## **:View<x>:Standard:WCDMA16M (No Query Form)**

Configures the modulating system according to the W-CDMA standard with the chip rate of 16 M.

**Syntax**    :View<x>:Standard:WCDMA16M

**Arguments**   None

**Examples**    :View1:Standard:WCDMA16M  
              configures the modulating system according to the W-CDMA standard with the chip rate of 16 M.

**Related Commands**   :View<x>:Standard:WCDMA4M, :View<x>:Standard:WCDMA8M

## **:View<x>:Standard:WCDMA4M (No Query Form)**

Configures the modulating system according to the W-CDMA standard with the chip rate of 4 M.

**Syntax**    :View<x>:Standard:WCDMA4M

**Arguments** None

**Examples** :View1:Standard:WCDMA4M  
configures the modulating system according to the W-CDMA standard with the chip rate of 4 M.

**Related Commands** :View<x>:Standard:WCDMA16M, :View<x>:Standard:WCDMA8M

### **:View<x>:Standard:WCDMA8M (No Query Form)**

Configures the modulating system according to the W-CDMA standard with the chip rate of 4 M.

**Syntax** :View<x>:Standard:WCDMA8M

**Arguments** None

**Examples** :View1:Standard:WCDMA8M  
configures the modulating system according to the W-CDMA standard with the chip rate of 8 M.

**Related Commands** :View<x>:Standard:WCDMA16M, :View<x>:Standard:WCDMA4M

### **:View<x>:SymbolConstellation (?)**

Determines whether or not to display the symbol constellation.

**Syntax** :View<x>:SymbolConstellation { On | Off }  
:View<x>:SymbolConstellation?

**Arguments** On displays the symbol constellation.  
Off does not display the symbol constellation.

**Examples** :View1:SymbolConstellation On  
displays the symbol constellation.

**Related Commands** :View<x>:ShortCode, :View<x>:TimeSlot

## **:View<x>:SymbolRate (?)**

Sets or queries the symbol rate.

**Syntax**     :View<x>:SymbolRate <value>  
              :View<x>:SymbolRate?

**Arguments**   <value>::={ 4M | 8M | 16M } selects the symbol rate.

**Examples**     :View1:SymbolRate 4M  
              sets the symbol rate to 4 M/s.

## **:View<x>:TimeSlot (?)**

Specifies or queries the time slot number to display the symbol constellation.

**Syntax**     :View<x>:TimeSlot <value>  
              :View<x>:TimeSlot?

**Arguments**   <value>::=<NR1> ranges from 0 to the number of time slots –1.

**Examples**     :View1:TimeSlot 1  
              sets the slot number to 1.

**Related Commands**   :View<x>:SymbolConstellation

## **:View<x>:Version? (Query Only)**

Queries the version of the CodeWPolar View program.

**Syntax**     :View<x>:Version?

**Returns**    <NR2>

**Examples**     :View1:Version?  
              might return 1.1.



## CodeWPower View Commands (3086 Option16 Only)

When you select CodeWPower in the `Config:View<x>` command, use the commands in this section to set the details for the code-domain power view. This view incorporates analysis functions for the W-CDMA standard.

**:View<x>:Average (?)**

Determines whether or not to display the results of averaging on the analyzer screen.

**Syntax**     :View<x>:Average { On | Off }  
              :View<x>:Average?

**Arguments**   On displays the results of averaging. The averaged power is displayed for each channel or symbol with a bar graph.  
              Off hides the results of averaging.

**Examples**     :View1:Average On  
                  displays the results of averaging.

**Related Commands**   :View<x>:Average:Execute

**:View<x>:Average:AllFrames (No Query Form)**

Specifies that all of the acquired time slots are used for averaging.

**Syntax**     :View<x>:Average:AllFrames

**Arguments**   None

**Examples**     :View1:Average:AllFrames  
                  specifies that all of the acquired time slots are used for averaging.

**Related Commands**   :View<x>:Average:BeginZ, :View<x>:Average:EndZ

**:View<x>:Average:BeginZ (?)**

Specifies or queries the uppermost time slot in the average range.

**Syntax**    :View<x>:Average:BeginZ <value>  
              :View<x>:Average:BeginZ?

**Arguments**    <value>::=<NR1> ranges from 0 to the number of slots – 1.

**Examples**     :View1:Average:BeginZ 199  
                  sets the uppermost slot number to 199.

**Related Commands**    :View<x>:Average:EndZ

**:View<x>:Average:EndZ (?)**

Specifies or queries the lowermost time slot in the average range.

**Syntax**    :View<x>:Average:EndZ <value>  
              :View<x>:Average:EndZ?

**Arguments**    <value>::=<NR1> ranges from 0 to the number of slots – 1.

**Examples**     :View1:Average:EndZ 100  
                  sets the lowermost slot number to 100.

**Related Commands**    :View<x>:Average:BeginZ

## **:View<x>:Average:Execute (No Query Form)**

Performs averaging for each bin for the time slots in the specified range.

**Syntax** :View<x>:Average:Execute

**Arguments** None

**Examples** :View1:Average:Execute  
performs averaging for each bin for the time slots in the specified range.

**Related Commands** :View<x>:Average:AllFrames, :View<x>:Average:BeginZ,  
:View<x>:Average:EndZ

## **:View<x>:Average:MarkerToFrame (No Query Form)**

Specifies that the time slots between the main marker and the delta marker are averaged.

**Syntax** :View<x>:Average:MarkerToFrame

**Arguments** None

**Examples** :View<x>:Average:MarkerToFrame  
specifies that the time slots between the main marker and the delta marker are averaged.

**Related Commands** :View<x>:Average:BeginZ, :View<x>:Average:EndZ

**:View<x>:Average:Times (?)**

Sets or queries the number of waveform acquisitions that make up an averaged waveform.

**Syntax**    :View<x>:Average:Times <value>  
:View<x>:Average:Times?

**Arguments**    <value>::=<NR1> ranges 1 to 1,000,000.

**Examples**    :View1:Average:Times 1000  
specifies that an averaged waveform will show the result of combining 1000 waveforms.

**Related Commands**    :View<x>:Average:Type

**:View<x>:Average:Type (?)**

Selects or queries the average type. You can also select the peak hold mode. For more information about the averaging, refer to the *User Manual*.

**Syntax**    :View<x>:Average:Type { RMSExpo | RMS | MaxHold | MinHold }  
:View<x>:Average:Type?

**Arguments**    RMSExpo averages with the RMS (root mean squared) exponential. This mode weights older acquisition data so that they have a progressively smaller effect on the average.

RMS averages with the RMS (root mean squared).

MaxHold holds the maximum value for each data point.

MinHold holds the minimum value for each data point.

**Examples**    :View1:Average:Type RMSExpo  
averages waveform with the exponential RMS.

**Related Commands**    :View<x>:Average:Time

**:View<x>:Marker:DeltaMarker (?)**

Turns the delta marker on or off.

**Syntax**    :View<x>:Marker:DeltaMarker { On | Off }  
              :View<x>:Marker:DeltaMarker?

**Arguments**    On turns the delta marker on.  
                  Off turns the delta marker off.

**Examples**     :View1:Marker:DeltaMarker On  
                  turns the delta marker on.

**Related Commands**    :View<x>:Marker:ResetDelta

**:View<x>:Marker:ResetDelta (No Query Form)**

Moves the delta marker to the main marker position.

**Syntax**        :View<x>:Marker:ResetDelta

**Arguments**    None

**Examples**     :View1:Marker:ResetDelta  
                  moves the delta marker to the main marker position.

**Related Commands**    :View<x>:Marker:DeltaMarker

**:View<x>:Marker:SearchMax (No Query Form)**

Positions the marker on the highest signal on screen.

**Syntax**        :View<x>:Marker:SearchMax

**Arguments**    None

**Examples** :View1:Marker:SearchMax  
positions the marker on the highest signal on screen.

**Related Commands** :View<x>:Marker:SearchMin

### **:View<x>:Marker:SearchMin (No Query Form)**

Positions the marker on the lowest signal on screen.

**Syntax** :View<x>:Marker:SearchMin

**Arguments** None

**Examples** :View1:Marker:SearchMin  
positions the marker on the lowest signal on screen.

**Related Commands** :View<x>:Marker:SearchMax

### **:View<x>:Marker:SearchSeparation (?)**

Sets or queries the minimum horizontal distance to separate two peaks.

**Syntax** :View<x>:Marker:SearchSeparation <value>

**Arguments** <value>::=<NR2> specifies the minimum horizontal distance to separate two peaks. The range is 1 to 10 % relative to full-scale.

**Examples** :View1:Marker:SearchSeparation 10  
sets the minimum horizontal distance for peak separation to 10 % relative to full-scale.

**Related Commands** :View<x>:Scale:XScale

**:View<x>:Marker:X (?)**

Sets or queries the horizontal position of the marker.

**Syntax**    :View<x>:Marker:X <value>  
              :View<x>:Marker:X?

**Arguments**   <value>::=<NR1> ranges from the minimum (left) edge to the maximum (right) edge of the the horizontal axis (channel or symbol).

**Examples**    :View1:Marker:X 32  
              positions the marker at channel 32.

**Related Commands**   :View<x>:Scale:XScale, :View<x>:Scale:XStart

**:View<x>:Scale:AutoScale (No Query Form)**

Resets the vertical axis (power) to the default setting.

**Syntax**    :View<x>:Scale:AutoScale

**Arguments**   None

**Examples**    :View1:Scale:AutoScale  
              resets the vertical axis to the default setting.

**Related Commands**   :View<x>:Scale:YScale



**:View<x>:Scale:XScale (?)**

Sets or queries the horizontal axis (channel or symbol) full-scale to display a portion of data.

**Syntax** :View<x>:Scale:XScale <value>  
:View<x>:Scale:XScale?

**Arguments** <value>::=<NR1> depends on the horizontal axis setting:

Horizontal axis	Value
Short code	16, 32, 64, 128, 256, 512, or 1024
Symbol	20, 40, 80, 160, 320, or 640

**Examples** :View1:Scale:XScale 64  
sets the horizontal axis full-scale to 64 channels.

**Related Commands** :View<x>:Scale:XStart, :View<x>:Scale:YScale, :View<x>:XAxis

**:View<x>:Scale:XStart (?)**

Sets or queries the value represented by the minimum (left) edge of the horizontal axis (channel or symbol).

**Syntax** :View<x>:Scale:XStart <value>  
:View<x>:Scale:XStart?

**Arguments** <value>::=<NR1> ranges from 0 to 1024 – (the horizontal axis full-scale) channels.

**Examples** :View1:Scale:XStart 0  
sets the value represented by the left edge of the horizontal axis to 0.

**Related Commands** :View<x>:Scale:XScale

**:View<x>:Scale:YScale (?)**

Sets or queries the vertical axis (power) full-scale to display a portion of the data.

**Syntax**     :View<x>:Scale:YScale <value>  
              :View<x>:Scale:YScale?

**Arguments**   <value>::=<NR3> ranges 1 to 100 dB.

**Examples**     :View1:Scale:YScale 50  
              sets the vertical axis full-scale to 50 dB.

**Related Commands**   :View<x>:Scale:XScale, :View<x>:Scale:YStart

**:View<x>:Scale:YStart (?)**

Sets or queries the value represented by the minimum (bottom) edge of the vertical axis (power).

**Syntax**     :View<x>:Scale:YStart <value>  
              :View<x>:Scale:YStart?

**Arguments**   <value>::=<NR3> ranges from ref level – 200 dB to ref level + 100 dB  
              – horizontal axis full-scale.

**Examples**     :View1:Scale:YStart -50  
              sets the value represented by the bottom edge of the vertical axis to –50 dB.

**Related Commands**   :View<x>:Scale:YScale

**:View<x>:ShortCode (?)**

Specifies or queries the short code to display the code-domain power when the horizontal axis represents symbol.

**Syntax** :View<x>:ShortCode <value>  
:View<x>:ShortCode?

**Arguments** <value>::=<NR1> ranges 0 to 1023 of the channel number.

**Examples** :View1:ShortCode 255  
sets the short code to channel 255.

**Related Commands** :View<x>:XAxis

## :View<x>:SymbolRate (?)

Sets or queries the symbol rate to display the code-domain power.

**Syntax** :View<x>:SymbolRate <value>  
:View<x>:SymbolRate?

**Arguments** <value>::={ 1024k | 512k | 256k | 128k | 64k | 32k | 16k | Composite } selects the symbol rate. Composite corresponds to multi-rate.

**Examples** :View1:SymbolRate 1024k  
sets the symbol rate to 1024K.

## :View<x>:Version? (Query Only)

Queries the version of the CodeWPower View program.

**Syntax** :View<x>:Version?

**Returns** <NR2>

**Examples** :View1:Version?  
might return 1.1.

**:View<x>:XAxis (?)**

Specifies or queries the horizontal axis.

**Syntax**     :View<x>:XAxis { ShortCode | Symbol }  
              :View<x>:XAxis?

**Arguments**   ShortCode defines the horizontal axis as short code.  
              Symbol defines the horizontal axis as symbol.

**Examples**     :View1:XAxis ShortCode  
              defines the horizontal axis as short code.

**Related Commands**   :View<x>:ShortCode

**:View<x>:Z (?)**

Specifies or queries the displayed time slot number.

**Syntax**     :View<x>:Z <value>  
              :View<x>:Z?

**Arguments**   <value>::=<NR1> ranges from 0 to the number of slots – 1.

**Examples**     :View1:Z 199  
              specifies that the slot 199 displays.

## CCDF Commands (Option 20 Only)

When you select CCDF in the `Config:View<x>` command, use the commands in this section to set details for the CCDF (Complementary Cumulative Distribution Function) measurement. The final results are displayed on CCDFView, which is controlled with the CCDFView commands (refer to page 2–347).

For details on the CCDF measurement, refer to the *User Manual*.

**:View<x>:AllFrames (No Query Form)**

Specifies that CCDF is calculated for data in all frames acquired.

**Syntax** :View<x>:AllFrames

**Arguments** None

**Examples** :View1:AllFrames  
specifies that CCDF is calculated for data in all frames.

**Related Commands** :View<x>:BeginZ, :View<x>:EndZ

**:View<x>:Average:Reset (No Query Form)**

Stops the current CCDF measurement and restarts the process.

**Syntax** :View<x>:Average:Reset

**Arguments** None

**Examples** :View1:Average:Reset  
stops the current CCDF measurement and restarts the process.

**Related Commands** :View<x>:Execute

**:View<x>:BeginZ (?)**

Specifies or queries the uppermost frame in the CCDF calculation range.

**Syntax** :View<x>:BeginZ <value>  
:View<x>:BeginZ?

**Arguments** <value>::=<NR1> ranges from 0 to the number of frames – 1.

**Examples** :View1:BeginZ 199  
sets the uppermost frame number to 199.

**Related Commands** :View<x>:EndZ

**:View<x>:Destination (?)**

Selects or queries the destination to output the CCDF calculation results.

**Syntax** :View<x>:Destination { D1 | D2 | D3 | D4 | D5 | D6 | D7 | D8 }  
:View<x>:Destination?

**Arguments** D1 to D8 selects one of the data registers to output the CCDF calculation results.

**Examples** :View1:Destination D1  
selects the D1 data register.

**:View<x>:EndZ (?)**

Specifies or queries the lowermost frame in the CCDF calculation range.

**Syntax**    :View<x>:EndZ <value>  
              :View<x>:EndZ?

**Arguments**   <value>::=<NR1> ranges from 0 to the number of frames – 1.

**Examples**    :View1:EndZ 100  
              sets the lowermost frame number to 100.

**Related Commands**   :View<x>:BeginZ

**:View<x>:Execute (No Query Form)**

Performs the CCDF calculation.

**Syntax**    :View<x>:Execute

**Arguments**   None

**Examples**    :View1:Execute  
              performs the CCDF calculation.

**Related Commands**   :View<x>:Average:Reset



**:View<x>:Marker:DeltaMarker (?)**

Turns the delta marker on or off.

**Syntax** :View<x>:Marker:DeltaMarker { On | Off }  
:View<x>:Marker:DeltaMarker?

**Arguments** On turns the delta marker on.  
Off turns the delta marker off.

**Examples** :View1:Marker:DeltaMarker On  
turns the delta marker on.

**Related Commands** :View<x>:Marker:ResetDelta

**:View<x>:Marker:ResetDelta (No Query Form)**

Moves the delta marker to the main marker position.

**Syntax** :View<x>:Marker:ResetDelta

**Arguments** None

**Examples** :View1:Marker:ResetDelta  
moves the delta marker to the main marker position.

**Related Commands** :View<x>:Marker:DeltaMarker

## **:View<x>:Marker:SearchMax (No Query Form)**

Positions the marker on the highest signal on screen.

**Syntax**     :View<x>:Marker:SearchMax

**Arguments**   None

**Examples**     :View1:Marker:SearchMax  
positions the marker on the highest signal on screen.

**Related Commands**   :View<x>:Marker:SearchMin

## **:View<x>:Marker:SearchMin (No Query Form)**

Positions the marker on the lowest signal on screen.

**Syntax**     :View<x>:Marker:SearchMin

**Arguments**   None

**Examples**     :View1:Marker:SearchMin  
positions the marker on the lowest signal on screen.

**Related Commands**   :View<x>:Marker:SearchMax

**:View<x>:Marker:SearchSeparation (?)**

Sets or queries the minimum horizontal distance to separate two peaks.

**Syntax** :View<x>:Marker:SearchSeparation <value>

**Arguments** <value>::=<NR2> specifies the minimum horizontal distance to separate two peaks. The range is 1 to 10 % relative to full-scale.

**Examples** :View1:Marker:SearchSeparation 10  
sets the minimum horizontal distance for peak separation to 10 % relative to full-scale.

**Related Commands** :View<x>:Scale:XScale

**:View<x>:Marker:X (?)**

Sets or queries the horizontal position of the marker.

**Syntax** :View<x>:Marker:X <value>

:View<x>:Marker:X?

**Arguments** <value>::=<NR3> ranges from the minimum (left) edge to the maximum (right) edge of the the horizontal (time) axis.

**Examples** :View1:Marker:X 20u  
positions the marker at -20  $\mu$ s.

**Related Commands** :View<x>:Scale:XScale, :View<x>:Scale:XStart,  
:View<x>:Scale:XStartZero

**:View<x>:MarkerToFrame (No Query Form)**

Specifies that CCDF is calculated for the range between the main marker and the delta marker.

**Syntax** :View<x>:MarkerToFrame

**Arguments** None

**Examples** :View1:MarkerToFrame  
specifies that CCDF is calculated for the range between the main marker and the delta marker.

**Related Commands** :View<x>:AllFrames, :View<x>:BeginZ, :View<x>:EndZ

**:View<x>:OutputFormat (?)**

Selects or queries the display format of the CCDF calculation results.

**Syntax** :View<x>:OutputFormat { CCDF | Histogram }  
:View<x>:OutputFormat?

**Arguments** CCDF specifies that the CCDF calculation results are displayed with time along the horizontal axis and power along the vertical axis.

Histogram transforms the CCDF calculation results to a histogram.

**Examples** :View1:OutputFormat CCDF  
selects the CCDF format.

## **:View<x>:Position (?)**

Specifies or queries which frame in a block to be displayed.

**Syntax**    :View<x>:Position <value>  
              :View<x>:Position?

**Arguments**   <value>::=<NR2> ranges 0 to 100 %. It specifies the display frame position relative to the block size. 0 % specifies that the first frame in a block is displayed. 100 % represents the last frame.

**Examples**    :View1:Position 100  
              displays the last frame in a block.

## **:View<x>:Resolution (?)**

Sets or queries the amplitude resolution of a histogram when the output format is set to Histogram with the :View<x>:OutputFormat command.

**Syntax**    :View<x>:Resolution <value>  
              :View<x>:Resolution?

**Arguments**   <value>::=<NR3> ranges 0.01 to 10 dB.

**Examples**    :View1:Resolution 10  
              sets the resolution of a histogram to 10 dB.

**Related Commands**   :View<x>:OutputFormat

**:View<x>:Result1? (Query Only)**

Queries the crest factor (the maximum – average of amplitude).

**Syntax** :View<x>:Result1?

**Returns** <NR3>

**Examples** :View1:Result1?  
might return 11.916, indicating that the crest factor is 11.916 dB.

**Related Commands** :View<x>:Result2?, :View<x>:Result3?

**:View<x>:Result2? (Query Only)**

Queries the maximum amplitude.

**Syntax** :View<x>:Result2?

**Returns** <NR3>

**Examples** :View1:Result2?  
might return -1.446, indicating that the maximum amplitude is -1.446 dBm.

**Related Commands** :View<x>:Result1?, :View<x>:Result3?

**:View<x>:Result3? (Query Only)**

Queries the average amplitude.

**Syntax** :View<x>:Result3?

**Returns** <NR3>

**Examples** :View1:Result3?  
might return -13.363, indicating that the average amplitude is -13.363 dBm.

**Related Commands** :View<x>:Result1?, :View<x>:Result2?

**:View<x>:Scale:AutoScale (No Query Form)**

Resets the vertical axis (amplitude) to full-scale.

**Syntax** :View<x>:Scale:AutoScale

**Arguments** None

**Examples** :View1:Scale:AutoScale  
resets the vertical axis to full-scale.

**Related Commands** :View<x>:Scale:YScale

**:View<x>:Scale:HoldYScale (?)**

Determines whether to hold or reset the vertical scale when you change the input source.

**Syntax**     :View<x>:Scale:HoldYScale { On | Off }  
              :View<x>:Scale:HoldYScale?

**Arguments**   On holds the vertical scale setting when you change the input source.  
              Off resets the vertical scale to full-scale.

**Examples**     :View1:Scale:HoldYScale On  
              holds the vertical scale setting when you change the input source.

**Related Commands**   :View<x>:Scale:YScale, :View<x>:Scale:YStart, :View<x>:Source

**:View<x>:Scale:Origin (No Query Form)**

Resets the horizontal and vertical axis scale to the default setting.

**Syntax**     :View<x>:Scale:Origin

**Arguments**   None

**Examples**     :View1:Scale:Origin  
              resets the horizontal and vertical axis scale to the default setting.

**Related Commands**   :View<x>:Scale:XScale, :View<x>:Scale:YScale



**:View<x>:Scale:XScale (?)**

Sets or queries the horizontal (time) axis full-scale to display a portion of data.

**Syntax**    :View<x>:Scale:XScale <value>  
               :View<x>:Scale:XScale?

**Arguments**    <value>::=<NR3> ranges from (time length of a frame)/256 to (time length of a frame).

**Examples**     :View1:Scale:XScale 50u  
                   sets the horizontal axis full-scale to 50  $\mu$ s.

**Related Commands**    :View<x>:Scale:XStart, :View<x>:Scale:YScale

**:View<x>:Scale:XStart (?)**

Sets or queries the value represented by the minimum (left) edge of the horizontal (time) axis.

**Syntax**    :View<x>:Scale:XStart <value>  
               :View<x>:Scale:XStart?

**Arguments**    <value>::=<NR3> ranges from the minimum to the maximum time of acquired data – the horizontal axis full-scale setting.

**Examples**     :View1:Scale:XStart -50  
                   sets the value represented by the left edge of the horizontal axis to -50  $\mu$ s.

**Related Commands**    :View<x>:Scale:XScale, :View<x>:Scale:XStartZero

**:View<x>:Scale:XStartZero (?)**

Determines whether to put the time at the left edge of each frame to zero.

**Syntax** :View<x>:Scale:XStartZero { On | Off }  
:View<x>:Scale:XStartZero?

**Arguments** On puts the time at the left edge of each frame to zero.  
Off uses the normal time axis.

The difference between On and Off is illustrated in Figure 2–10 below.

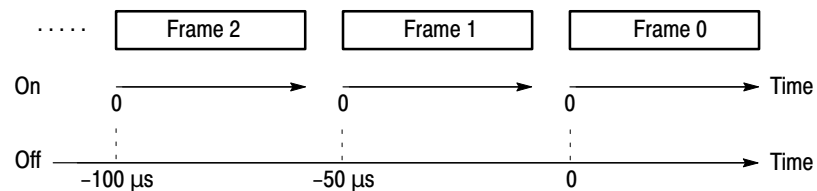

**Figure 2-10: :View<x>:Scale:XStartZero On and Off (example)**

**Examples** :View1:Scale:XStartZero On  
puts the time at the left edge of each frame to zero.

**Related Commands** :View<x>:Scale:XStart

**:View<x>:Scale:YScale (?)**

Sets or queries the vertical axis (amplitude) full-scale to display a portion of data.

**Syntax** :View<x>:Scale:YScale <value>  
:View<x>:Scale:YScale?

**Arguments** <value>::=<NR3> ranges from full-scale/100 to full-scale of acquired data.

**Examples** :View1:Scale:YScale 100  
sets the vertical axis full-scale to 100 dB.

**Related Commands** :View<x>:Scale:XScale, :View<x>:Scale:YStart

## :View<x>:Scale:YStart (?)

Sets or queries the value represented by the minimum (bottom) edge of the vertical axis (amplitude).

**Syntax** :View<x>:Scale:YStart <value>

:View<x>:Scale:YStart?

**Arguments** <value>::=<NR3> ranges from the minimum of acquired data to the maximum – full-scale setting.

**Examples** :View1:Scale:YStart -90  
sets the value represented by the bottom edge of the vertical axis to -90 dBm.

**Related Commands** :View<x>:Scale:YScale

## :View<x>:Source (?)

Selects or queries the data source for the view.

**Syntax** :View<x>:Source { None | Active | Zoom | <file\_name> }

:View<x>:Source?

**Arguments** None specifies no source. The display area in the view will be emptied.

Active specifies the currently acquired data as the source.

Zoom specifies the zoomed data as the source.

<file\_name>::=<string> specifies the file as the source. The file name must be “\*.IQ” (the IQ format).

**Examples** :View1:Source Active  
specifies the currently acquired data as the view source.

**:View<x>:Version? (Query Only)**

Queries the version of the CCDF program.

**Syntax**     :View<x>:Version?

**Returns**    <NR2>

**Examples**   :View1:Version?  
              might return 1.1.

**:View<x>:Z (?)**

Specifies or queries the displayed frame number.

**Syntax**     :View<x>:Z <value>

              :View<x>:Z?

**Arguments** <value>::=<NR1> ranges from 0 to the number of frames – 1.

**Examples**   :View1:Z 199  
              specifies that the frame 199 displays.

## CCDFView Commands (Option 20 Only)

When you select `CCDFView` in the `Config:View<x>` command, use the commands in this section to set details for the CCDF (Complementary Cumulative Distribution Function) view. This view displays the final results of CCDF measurement, which is controlled with the CCDF commands (refer to page 2–331).

For details on the CCDF measurement, refer to the *User Manual*.

## :View<x>:CopyFrom (No Query Form)

Copies display data from a data register or text file to the data register specified with the :View<x>:Source command.

**Syntax** :View<x>:CopyFrom { D1 | D2 | D3 | D4 | D5 | D6 | D7 | D8 | <file\_name> }

**Arguments** D1 to D8 selects one of the data registers.  
<file\_name>::=<string> is “\*.TXT” (ASCII text file).

The register or file is the one to which the display data has been stored with the :View<x>:CopyTo command. The data of the register or file is copied to the register specified with the :View<x>:Source command.

**Examples** :View1:CopyFrom D2  
copies display data from the data register D2.

**Related Commands** :View<x>:CopyTo, :View<x>:Source

## :View<x>:CopyTo (No Query Form)

Stores the display data to a file or data register. This command is effective only for the data acquired in the Vector mode.

**Syntax** :View<x>:CopyTo { Clipboard | D1 | D2 | D3 | D4 | D5 | D6 | D7 | D8 | <file\_name> }

**Arguments** Clipboard copies the display data to the Windows clipboard in the ASCII text format. You can use the data in your application.

D1 to D8 are the data register 1 to 8, respectively.

<file\_name>::=<string> is “\*.TXT” (ASCII text file). The extension is set to “.TXT” automatically.

**Examples** :View1:CopyTo Clipboard  
stores the display data to the clipboard.

**Related Commands** :View<x>:CopyFrom

**:View<x>:Marker:DeltaMarker (?)**

Turns the delta marker on or off.

**Syntax** :View<x>:Marker:DeltaMarker { On | Off }  
:View<x>:Marker:DeltaMarker?

**Arguments** On turns the delta marker on.  
Off turns the delta marker off.

**Examples** :View1:Marker:DeltaMarker On  
turns the delta marker on.

**Related Commands** :View<x>:Marker:ResetDelta

**:View<x>:Marker:ResetDelta (No Query Form)**

Moves the delta marker to the main marker position.

**Syntax** :View<x>:Marker:ResetDelta

**Arguments** None

**Examples** :View1:Marker:ResetDelta  
moves the delta marker to the main marker position.

**Related Commands** :View<x>:Marker:DeltaMarker

## **:View<x>:Marker:SearchMax (No Query Form)**

Positions the marker on the highest signal on screen.

**Syntax**      :View<x>:Marker:SearchMax

**Arguments**    None

**Examples**      :View1:Marker:SearchMax  
positions the marker on the highest signal on screen.

**Related Commands**    :View<x>:Marker:SearchMin

## **:View<x>:Marker:SearchMin (No Query Form)**

Positions the marker on the lowest signal on screen.

**Syntax**      :View<x>:Marker:SearchMin

**Arguments**    None

**Examples**      :View1:Marker:SearchMin  
positions the marker on the lowest signal on screen.

**Related Commands**    :View<x>:Marker:SearchMax



**:View<x>:Marker:SearchSeparation (?)**

Sets or queries the minimum horizontal distance to separate two peaks.

**Syntax** :View<x>:Marker:SearchSeparation <value>

**Arguments** <value>::=<NR2> specifies the minimum horizontal distance to separate two peaks. The range is 1 to 10 % relative to full-scale.

**Examples** :View1:Marker:SearchSeparation 10  
sets the minimum horizontal distance for peak separation to 10 % relative to full-scale.

**Related Commands** :View<x>:Scale:XScale

**:View<x>:Marker:X (?)**

Sets or queries the horizontal position of the marker.

**Syntax** :View<x>:Marker:X <value>

:View<x>:Marker:X?

**Arguments** <value>::=<NR3> ranges from the minimum (left) edge to the maximum (right) edge of the the horizontal axis (amplitude).

**Examples** :View1:Marker:X 5  
positions the marker at 5 dB.

**Related Commands** :View<x>:Scale:XScale, :View<x>:Scale:XStart

**:View<x>:Scale:AutoScale (No Query Form)**

Adjusts scaling of the vertical axis automatically to best display the data.

**Syntax** :View<x>:Scale:AutoScale

**Arguments** None

**Examples** :View1:Scale:AutoScale  
adjusts scaling of the vertical axis automatically to best display the data.

**Related Commands** :View<x>:Scale:YScale

**:View<x>:Scale:LYStart (?)**

Sets or queries the value represented by the minimum (bottom) edge of the vertical axis (CCDF).

**Syntax** :View<x>:Scale:LYStart <value>

:View<x>:Scale:LYStart?

**Arguments** <value>::=<NR3> ranges 1/10<sup>8</sup> to 100 %.

The value must be smaller than the one set with the :View<x>:Scale:LYStop command.

**Examples** :View1:Scale:LYStart 1m  
sets the value represented by the bottom edge of the vertical axis to 1/1000 %.

**Related Commands** :View<x>:Scale:LYStop

**:View<x>:Scale:LYStop (?)**

Sets or queries the value represented by the maximum (top) edge of the vertical axis (CCDF).

**Syntax**    :View<x>:Scale:LYStop <value>  
               :View<x>:Scale:LYStop?

**Arguments**    <value>::=<NR3> ranges 1/10<sup>8</sup> to 100 %.

The value must be greater than the one set with the :View<x>:Scale:LYStart command.

**Examples**        :View1:Scale:LYStop 100  
                       sets the value represented by the top edge of the vertical axis to 100 %.

**Related Commands**    :View<x>:Scale:LYStart

**:View<x>:Scale:Origin (No Query Form)**

Resets the horizontal and vertical scale to the default setting.

**Syntax**        :View<x>:Scale:Origin

**Arguments**    None

**Examples**        :View1:Scale:Origin  
                       resets the horizontal and vertical scale to the default setting.

**Related Commands**    :View<x>:Scale:LYStart, :View<x>:Scale:LYStop,  
                           :View<x>:Scale:XScale

**:View<x>:Scale:XScale (?)**

Sets or queries the horizontal axis (amplitude) full-scale to display a portion of data.

**Syntax**     :View<x>:Scale:XScale <value>  
              :View<x>:Scale:XScale?

**Arguments**   <value>::=<NR3> ranges full-scale/256 to full-scale of the acquired data.

**Examples**     :View1:Scale:XScale 10  
              sets the horizontal axis full-scale to 10 dB.

**Related Commands**   :View<x>:Scale:LYStart, :View<x>:Scale:LYStop,  
                      :View<x>:Scale:XStart

**:View<x>:Scale:XStart (?)**

Sets or queries the value represented by the minimum (left) edge of the horizontal axis (amplitude).

**Syntax**     :View<x>:Scale:XStart <value>  
              :View<x>:Scale:XStart?

**Arguments**   <value>::=<NR3> ranges from the minimum to the maximum amplitude of acquired data – the horizontal axis full-scale setting.

**Examples**     :View1:Scale:XStart 0  
              sets the value represented by the left edge of the horizontal axis to 0 dB.

**Related Commands**   :View<x>:Scale:XScale

**:View<x>:Source (?)**

Selects or queries the data source for the view.

**Syntax** :View<x>:Source { None | D1 | D2 | D3 | D4 | D5 | D6 | D7 | D8 }  
:View<x>:Source?

**Arguments** None specifies no source. The display area in the view will be emptied.  
D1 to D8 specify the data register D1 to D8 as the source, respectively.

**Examples** :View1:Source D1  
specifies the data register D1 as the view source.

**:View<x>:Version? (Query Only)**

Queries the version of the CCDFView program.

**Syntax** :View<x>:Version?

**Returns** <NR2>

**Examples** :View1:Version?  
might return 1.1.



# Self Gain-Calibration Commands

The `Util1` command group calibrates the amplifier gain based on the signal generator within the analyzer. This calibration should be run when the analyzer is started or during operation.

If you perform this calibration when the analyzer is started, carry out warm-up for 20 minutes or more after the power is turned on. This causes the analyzer electrical performance to be stable. Then, run the calibration.

When the ambient temperature varies by  $\pm 3$  °C or more relative to that at the previous calibration when the analyzer is in operation, UNCAL is displayed in red in the hardware status display area on screen. This means that the analyzer prompts you to run the calibration.

---

**NOTE.** *If you executes the calibration during signal acquisition, the analyzer stops the acquisition and then performs the calibration.*

---

**:Util1:Execute (No Query Form)**

Executes the self gain-calibration.

**Syntax** :Util1:Execute

**Arguments** None

**Examples** :Util1:Execute  
executes the self gain-calibration.

**Related Commands** :Util1:Gain:Execute, :Util1:Result<x>?

**:Util1:Gain:Auto (No Query Form)**

Determines whether to perform the self gain-calibration automatically when the analyzer is in uncal state. The calibration starts after data acquisition completes.

**Syntax** :Util1:Gain:Auto

**Arguments** None

**Examples** :Util1:Gain:Auto  
executes the self gain-calibration automatically after data acquisition when the analyzer is in uncal state.

**Related Commands** :Util1:Execute, :Util1:Gain:Execute



## **:Util1:Gain:Execute (No Query Form)**

Executes the self gain-calibration. This command is the same as the :Util1:Execute command and exists for compatibility.

**Syntax** :Util1:Gain:Execute

**Arguments** None

**Examples** :Util1:Gain:Execute  
executes the self gain-calibration.

**Related Commands** :Util1:Execute, :Util1:Result<x>?

## **:Util1:IQOffset:Execute (No Query Form)**

**3086 Only**

Compensates the offset of the I and Q input signals.

---

**NOTE.** Set the level of the I and Q input signals to zero before executing the command.

---

**Syntax** :Util1:IQOffset:Execute

**Arguments** None

**Examples** :Util1:IQOffset:Execute  
compensates the offset of the I and Q input signals.

**:Util1:Result<x>? (Query Only)**

Queries the calibration result.

**Syntax** :Util1:Result<x>?

**Returns** Result1::={ Pass | Fail } indicates the result of the self gain-calibration.

**Examples** :Util1:Result1?  
might return Pass, indicating the self gain-calibration completes successfully.

**Related Commands** :Util1:Execute, :Util1:Gain:Execute

**:Util1:Version? (Query Only)**

Queries the version of the self gain-calibration program.

**Syntax** :Util1:Version?

**Returns** <NR2>

**Examples** :Util1:Version?  
might return 1.1.

**:Util1:WideOffset:Request (No Query Form)****3086 Only**

Compensates the offset in the Wideband mode at the next data acquisition. The analyzer turns off signal input automatically.

**Syntax** :Util1:WidebandOffset:Request

**Arguments** None

**Examples** :Util1:WidebandOffset:Request  
compensates the offset of the Wideband mode at the next data acquisition.

# Save/Load Commands

The `Util2` command group allows you to save/load acquisition data to/from the hard disk or floppy disk.

Remember that the data file is composed of the following parts.

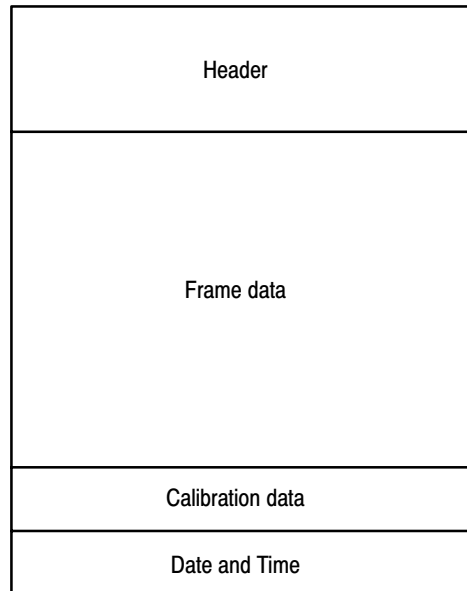

**Figure 2-11: Data file structure**

## **:Util2:AllFrames (No Query Form)**

Specifies that acquisition data in all frames are saved. Use the `:Util2:Data:SaveAP` or `:Util2:Data:SaveIQ` command to save the data.

**Syntax** `:Util2:AllFrames`

**Arguments** None

**Examples** `:Util2:AllFrames`  
specifies that acquisition data in all frames are saved.

**Related Commands** `:Util2:BeginZ`, `:Util2:Data:SaveIQ`, `:Util2:Data:SaveAP`, `:Util2:EndZ`

## **:Util2:BeginZ (?)**

Specifies or queries the first frame in the save range. This setting is used by the `:Util2:Data:SaveAP` and `:Util2:Data:SaveIQ` commands to save data. Use the `:Util2:EndZ` command to specify the last frame.

**Syntax** `:Util2:BeginZ <value>`

`:Util2:BeginZ?`

**Arguments** `<value>::=<NR1>` ranges 0 to the number of frames – 1.

**Examples** `:Util2:BeginZ 199`  
specifies that the save starts from the frame 199.

**Related Commands** `:Util2:Data:SaveAP`, `:Util2:Data:SaveIQ`, `:Util2:EndZ`

## **:Util2:Buffer:<header> (?)**

Sets or queries the file header in the buffer area read from the data source with the `:Util2:Buffer:CopyHeader` command. You can save the header with the `:Util2:Buffer:SaveHeader` command.

**Syntax** :Util2:Buffer:<header> <value>  
:Util2:Buffer:<header>?

**Arguments** The following list shows the <header> items, <value>, and their meanings.

<header>	<value>	Meaning
Bins	<NRf>	The number of bins
BlockSize	<NRf>	Block size
CenterFrequency	<NRf>	Center frequency
DateTime	<NRf>	Date and time
FFTPoints	<NRf>	The number of FFT points
FFTWindow	<string>	FFT window type
FrameLength	<NRf>	Frame length
FramePadding	<string>	The position of an invalid frame: Before or After
FramePeriod	<NRf>	Frame period
FrameReverse	<string>	Frame sequence: On (reverse) or Off (normal)
FrequencyOffset	<NRf>	Frequency offset
GainOffset	<NRf>	Gain offset
LevelOffset	<NRf>	Level offset
MaxInputLevel	<NRf>	Maximum input level
MultiAddr	<NRf>	The the last frame address in the multi-frame mode
MultiFrames	<NRf>	The number of frames in the multi-frame mode
Span	<NRf>	Span
Type	<string>	File type: IQ or AP format
UnitPeriod	<NRf>	Unit frame update period
ValidFrames	<NRf>	The number of all frames in the file

**Examples** :Util2:Buffer:MultiFrames 2  
sets the number of frames in the multi-frame mode to two in the file header.

**Related Commands** :Util2:Buffer:CopyHeader, :Util2:Buffer:SaveHeader

## **:Util2:Buffer:CopyHeader (No Query Form)**

Copies the file header from the specified data source to the buffer area. You can set the header with the `:Util2:Buffer:<header>` command, and save the header with the `:Util2:Buffer:SaveHeader` command.

**Syntax** `:Util2:Buffer:CopyHeader <source>,<beginZ>,<endZ>`

**Arguments** `<source>::={ Active | Zoom | D1 | D2 | D3 | D4 | D5 | D6 | D7 | D8 | <file_name> }` specifies the data source.

`Active` specifies the currently acquired data as the source.

`Zoom` specifies the zoomed data as the source.

`D1` to `D8` specify the data register `D1` to `D8`, respectively.

`<file_name>::=<string>` specifies the data file as the source. The file name must be `*.IQ` (the IQ format) or `*.AP` (the AP format).

`<beginZ>::=<NR1>` specifies the first frame. It ranges 0 to the number of frames – 1.

`<endZ>::=<NR1>` specifies the last frame. It ranges 0 to the number of frames – 1, or –1. –1 represents variable record length.

**Examples** `:Util2:Buffer:CopyHeader Active,199,0`  
copies the file header from the active memory for the frame 199 to 0.

The larger frame number represents the older frame. However, you can specify the frame range by changing `<beginZ>` and `<endZ>`. In this example, both `“199,0”` and `“0,199”` are possible.

**Related Commands** `:Util2:Buffer:<header>`, `:Util2:Buffer:SaveHeader`

## :Util2:Buffer:SaveHeader (No Query Form)

Saves the file header from the buffer memory to a file. You can load the header data with the :Util2:Buffer:CopyHeader command to the buffer, and set the header with the :Util2:Buffer:<header> command.

**Syntax** :Util2:Buffer:SaveHeader <source>,<destination>

**Arguments** <source>::={ Active | Zoom | D1 | D2 | D3 | D4 | D5 | D6 | D7 | D8 | <file\_name> } specifies the data source for the header.

Active specifies the currently acquired data as the source.

Zoom specifies the zoomed data as the source.

D1 to D8 specify the data register D1 to D8, respectively.

<file\_name>::=<string> specifies the data file as the source. The file name must be "\*.IQ" (the IQ format) or "\*.AP" (the AP format).

<destination>::=<file\_name>

<file\_name>::=<string> specifies the file to save the header data. The file name must be "\*.IQ" (the IQ format) or "\*.AP" (the AP format).

**Examples** :Util2:Buffer:SaveHeader Active,"SAMPLE1.IQ"  
saves the header for data on active memory to the file SAMPLE1.IQ.

**Related Commands** :Util2:Buffer:<header>, :Util2:Buffer:CopyHeader

## :Util2:Data:Load (No Query Form)

Loads the data from the file in the IQ format to the active memory.

**Syntax** :Util2:Data:Load <file\_name>

**Arguments** <file\_name>::=<string> must be "\*.IQ".

**Examples** :Util2:Data:Load "SAMPLE1.IQ"  
loads the data from the file SAMPLE1.IQ to the active memory.

**Related Commands** :Util2:Data:Save

## :Util2:Data:Save (No Query Form)

Saves the data from the specified data source to a file. All of the data including header, frame data, calibration data, date and time are saved.

**Syntax**     :Util2:Data:Save <source>,<beginZ>,<endZ>,<destination>

**Arguments**   <source>::={ Active | Zoom | D1 | D2 | D3 | D4 | D5 | D6 | D7 | D8 | <file\_name> } specifies the data source.

Active specifies the currently acquired data as the source.

Zoom specifies the zoomed data as the source.

D1 to D8 specify the data register D1 to D8, respectively.

<file\_name>::=<string> specifies the data file as the source. The file name must be “\*.IQ” (the IQ format) or “\*.AP” (the AP format).

<beginZ>::=<NR1> specifies the first frame. It ranges 0 to the number of frames – 1.

<endZ>::=<NR1> specifies the last frame. It ranges 0 to the number of frames – 1.

<destination>::=<string> specifies the file to save the data. The file name must be “\*.IQ” (the IQ format) or “\*.AP” (the AP format).

**Examples**     :Util2:Data:Save Active,199,0,"SAMPLE1.IQ"  
saves the data from the active memory for the frame 199 to 0 to the file SAMPLE1.IQ.

The larger frame number represents the older frame. However, you can specify the frame range by changing <beginZ> and <endZ>. In this example, both “199,0” and “0,199” are possible.

**Related Commands**   :Util2:Data:Load



## **:Util2:Data:SaveAP (No Query Form)**

Saves data to a file in the AP format. All of the data including header, frame data, calibration data, date and time are saved. You can specify the data source with the :Util2:Source command, and the frame range with the :Util2:ALL-Frames or the :Util2:BeginZ and :Util2:EndZ commands. The data saved in the AP format is unavailable for the modulation analysis or the zoom.

**Syntax** :Util2:Data:SaveAP <file\_name>

**Arguments** <file\_name>::=<string> must be "\*.AP".

**Examples** :Util2:Data:SaveAP "SAMPLE1.AP"  
saves the data to the file SAMPLE1.AP.

**Related Commands** :Util2:ALLFrames, :Util2:BeginZ, :Util2:EndZ, :Util2:Source,  
:Util2:Data:Save, :Util2:Data:SaveIQ

## **:Util2:Data:Saved (No Query Form)**

Informs the other programs of Utility, Configuration, Setup, and View that a file has been updated.

**Syntax** :Util2:Data:Saved [<file\_name>]

**Arguments** <file\_name>::=<string> specifies the updated file to be informed. The file name must be "\*.IQ" (the IQ format) or "\*.AP" (the AP format). If you omit the argument, the analyzer uses the file name specified with other command previously.

**Examples** :Util2:Data:Saved "SAMPLE1.IQ"  
informs the other programs that the file SAMPLE1.IQ is updated.

**:Util2:Data:SaveIQ (No Query Form)**

Saves data to a file in the IQ format. All of the data including header, frame data, calibration data, date and time are saved. You can specify the data source with the :Util2:Source command, and the frame range with the :Util2:ALLFrames or the :Util2:BeginZ and :Util2:EndZ commands.

**Syntax** :Util2:Data:SaveIQ <file\_name>

**Arguments** <file\_name>::=<string> must be “\*.IQ”.

**Examples** :Util2:Data:SaveIQ "SAMPLE1.IQ"  
saves the data to the file SAMPLE1.IQ.

**Related Commands** :Util2:ALLFrames, :Util2:BeginZ, :Util2:EndZ, :Util2:Source,  
:Util2:Data:SaveAP, :Util2:Data:Save

## :Util2:Data:SaveDateTime (No Query Form)

Adds the date and time to the file for the specified data source. Use this command only for files with variable record length.

**Syntax** :Util2:Data:SaveDateTime [<source>,<endZ>[,<destination>]

**Arguments** <source>::={ Active | Zoom | D1 | D2 | D3 | D4 | D5 | D6 | D7 | D8 | <file\_name> } specifies the data source. If you omit the <source>, the value specified in the :Util2:Buffer:SaveHeader command is used.

Active specifies the currently acquired data as the source.

Zoom specifies the zoomed data as the source.

D1 to D8 specify the data register D1 to D8, respectively.

<file\_name>::=<string> specifies the data file as the source. The file name must be "\*.IQ" (the IQ format) or "\*.AP" (the AP format).

<endZ>::=<NR1> specifies the last frame. It ranges 0 to the number of frames – 1.

<destination>::=<string> specifies the file to save the data. The file name must be "\*.IQ" (the IQ format) or "\*.AP" (the AP format). If you omit the <destination>, the value specified in the :Util2:Data:SaveHeader command is used.

**Examples** :Util2:Data:SaveDateTime Active,0,"SAMPLE1.IQ"  
adds the date and time for data on active memory to the file SAMPLE1.IQ.

**Related Commands** :Util2:Buffer:SaveHeader, :Util2:Data:SaveHeader

## **:Util2:Data:SaveFlatness (No Query Form)**

Adds the calibration data for the specified source to the file.

**Syntax**     :Util2:Data:SaveFlatness [<source>],[<destination>]

**Arguments**   <source>::={ Active | Zoom | D1 | D2 | D3 | D4 | D5 | D6 | D7 | D8 | <file\_name> } specifies the data source. If you omit <source>, the value specified in the :Util2:Buffer:SaveHeader command is used.

Active specifies the currently acquired data as the source.

Zoom specifies the zoomed data as the source.

D1 to D8 specify the data register D1 to D8, respectively.

<file\_name>::=<string> specifies the data file as the source. The file name must be "\*.IQ" (the IQ format) or "\*.AP" (the AP format).

<destination>::=<string> specifies the file to save the data. The file name must be "\*.IQ" (the IQ format) or "\*.AP" (the AP format). If you omit <destination>, the value specified in the :Util2:Data:SaveHeader command is used.

**Examples**     :Util2:Data:SaveFlatness Active,"SAMPLE1.IQ"  
adds the calibration data for currently acquired data to the file SAMPLE1.IQ.

**Related Commands**   :Util2:Buffer:SaveHeader, :Util2:Data:SaveHeader

## :Util2:Data:SaveFrame (No Query Form)

Adds frame data for the specified source to the file.

**Syntax**     :Util2:Data:SaveFrame [<source>,<beginZ>,<endZ>  
                  [,<destination>]

**Arguments**   <source>::={ Active | Zoom | D1 | D2 | D3 | D4 | D5 | D6 | D7 | D8 | <file\_name> } specifies the data source. If you omit the <source>, the value specified in the :Util2:Buffer:SaveHeader command is used.

Active specifies the currently acquired data as the source.

Zoom specifies the zoomed data as the source.

D1 to D8 specify the data register D1 to D8, respectively.

<file\_name>::=<string> specifies the data file as the source. The file name must be "\*.IQ" (the IQ format) or "\*.AP" (the AP format).

<beginZ>::=<NR1> specifies the first frame. It ranges 0 to the number of frames – 1.

<endZ>::=<NR1> specifies the last frame. It ranges 0 to the number of frames – 1.

<destination>::=<string> specifies the file to save the data. The file name must be "\*.IQ" (the IQ format) or "\*.AP" (the AP format). If you omit the <destination>, the value specified in the :Util2:Data:SaveHeader command is used.

**Examples**     :Util2:Data:SaveFrame Active,199,0,"SAMPLE1.IQ"  
                  saves the frame 199 to 0 from the active memory to the file SAMPLE1.IQ.

The larger frame number represents the older frame. However, you can specify the frame range by changing <beginZ> and <endZ>. In this example, both "199,0" and "0,199" are possible.

**Related Commands**   :Util2:Buffer:SaveHeader, :Util2:Data:SaveHeader

## **:Util2:Data:SaveHeader (No Query Form)**

Saves the header to a file for the specified data source.

**Syntax**     :Util2:Data:SaveHeader <source>,<beginZ>,<endZ>,<destination>

**Arguments**   <source>::={ Active | Zoom | D1 | D2 | D3 | D4 | D5 | D6 | D7 | D8 | <file\_name> } specifies the data source.

Active specifies the currently acquired data as the source.

Zoom specifies the zoomed data as the source.

D1 to D8 specify the data register D1 to D8, respectively.

<file\_name>::=<string> specifies the data file as the source. The file name must be "\*.IQ" (the IQ format) or "\*.AP" (the AP format).

<beginZ>::=<NR1> specifies the first frame. It ranges 0 to the number of frames -1.

<endZ>::=<NR1> specifies the last frame. It is 0 to the number of frames - 1, or -1. -1 represents variable record length.

<destination>::=<string> specifies the file to save the header. The file name must be "\*.IQ" (the IQ format) or "\*.AP" (the AP format).

**Examples**     :Util2:Data:SaveHeader Active,199,0,"SAMPLE1.IQ"  
saves the header for the frame 199 to 0 on the active memory to the file SAMPLE1.IQ.

The larger frame number represents the older frame. However, you can specify the frame range by changing <beginZ> and <endZ>. In this example, both "199,0" and "0,199" are possible.

**Related Commands**   :Util2:Data:SaveFrame, :Util2:Data:SaveFlatness,  
:Util2:Data:SaveDateTime

## :Util2:EndZ (?)

Specifies or queries the last frame in the save range. This setting is used by the :Util2:Data:SaveAP and :Util2:Data:SaveIQ commands to save data. Use the :Util2:BeginZ command to specify the first frame.

**Syntax** :Util2:EndZ <value>  
:Util2:EndZ?

**Arguments** <value>::=<NR1> ranges from 0 to the number of frames – 1.

**Examples** :Util2:EndZ 100  
sets the number of the last frame to 100.

**Related Commands** :Util2:BeginZ, :Util2:Data:SaveAP, :Util2:Data:SaveIQ

## :Util2:MarkerToFrame (No Query Form)

Specifies that the frames between the main marker and the delta marker are saved. This setting is used by the :Util2:Data:SaveAP and :Util2:Data:SaveIQ commands to save data.

**Syntax** :Util2:MarkerToFrame

**Arguments** None

**Examples** :Util2:MarkerToFrame  
specifies that the frames between the main marker and the delta marker are saved.

**Related Commands** :Util2:BeginZ, :Util2:EndZ, :Util2:Data:SaveAP, :Util2:Data:SaveIQ

## :Util2:Source (?)

Specifies or queries the data to be saved. Use the `:Util2:Data:SaveAP` or `:Util2:Data:SaveIQ` command to save the data.

**Syntax** `:Util2:Source { None | Active | Zoom | D1 | D2 | D3 | D4 | D5 | D6 | D7 | D8 | <file_name> }`  
`:Util2:Source?`

**Arguments** `None` specifies no source (no operation).  
`Active` specifies the currently acquired data as the source.  
`Zoom` specifies the zoomed data as the source.  
`D1` to `D8` specify the data register `D1` to `D8` as the source, respectively.  
`<file_name>::=<string>` specifies the data file as the source. The file name must be `*.IQ` (the IQ format) or `*.AP` (the AP format).

**Examples** `:Util2:Source Active`  
specifies the currently acquired data as the source.

**Related Commands** `:Util2:Data:SaveAP`, `:Util2:Data:SaveIQ`

## :Util2:Version? (Query Only)

Queries the version of the Save/Load program.

**Syntax** `:Util2:Version?`

**Returns** `<NR2>`

**Examples** `:Util2:Version?`  
might return `1.1`.



# Average Commands

The `Util3` command group controls averaging for the existing in-memory or -file data in the specified range.

**:Util3:AllFrames (No Query Form)**

Specifies that data in all frames are processed.

**Syntax** :Util3:AllFrames

**Arguments** None

**Examples** :Util3:AllFrames  
specifies that data in all frames are processed.

**Related Commands** :Util3:RMS, :Util3:PeakHold

**:Util3:BeginZ (?)**

Sets or queries the first frame in the process range.

**Syntax** :Util3:BeginZ <value>  
:Util3:BeginZ?

**Arguments** <value>::=<NR1> ranges 0 to the number of frames – 1.

**Examples** :Util3:BeginZ 199  
sets the first frame number to 199.

**Related Commands** :Util3:EndZ, :Util3:RMS, :Util3:PeakHold

**:Util3:Destination (?)**

Selects or queries the destination to which the process result is output.

**Syntax** :Util3:Destination { D1 | D2 | D3 | D4 | D5 | D6 | D7 | D8 }  
:Util3:Destination?

**Arguments** D1 to D8 selects the data register D1 to D8, respectively.  
The default is D1.

**Examples**     :Util3:Destination D1  
selects the D1 register as the destination.

**Related Commands**     :Util3:RMS, :Util3:PeakHold

## :Util3:EndZ (?)

Sets or queries the last frame in the process range.

**Syntax**     :Util3:EndZ <value>  
:Util3:EndZ?

**Arguments**     <value>::=<NR1> ranges 0 to the number of frames – 1.

**Examples**     :Util3:EndZ 100  
sets the last frame number to 100.

**Related Commands**     :Util3:BeginZ, :Util3:RMS, :Util3:PeakHold

## :Util3:MarkerToFrame (No Query Form)

Specifies that the frames between the main marker and the delta marker are processed.

**Syntax**     :Util3:MarkerToFrame

**Arguments**     None

**Examples**     :Util3:MarkerToFrame  
specifies that the frames between the main marker and the delta marker are processed.

**Related Commands**     :Util3:BeginZ, :Util3:EndZ, :Util3:RMS, :Util3:PeakHold

## **:Util3:PeakHold (No Query Form)**

Holds peak for each bin in the specified frame range.

**Syntax**     :Util3:PeakHold [[<source>],[<beginZ>],[<endZ>],[<destination>]]

**Arguments**   <source>::={ Active | Zoom | <file\_name> } specifies the data source. If you specify no argument, the value set with the :Util3:Source command is used.

Active specifies the currently acquired data as the source.

Zoom specifies the zoomed data as the source.

<file\_name>::=<string> specifies the data file as the source. The file name must be “\*.IQ” (the IQ format) or “\*.AP” (the AP format).

<beginZ>::=<NR1> specifies the first frame. It ranges 0 to the number of frames – 1. If you specify no argument, the value set with the :Util3:BeginZ command is used.

<endZ>::=<NR1> specifies the last frame. It ranges 0 to the number of frames – 1. If you specify no argument, the value set with the :Util3:EndZ command is used.

<destination>::={ D1 | D2 | D3 | D4 | D5 | D6 | D7 | D8 } specifies the register to store the results. If you specify no argument, the value set with the :Util3:Destination command is used.

**Examples**     :Util3:PeakHold Active,199,0,D1  
holds peak for each bin in the frame 199 to 0, and stores the results in the register D1.

The larger frame number represents the older frame. However, you can specify the frame range by changing <beginZ> and <endZ>. In this example, both “199,0” and “0,199” are possible.

**Related Commands**   :Config:Mode, :Util3:BeginZ, :Util3:EndZ, :Util3:Destination, :Util3:Source

## :Util3:RMS (No Query Form)

Calculates RMS (root mean square) for each bin in the specified frame range.

**Syntax** :Util3:RMS [[<source>],[<beginZ>],[<endZ>],[<destination>]]

**Arguments** <source>::={ Active | Zoom | <file\_name> } specifies the data source. If you specify no argument, the value set with the :Util3:Source command is used.

Active specifies the currently acquired data as the source.

Zoom specifies the zoomed data as the source.

<file\_name>::=<string> specifies the data file as the source. The file name must be “\*.IQ” (the IQ format) or “\*.AP” (the AP format).

<beginZ>::=<NR1> specifies the first frame. It ranges 0 to the number of frames – 1. If you specify no argument, the value set with the :Util3:BeginZ command is used.

<endZ>::=<NR1> specifies the last frame. It ranges 0 to the number of frames – 1. If you specify no argument, the value set with the :Util3:EndZ command is used.

<destination>::={ D1 | D2 | D3 | D4 | D5 | D6 | D7 | D8 } specifies the register to store the results. If you specify no argument, the value set with the :Util3:Destination command is used.

**Examples** :Util3:RMS Active,199,0,D1  
calculates RMS for each bin in the frame 199 to 0, and stores the results in the register D1.

The larger frame number represents the older frame. However, you can specify the frame range by changing <beginZ> and <endZ>. In this example, both “199,0” and “0,199” are possible.

**Related Commands** :Config:Mode, :Util3:BeginZ, :Util3:EndZ, :Util3:Destination, :Util3:Source

## **:Util3:Source (?)**

Specifies or queries the data source for averaging or peak hold.

**Syntax**     :Util3:Source { None | Active | Zoom | <file\_name> }  
              :Util3:Source?

**Arguments**   None specifies no source. The display area in the view will be emptied.  
              Active specifies the currently acquired data as the source.  
              Zoom specifies the zoomed data as the source.  
              D1D2 to D7D8 specify the register pair D1D2 to D7D8 as the source, respectively.  
              <file\_name>::=<string> specifies the data file as the source. The file name must be “\*.IQ” (the IQ format) or “\*.AP” (the AP format).

**Examples**     :Util3:Source Active  
                  specifies the currently acquired data as the source.

**Related Commands**   :Config:Mode, :Util3:RMS, :Util3:PeakHold

## **:Util3:Version? (Query Only)**

Queries the version of the Average program.

**Syntax**     :Util3:Version?

**Returns**    <NR2>

**Examples**    :Util3:Version?  
                  might return 1.1.

# Remote Commands

Use the Remote command group to set up the GPIB and TCP/IP interfaces.

## :Clipboard? (Query Only)

Queries the contents of the Windows clipboard. Use this command to read the clipboard after executing the command `:View<x>:CopyTo Clipboard`.

**Syntax**     `:Clipboard?`

**Arguments**   None

**Returns**     <NR1>

The line feed character (LF) will be replaced by “, ” (comma and space).

**Examples**    `:Clipboard?`

a partial response might look like this:

```
0: 00111001 00001001 01101001 11001000, 16: 10001011
01001100 11000100 01010101, 32: 01100110 00000000 10101011
11111100, 48: 00000111 11110111 11101111 11001111
```

**Related Commands**   `:View<x>:CopyTo Clipboard`

## :Set? (Query Only)

Returns a string listing the analyzer settings, except for configuration information for the calibration values. You can use this string to return the analyzer to the state it was in when you made the `:Set?` query. This command is equivalent to the IEEE 488.2 command `*LRN?`.

**Syntax**     `:Set?`

**Arguments**   None

---

**NOTE.** *The `:Set?` query always returns a string including command headers, regardless of the setting of the `[:Util8]:Header` command. This is because the returned string is intended to be sent back to the analyzer as a command string.*

---



**Examples**    :Set?  
 a partial response might look like this:  
 :Config:Util1 SelfGainCal;:Config:Util2 SaveLoad;:Config:Util3  
 Average;:Config:Util4 None;:Config:Util5 None;:Config:Util6  
 None;:Config:Util7 None;:Config:Util8 Remote;

## **[ :Util8 ]:Dev<x>:<command> (No Query Form)**

Sends the specified command to the GPIB device. The analyzer as the controller receives this [ :Util8 ]:Dev<x>:<command> command from the PC via TCP/IP, and sends the <command> to the other device through GPIB interface. You can not use this command through the GPIB interface.

**Syntax**    [ :Util8 ]:Dev<x>:<command> [<value>]

where

<x>::=<NR1> is the GPIB address of the device.

<command> is the GPIB command to be sent.

**Arguments**    <value> is the argument of the specified command.

**Examples**    :Util8:Dev1:\*IDN?  
 sends the command \*IDN? to the GPIB device with the address 1.

## **[ :Util8 ]:Error? (Query Only)**

Returns error code and message.

**Syntax**    [ :UTIL8 ]:Error?

**Returns**    <NR1>, <message>

Refer to page 3–4 for the error codes and messages.

**Examples**    :UTIL8:Error?  
 might return 0, "No error".

**[ :Util8 ]:Event:<message> (No Query Form)**

Specifies that the analyzer generates the event with the specified message. For example, when you save a file using the Save/Load commands (refer to 2–361 page) along with this command, you can determine when the process completes.

**Syntax** [ :Util8 ]:Event:<message>

where <message> specifies the event message.

**Arguments** None

**Examples** :Util2:Data:Save Active,199,0,"SAMPLE1.IQ"  
:Util8:Event:Saved  
sends the message “Saved” to the Event port when the file save operation completes.

**[ :Util8 ]:Format (?)**

Selects or queries the waveform display format. This setting is necessary to execute the [ :Util8 ]:Source:<item>? command.

**Syntax** [ :Util8 ]:Format { FreqAmpl | FreqPhase | FreqI | FreqQ | TimeAmpl | TimePhase | TimeI | TimeQ }

[ :Util8 ]:Format?

**Arguments** Defines the parameters associated with the horizontal and vertical axes:

Argument	Horizontal axis	Vertical axis
FreqAmpl	Frequency (span)	Amplitude
FreqPhase	Frequency (span)	Phase
FreqI	Frequency (span)	I (In-Phase)
FreqQ	Frequency (span)	Q (Quadrature-Phase)
TimeAmpl	Time	Amplitude
TimePhase	Time	Phase
TimeI	Time	I (In-Phase)
TimeQ	Time	Q (Quadrature-phase)

**Examples**     :View1:Format FreqAmp1  
shows the waveform with frequency along the horizontal axis and amplitude along the vertical axis.

**Related Commands**   [:Util8]:Source:<item>?

## [:Util8]:GPIB:Interface (?)

Selects or queries the GPIB configuration. You can not use this command through the GPIB interface.

**Syntax**     [:Util8]:GPIB:Interface { Off | Talker/Listener | Controller }  
[:Util8]:GPIB:Interface?

**Arguments**   Off disables all communication with the controller.  
Talker/Listener sets the analyzer to Talker and Listener.  
Controller sets the analyzer to Controller.

**Examples**     :Util8:GPIB:Interface Talker/Listener  
sets the analyzer to Talker and Listener.

## [:Util8]:GPIB:PrimaryAddress (?)

Sets or queries the GPIB primary address of the analyzer. You can not use this command through the GPIB interface.

**Syntax**     [:Util8]:GPIB:PrimaryAddress <value>  
[:Util8]:GPIB:PrimaryAddress?

**Arguments**   <value>::=<NR1> ranges 1 to 30.

**Examples**     :Util8:GPIB:PrimaryAddress 1  
sets the GPIB primary address of the analyzer to 1.

## **[:Util8]:Header (?)**

Determines whether to include or omit headers on query responses.

**Syntax**   [:Util8]:Header { On | Off }  
[:Util8]:Header?

**Arguments**   On specifies that the analyzer includes headers on applicable query responses. You can then use the query response as a command.  
  
Off specifies that the analyzer omit headers on query responses, so that only the argument is returned.

**Examples**   :Util8:Header On  
              adds header to the response.

## **[:Util8]:Id? (Query Only)**

Returns the analyzer identification code. This command is equivalent to the IEEE 488.2 command \*IDN?.

**Syntax**   [:Util8]:Id?

**Returns**   The instrument ID in the following format:  
  
SONY/Tektronix,30X6,FV:<firmware\_version\_number>,SV:  
<software\_version\_number>

**Examples**   :Util8:Id?  
              might return SONY/Tektronix,3066,FV:1.3,SV:2.0.

## [[:Util8]:Key (No Query Form)

This command is equivalent to pressing the specified front-panel button.

**Syntax** [[:Util8]:Key <button>

**Arguments** <button> specifies the front-panel button. The following table lists the arguments and their corresponding buttons.

Argument	Button	Argument	Button
Roll	<b>ROLL</b>	ViewSearch	<b>VIEW:SRCH</b>
Block	<b>BLOCK</b>	View1X1 to View2X2	View 1X1 to 2X2
PrintScreen	<b>PRINT</b>	0 to 9, ., -	Numeric keys
Mode	<b>MODE</b>	Enter	<b>ENTER/dBm</b>
Setup	<b>CONFIG:SETUP</b>	MHz	<b>MHz/s</b>
View	<b>VIEW</b>	kHz	<b>kHz/ms</b>
Util	<b>UTILITY</b>	Hz	<b>Hz/μs</b>
SetupMain	<b>SETUP:MAIN</b>	Clear	<b>CLEAR</b>
SetupFreq	<b>SETUP:FREQ</b>	BackSpace	<b>BS</b>
SetupSpan	<b>SETUP:SPAN</b>	Up/Down	Up/Down arrow button in <b>ENTRY</b>
SetupRef	<b>SETUP:REF</b>		
ViewA to ViewD	<b>VIEW:A to D</b>	StepUp/StepDown	Step up/down button beside the knob
ViewMain	<b>VIEW:MAIN</b>		
ViewScale	<b>VIEW:SCALE</b>	F1 to F8	Side buttons
ViewMarker	<b>VIEW:MARKER</b>		

**Examples** :Util8:Key Roll  
is equivalent to pressing the front-panel **ROLL** button.

## **[:Util8]:NewLine (?)**

Selects or queries the new-line character of query responses through TCP/IP.

**Syntax**    `[:Util8]:NewLine { CR | LF | CRLF }`  
`[:Util8]:NewLine?`

**Arguments**    CR sets the new-line character to Carriage Return.  
LF sets the new-line character to Line Feed.  
CRLF sets the new-line character to Carriage Return and Line Feed.

**Examples**    `:Util8:NewLine CR`  
sets the new-line character to Carriage Return.

## **[:Util8]:NumericOutput (?)**

Sets or queries the numeric format of the returned value.

**Syntax**    `:NumericOutput { EXP | SubUnit }`  
`:NumericOutput?`

**Arguments**    EXP specifies that returned-values are expressed by the scaled explicit point format, such as 1.0E-6 and 1.0E+6.  
SubUnit specifies that returned-values are expressed by the SI units (which conform to the Systeme International d'Unites standard), such as 1m and 1M.  
For more information about the unit, refer to page 2-5.

**Examples**    `:NumericOutput SubUnit`  
specifies that returned-values are expressed by the SI units.

## **[ :Util8 ]:Register:Data (No Query Form)**

Writes a value to the specified location in the data register.

**Syntax**     [ :Util8 ]:Register:Data <register>,<location>,<value>

**Arguments**     <register>::={ D1 | D2 | D3 | D4 | D5 | D6 | D7 | D8 }  
selects the data register D1 to D8, respectively.

<location>::=<NR1> is the location in the data register to write the value on.  
It ranges 0 to the number of data points on the horizontal axis – 1.

<value>::=<NRf> is the value to be written.

**Examples**     :Util8:Register:Data D1,5,0.9  
sets the sixth point in the data register D1 to 0.9.

**Related Commands**     [ :Util8 ]:Register:Header

## [ :Util8 ]:Register:Header (No Query Form)

Specifies axis scaling and labeling for the data register.

**Syntax** [ :Util8 ]:Register:Header <register>,<item>,<value>

**Arguments** <register>::={ D1 | D2 | D3 | D4 | D5 | D6 | D7 | D8 }  
selects the data register D1 to D8, respectively.

The following table lists the <item> and <value>.

<item>	<value>	Meaning
XNum	<NRf>	The number of data points on the horizontal axis. It must be less than 8142.
XStart	<NRf>	The minimum (left) edge of the horizontal axis
XScale	<NRf>	Full-scale of the horizontal axis
XUnit	<string>	The unit for the horizontal axis, e.g. Hz, s
XLeftLabel	<string>	The label displayed on the left side under the horizontal axis. "Start" displays the start value, "Center" displays the center value, otherwise displays the specified string.
XRightLabel	<string>	The label displayed on the right side under the horizontal axis. "Stop" displays the stop value, "Span" displays the span, otherwise displays the specified string.
YStart	<NRf>	The minimum (bottom) edge of the vertical axis
YScale	<NRf>	Full-scale of the vertical axis
YUnit	<string>	The unit for the vertical axis, e.g. dB, V
YMiddleUnit	<string>	The unit displayed at middle for the vertical axis, e.g. dBm
ZNum	<NRf>	The number of frames of the register: 0 or 1. 0 indicates the frame is unavailable.

**Examples** :Util8:Register:Header D1,XNum,1000  
sets the number of data points on the horizontal axis for the D1 register to 1000.

**Related Commands** [ :Util8 ]:Register:Data



**[[:Util8]:Source (?)]**

Selects or queries the data source for the [[:Util8]:Source:<item>? command.

**Syntax** [[:Util8]:Source { None | Active | Average | Zoom | D1D2 | D3D4 | D5D6 | D7D8 | D1 | D2 | D3 | D4 | D5 | D6 | D7 | D8 | <file\_name> }

[[:Util8]:Source?

**Arguments** None specifies no source. The display area in the view will be emptied.

Active specifies the currently acquired data as the source.

Average specifies the averaged data as the source. When you select this item, you have to set the average type and the number of averages using the :View<x>:Average:Type and the :View<x>:Average:Times commands, respectively.

Zoom specifies the zoomed data as the source.

D1D2 to D7D8 specify the register pair D1D2 to D7D8 as the source, respectively.

D1 to D8 specify the data register D1 to D8 as the source, respectively.

<file\_name>::=<string> specifies the data file as the source. The file name must be “\*.IQ” (the IQ format) or “\*.AP” (the AP format).

**Examples** :Util8:Source Active  
specifies the currently acquired data as the source.

**Related Commands** :Config:Mode, [[:Util8]:Source:<item>?

**[ :Util8]:Source:<item>? (Query Only)**

Queries the settings for the data source specified with the [ :Util8]:Source command. You need to set the display format with the [ :Util8]:Format command before executing this command.

**Syntax** [ :Util8]:Source:<item>?

**Returns** The following table lists the <item> and parameter type.

<b>&lt;item&gt;</b>	<b>Returns</b>	<b>Meaning</b>
Bins	<NR1>	The number of bins
BlockSize	<NRf>	Block size
CenterFrequency	<NRf>	Center frequency
DateTime	<NRf>	Date and time
FFTPoints	<NR1>	The number of FFT points
FFTWindow	<string>	FFT window type
FrameLength	<NR1>	Frame length
FramePeriod	<NRf>	Frame period
FrameReverse	<string>	Frame sequence: On (reverse) or Off (normal)
Frames	<NR1>	The number of frames
FrequencyOffset	<NRf>	Frequency offset
FrequencyDomain	On/Off	Indicates whether the frequency domain data exists or not
GainOffset	<NRf>	Gain offset
LevelOffset	<NRf>	Level offset
MaxInputLeve	<NRf>	Maximum input level
MultiAddr	<NR1>	The last frame address in the multi-frame mode
MultiFrames	<NR1>	The number of frames in the multi-frame mode
ReferenceLevel	<NRf>	Reference level
Span	<NRf>	Span

<b>&lt;item&gt;</b>	<b>Returns</b>	<b>Meaning</b>
Ticks	<NR1>	The count for time-stamping
TimeDomain	On/Off	Indicates whether the time domain data exists or not
UnitPeriod	<NRf>	Unit period for time-stamping
ValidFrames	<NRf>	The number of all frames in the file
XNum	<NR1>	The number of data points on the horizontal axis
XScale	<NRf>	Full-scale of the horizontal axis
XStart	<NRf>	The start point of the horizontal axis
XUnit	<string>	The unit of data for the horizontal axis
XLeftLabel	<string>	The label displayed on the left under the horizontal axis
XRightLabel	<string>	The label displayed on the right under the horizontal axis
YScale	<NRf>	Full-scale of the vertical axis
YStart	<NRf>	The start point of the vertical axis
YUnit	<string>	The unit of data for the vertical axis
YMiddleUnit	<string>	The unit displayed in the middle of the vertical axis
ZNum	<NR1>	The number of data points on the Z (frame) axis

**Examples**

`:Util8:Source:ReferenceLevel?`  
might return `-30`, indicating the reference level is 30 dBm.

`:Util8:Source:TimeDomain?`  
might return `Off`.

`:Util8:Source:FFTWindow?`  
might return `Blackman`.

**Related Commands** `[ :Util8 ] :Format`, `[ :Util8 ] :Source`

## **[ :Util8]:Status? (Query Only)**

Queries the status of the analyzer.

**Syntax**    [ :Util8]:Status?

**Returns**    The following table lists the responses and their meanings:

<b>Response</b>	<b>Meaning</b>
Active:Start	Data acquisition has started
Active:Stop	Data acquisition has stopped
Active:Restart	Data acquisition has restarted
Active:Block	A block data has been acquired
Active:ChangeBlock	A block data has been acquired after you changed some settings during data acquisition
Active:EndRoll	A block data has been acquired in the Roll mode
Active:ZoomStart	Zoom has started
Active:ZoomBlock	Data has been acquired for zoom
Active:ZoomStop	Zoom has stopped
Active:Quick	Data acquisition has completed in the Quick trigger mode
Active:Prepare	Data acquisition is ready
PowerOn	The analyzer is on and ready for operation

**Examples**    Util8:Status?  
might return Active:Stop.

## **[ :Util8 ]:TCPIP:Port:Command (?)**

Sets or queries the TCP/IP command port number. You can not use this command via TCP/IP. Refer to page 1–6 for information about the TCP/IP ports.

**Syntax** [ :Util8 ]:TCPIP:Port:Command <value>  
[ :Util8 ]:TCPIP:Port:Command?

**Arguments** <value>::=<NR1> ranges 1024 to 32767. It must not be the same as the event port number.

**Examples** :Util8:TCPIP:Port:Command 3000  
sets the command port number to 3000.

**Related Commands** [ :Util8 ]:TCPIP:Port:Command:Reset, [ :Util8 ]:TCPIP:Port:Event

## **[ :Util8 ]:TCPIP:Port:Command:Reset (No Query Form)**

Disconnects the TCP/IP command port from the network, and closes command input and response output. You can not use this command via TCP/IP. Refer to page 1–6 for information about the TCP/IP ports.

**Syntax** [ :Util8 ]:TCPIP:Port:Command:Reset

**Arguments** None

**Examples** :Util8:TCPIP:Port:Command:Reset  
closes the TCP/IP command port.

**Related Commands** [ :Util8 ]:TCPIP:Port:Command

## **[ :Util8 ]:TCPIP:Port:Event (?)**

Sets or queries the TCP/IP event port number. You can not use this command via TCP/IP. Refer to page 1–6 for information about the TCP/IP ports.

**Syntax**     [ :Util8 ]:TCPIP:Port:Event <value>  
              [ :Util8 ]:TCPIP:Port:Event?

**Arguments**     <value>::=<NR1> ranges 1024 to 32767. It must not be the same as the command port number.

**Examples**     :Util8:TCPIP:Port:Event 3001  
                  sets the TCP/IP event port number to 3001.

**Related Commands**     [ :Util8 ]:TCPIP:Port:Command

## **[ :Util8 ]:TCPIP:Port:Event:Reset (No Query Form)**

Disconnects the TCP/IP event port from the network, and closes event output. You can not use this command via TCP/IP. Refer to page 1–6 for information about the TCP/IP ports.

**Syntax**     [ :Util8 ]:TCPIP:Port:Event:Reset

**Arguments**     None

**Examples**     :Util8:TCPIP:Port:Event:Reset  
                  closes the TCP/IP event port.

**Related Commands**     [ :Util8 ]:TCPIP:Port:Event

## **[[:Util8]:Version? (Query Only)**

Queries the version of the Remote program.

**Syntax**    [[:Util8]:Version?

**Returns**    <NR2>

**Examples**    :Util8:Version?  
                 might return 1.1.

## **[[:Util8]:ViewName? (Query Only)**

Queries the name of the Remote program.

**Syntax**    [[:Util8]:ViewName?

**Returns**    <string>::="Util<X>"

**Examples**    :Util8:ViewName?  
                 might return Util8.

## **[[:Util8]:Z (?)**

Specifies or queries the frame number for the [[:Util8]:Z:<item>? command.

**Syntax**    [[:Util8]:Z <value>  
                 [[:Util8]:Z?

**Arguments**    <value>::=<NR1> ranges from 0 to the number of frames – 1.

**Examples**    :Util8:Z 199  
                 sets the frame number to 199.

**Related Commands**    [[:Util8]:Z:<item>?

**[ :Util8 ] : Z : < item > ? (Query Only)**

Queries the time stamp or the status of the frame specified with the [ :Util8 ] : Z command.

**Syntax** [ :Util8 ] : Z : < item > ?

**Returns** The following table lists the < item >, the returned values, and their meanings:

< item >	Returned value	Meaning
TimeStamp	< NRf >	Time stamp for the frame
Status	NORMAL	The frame is normal.
	INVALID	The frame has no data.
	MISSFRAME	The frame was not acquired within the specified period.
	OVERLOAD	The analyzer's A/D converter overloads.
	TRIGGERED	The analyzer has been triggered.
	LASTFRAME	The frame is the last one.

The time stamp is zero when the last frame is acquired.

**Examples** :Util8:Z:TimeStamp?  
might return  $-1.6e-4$ , indicating that the frame was acquired 160  $\mu$ s before the last frame.

:Util8:Z:Status?  
might return OVERLOAD, TRIGGERED.

**Related Commands** [ :Util8 ] : Z



## Retrieving Response Message

When a query command is sent from the external controller, the analyzer puts the response message on the output buffer. This response message cannot be retrieved unless you perform a retrieval operation through the external controller. For example, call IBRD subroutine with the National Instruments drivers.

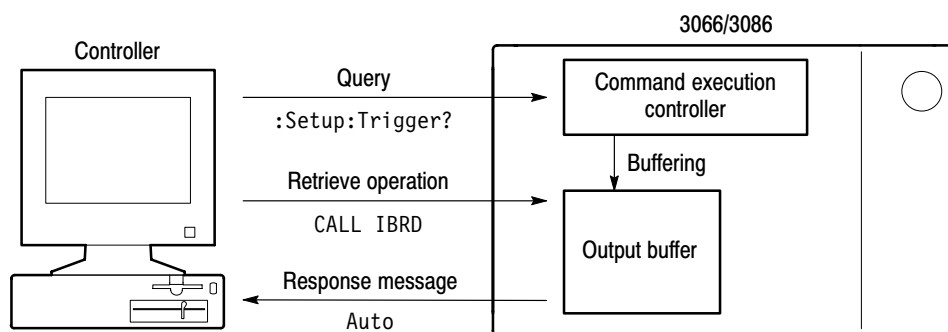

**Figure 2-12: Retrieving response message**

Current response message overwrites the previous response message, if any. When you send a chained queries to the analyzer, such as :Setup:Span?; ReferenceLevel?; Trigger?, all the response messages will be written in the output buffer. These messages remain in the buffer until the next query responses overwrite them.



# Status and Events



# Status and Events

The analyzer provides a status and event reporting system for the GPIB and TCP/IP Ethernet interface. This system informs you of certain significant events that occur within the analyzer.

## Obtaining Event and Error Messages

Event and error messages can be obtained by using the following queries:

- Status? query returns the latest event.
- Error? query returns the error code and message in the following format:

<error code>,"<error message>"

Also, you can use the status port in TCP/IP environment. Refer to the next topic below.

Table 3-2 to 3-7 on page 3-3 to 3-5 show all event and error messages.

## TCP/IP Event Port

In TCP/IP environment, the analyzer always sends the event message to the Event port. Access this port from your program to get the latest event. Refer to page 1-7 for setting the port.

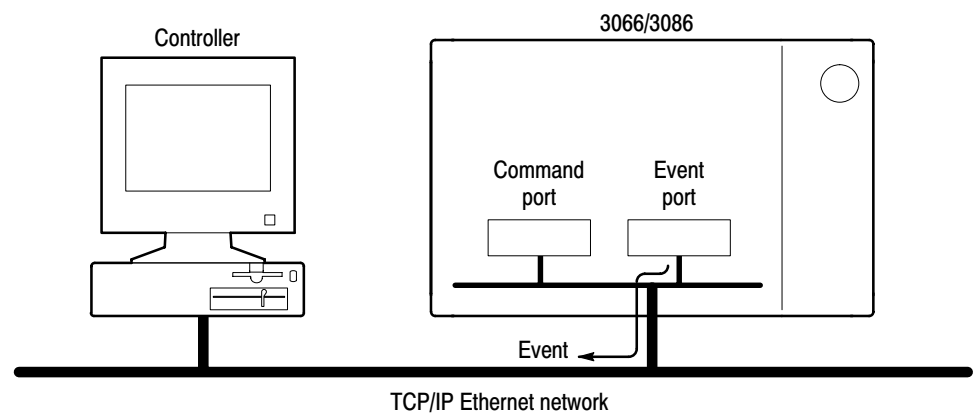
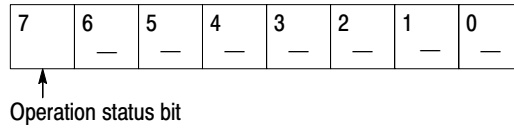

**Figure 3-1: Obtaining event on the TCP/IP Ethernet**

## Status Byte Register (SBR)

The analyzer has one 8-bit register, called Status Byte Register (SBR) to handle the status. Only the bit 7 is used to indicate whether the analyzer is acquiring data.

You can read the SBR register from your program. For example, call IBRSP subroutine with the National Instruments drivers.



**Figure 3-2: The Status Byte Register (SBR)**

**Table 3-1: SBR bit functions**

Bit	Function
7	Operation Status Bit. This bit is set when acquiring data.
6 – 0	Not used.

## Messages

Tables 3–2 to 3–7 list all the programming interface messages the analyzer generates in response to commands and queries.

### Event Messages

These are certain types of events that may occur while the analyzer is in use. You can get these messages with the Status? command. You can also access to the status port via TCP/IP (option) to obtain events.

**Table 3–2: Event message**

Returned value	Meaning
Active:Start	Data acquisition has started
Active:Stop	Data acquisition has stopped
Active:Restart	Data acquisition has restarted
Active:Block	A block data has been acquired
Active:ChangeBlock	A block data has been acquired after you changed some settings during data acquisition
Active:EndRoll	A block data has been acquired in the Roll mode
Active:ZoomStart	Zoom has started
Active:ZoomBlock	Data has been acquired for zoom
Active:ZoomStop	Zoom has stopped
Active:Quick	Data acquisition has completed in the Quick trigger mode
Active:Prepare	Data acquisition is ready
PowerOn	The analyzer is on and ready for operation

**Error Messages** You can get these messages with the Error? command.

**No Error.** Table 3–7 shows the messages when the system has no error.

**Table 3–3: No error**

Code	Message
0	No error

**Command Error.** Command error is returned when there is a syntax error in the command.

**Table 3–4: Command error**

Code	Message
-100	Command error

**Execution Error.** These error codes and messages are returned when an error is detected while a command is being executed.

**Table 3–5: Execution error**

Code	Message
-200	Execution error
-220	Parameter error
-225	Out of memory
-250	Mass storage error
-254	Media full
-256	File name not found
-257	File name error
-258	Media protected



**Device Specific Error.** These error codes and messages are returned when an internal instrument error is detected. This type of error may indicate a hardware problem.

**Table 3-6: Device specific error**

Code	Message
-300	Device specific error

**GPIB Error.** These error codes are returned when a GPIB error is detected.

**Table 3-7: GPIB error**

Code	Message
2000	System error Function requires GPIB board to be CIC Write function detected no Listeners Interface board not addressed correctly Invalid argument to function call Function requires GPIB board to be SAC I/O operation aborted Non-existent interface board Error performing DMA I/O operation started before previous (Operation completed) No capability for intended operation (Operation completed) File system operation error (Operation completed) Serial poll status byte lost (Operation completed) SRQ remains asserted (Operation completed) The return buffer is full (Operation completed) Address or board is locked



# Programming Examples



# Programming Examples

This section lists two example programs that illustrate methods you can use to control the analyzer from your application over the TCP/IP Ethernet network. These programs are written in the PERL (a freeware).

- Example 1 acquires a block of data and averages them.
- Example 2 writes peak-hold data of 30 frames to a file every 3 seconds.

## Example 1

```
#
# Acquire a block of data and average them.
#

# Load the TCP/IP library
use lib 'c:\Program Files\SONY Tektronix\3066\Perl';
use TCPIP; # Refer to "TCP/IP setup program" on page 4-4.

# End process routine
sub signal_handler
{
    shutdown(SS, 2);
    print S "Config:Pause Off\n";
    shutdown(S, 2);
    die @_;
}
$SIG{'INT'} = 'signal_handler';
$SIG{'BREAK'} = 'signal_handler';

#
# Main
#
tcp_client(S, '', '3000');
tcp_client(SS, '', '3001');

print S "NewLine LF\n";
print S "Config:Pause On\n";
print S "Config:View1 Waveform\n";
print S "View1:Trace2:Source D1\n";
print S "Setup:Span?\n"; chomp($tmp = <S>);
    if ($tmp > 50e6) {print S "Setup:Span 50e6\n";}
print S "Setup:BlockSize 20\n";
print S "Setup:TriggerCount Off\n";

print "Press BLOCK button \n";
```

```

while (<SS>)
{
    print;
    chomp;

    if (/^Active:/)
    {
        if (/Block/) {print S "Util3:RMS Active,19,0,D1\n";}
        print S "Config:Continue\n";
    }
}
signal_handler;

```

**Example 2**

```

#
# Write peak-hold data of 30 frames to a file every 3 seconds.
# See the figure below.
#

# Load the TCP/IP library
use lib 'c:\Program Files\SONY Tektronix\3066\Perl';
use TCPIP; # Refer to "TCP/IP setup program" on page 4-4.

# End process routine
sub signal_handler
{
    shutdown(SS, 2);
    print S "Config:Pause Off\n";
    shutdown(S, 2);
    die @_ ;
}
$SIG{'INT'} = 'signal_handler';
$SIG{'BREAK'} = 'signal_handler';

#
# Main
#
tcp_client(S, '', '3000');
tcp_client(SS, '', '3001');

print S "NewLine LF\n";
print S "Config:Pause On\n";
print S "Config:View1 Waveform\n";
print S "View1:Source Active\n";
print S "Setup:Span?\n"; chomp($tmp = <S>);
    if ($tmp > 50e6) {print S "Setup:Span 50e6\n";}
print S "Setup:BlockSize 30\n";

```

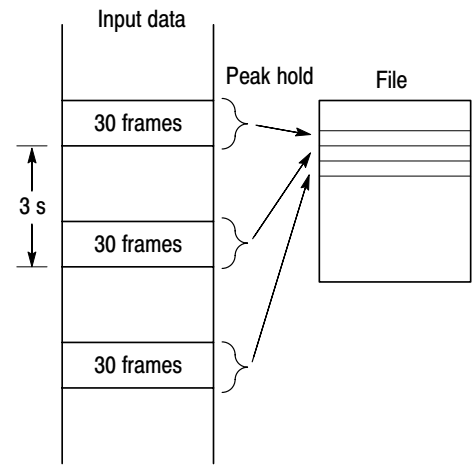

```

print S "Setup:Trigger Interval\n";
print S "Setup:TriggerCount On\n";
print S "Setup:TriggerTimes 10\n";
print S "Setup:TriggerInterval 3\n";

print "Press BLOCK button \n";

$file = 'IntBlock.ap';
$c = 0; # The number of acquisitions

while (<SS>)
{
    print;
    chomp;

    if (/^Active:/)
    {
        if (/Block/)
        {
            print S "Util3:PeakHold Active,29,0,D1\n";
            # If you clear the UnitPeriod value in the header, it is
            # automatically set to 100 ms by the Util2:Data:SaveHeader
            # command.
            #print S "Register:Header D1,UnitPeriod,\"\"";
            if ($c == 0)
            {
                print S "Util2:Data:SaveHeader D1,0,-1,$file\n";
            }
            print S "Util2:Data:SaveFrame D1,0,0\n";
            $c++;
        }
        if (/Stop/)
        {
            if ($c > 0)
            {
                print S "Util2:Data:SaveFlatness D1\n";
                print S "Util2:Data:SaveDateTime D1,0\n";
                print S "Util2:Data:Saved\n";
                $c = 0;
            }
        }
        print S "Config:Continue\n";
    }
}
signal_handler;

```

```
#
# TCP/IP setup program
#
package TCPIP;
use strict "subs";
use Socket;
use Exporter;
@ISA = qw(Exporter);
@EXPORT = qw(tcp_server tcp_client);

#
# Usage: tcp_server(handle[, port=3066])
#
sub tcp_server ($$)
{
    my ($H, $port) = @_ ;
    my $p = caller;      # Specify the caller
    $H = $p . "::-" . $H; # Declare the caller
    $port = $port || 3066;
    $proto = getprotobyname('tcp');
    $port = getservbyname($port, 'tcp') unless $port =~ /\^d+\/;

    socket($H, PF_INET, SOCK_STREAM, $proto) || die "socket: $!";
    $ent = sockadr_in($port, INADDR_ANY);
    bind($H, $ent) || die "bind: $!";
    listen($H, 5) || die "listen: $!";
}

#
# Usage: tcp_client handle[, host[, port=3066]]
#
sub tcp_client ($;$)
{
    my ($H, $host, $port) = @_ ;
    my $p = caller;      # Specify the caller
    $H = $p . "::-" . $H; # Declare the caller
    $host = $host || "localhost";
    $port = $port || 3066;

    my $proto = getprotobyname('tcp');
    socket($H, PF_INET, SOCK_STREAM, $proto);
    $port = getservbyname($port, 'tcp') unless $port =~ /\^d+\/;
    $ent = sockadr_in($port, inet_aton($host));
    connect($H, $ent) || die "connect : $!";
    select($H); $| = 1; select(STDOUT);      # Inhibit buffering
}
1;
```



# Appendices



# Appendix A: Character Charts

Table A-1: The 3066 character set

	0	1	2	3	4	5	6	7
<b>0</b>	<b>NUL</b> 0		<b>space</b> 32	<b>0</b> 48	<b>@</b> 64	<b>P</b> 80	<b>'</b> 96	<b>p</b> 112
<b>1</b>			<b>!</b> 33	<b>1</b> 49	<b>A</b> 65	<b>Q</b> 81	<b>a</b> 97	<b>q</b> 113
<b>2</b>			<b>”</b> 34	<b>2</b> 50	<b>B</b> 66	<b>R</b> 82	<b>b</b> 98	<b>r</b> 114
<b>3</b>			<b>#</b> 35	<b>3</b> 51	<b>C</b> 67	<b>S</b> 83	<b>c</b> 99	<b>s</b> 115
<b>4</b>			<b>\$</b> 36	<b>4</b> 52	<b>D</b> 68	<b>T</b> 84	<b>d</b> 100	<b>t</b> 116
<b>5</b>			<b>%</b> 37	<b>5</b> 53	<b>E</b> 69	<b>U</b> 85	<b>e</b> 101	<b>u</b> 117
<b>6</b>			<b>&amp;</b> 38	<b>6</b> 54	<b>F</b> 70	<b>V</b> 86	<b>f</b> 102	<b>v</b> 118
<b>7</b>			<b>'</b> 39	<b>7</b> 55	<b>G</b> 71	<b>W</b> 87	<b>g</b> 103	<b>w</b> 119
<b>8</b>			<b>(</b> 40	<b>8</b> 56	<b>H</b> 72	<b>X</b> 88	<b>h</b> 104	<b>x</b> 120
<b>9</b>	<b>HT</b> 9		<b>)</b> 41	<b>9</b> 57	<b>I</b> 73	<b>Y</b> 89	<b>i</b> 105	<b>y</b> 121
<b>A</b>	<b>LF</b> 10		<b>*</b> 42	<b>:</b> 58	<b>J</b> 74	<b>Z</b> 90	<b>j</b> 106	<b>z</b> 122
<b>B</b>		<b>ESC</b> 27	<b>+</b> 43	<b>;</b> 59	<b>K</b> 75	<b>[</b> 91	<b>k</b> 107	<b>{</b> 123
<b>C</b>			<b>,</b> 44	<b>&lt;</b> 60	<b>L</b> 76	<b>\</b> 92	<b>l</b> 108	<b> </b> 124
<b>D</b>	<b>CR</b> 13		<b>—</b> 45	<b>=</b> 61	<b>M</b> 77	<b>]</b> 93	<b>m</b> 109	<b>}</b> 125
<b>E</b>			<b>.</b> 46	<b>&gt;</b> 62	<b>N</b> 78	<b>^</b> 94	<b>n</b> 110	<b>~</b> 126
<b>F</b>			<b>/</b> 47	<b>?</b> 63	<b>O</b> 79	<b>_</b> 95	<b>o</b> 111	<b>rubout</b> 127

Table A-2: ASCII & GPIB code chart

B7 B6 B5 BITS B4 B3 B2 B1	0 0 0		0 0 1		0 1 0		0 1 1		1 0 0		1 0 1		1 1 0		1 1 1	
	CONTROL				NUMBERS SYMBOLS				UPPER CASE				LOWER CASE			
0 0 0 0	0	NUL	20	DLE	40	SP	60	0	100	@	120	P	140	,	160	p
0 0 0 1	1	SOH	21	DC1	41	!	61	1	101	A	121	Q	141	a	161	q
0 0 1 0	2	STX	22	DC2	42	"	62	2	102	B	122	R	142	b	162	r
0 0 1 1	3	ETX	23	DC3	43	#	63	3	103	C	123	S	143	c	163	s
0 1 0 0	4	EOT	24	DC4	44	\$	64	4	104	D	124	T	144	d	164	t
0 1 0 1	5	ENQ	25	NAK	45	%	65	5	105	E	125	U	145	e	165	u
0 1 1 0	6	ACK	26	SYN	46	&	66	6	106	F	126	V	146	f	166	v
0 1 1 1	7	BEL	27	ETB	47	'	67	7	107	G	127	W	147	g	167	w
1 0 0 0	10	GET	30	SPE	50	(	70	8	110	H	130	X	150	h	170	x
1 0 0 1	11	TCT	31	SPD	51	)	71	9	111	I	131	Y	151	i	171	y
1 0 1 0	12	LF	32	SUB	52	*	72	:	112	J	132	Z	152	j	172	z
1 0 1 1	13	VT	33	ESC	53	+	73	;	113	K	133	[	153	k	173	{
1 1 0 0	14	FF	34	FS	54	,	74	<	114	L	134	\	154	l	174	
1 1 0 1	15	CR	35	GS	55	-	75	=	115	M	135	]	155	m	175	}
1 1 1 0	16	SO	36	RS	56	.	76	>	116	N	136	^	156	n	176	~
1 1 1 1	17	SI	37	US	57	/	77	?	117	O	137	-	157	o	177	RUBOUT (DEL)
	ADDRESSED COMMANDS		UNIVERSAL COMMANDS		LISTEN ADDRESSES				TALK ADDRESSES				SECONDARY ADDRESSES OR COMMANDS			

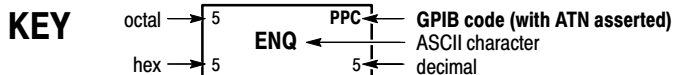

**Tektronix**  
 REF: ANSI STD X3.4-1977  
 IEEE STD 488.1-1987  
 ISO STD 646-2973

# Appendix B: Factory Initialization Settings

The factory initialization settings provide you a known state for the analyzer. Factory initialization sets the values as shown in Table B-1 to B-26 for each command group. Table B-27 and B-28 present those values for the :Config:Mode command by its arguments.

## Configuration Commands

**Table B-1: Factory initialization settings — Configuration commands**

Header	Default settings
Config:Setup	Standard
Config:BackgroundColor	Black
Config:MarkerLink	On
Config:Util<x>	Util1 Self Gain-Calibration
	Util2 Save/Load
	Util3 Average
	Util8 Remote
Config:View:Style	1 × 1
Config:View<x>	View1 Waveform

## Setup Commands

**Table B-2: Factory initialization settings — Setup commands**

Header	Default settings - Standard	Default settings - CDMA
:Setup:BlockSize	Max. 200 (depends on span)	200
:Setup:CDMA:Channel	-	1
:Setup:CDMA:Standard	-	IS95
:Setup:CDMA:TriggerLevel	-	-30 dBm
:Setup:CenterFrequency	1.5 GHz	-
:Setup:FFTPoints	1024	-
:Setup:FFTWindow	Blackman	-
:Setup:FramePeriod	80 $\mu$ s	-
:Setup:FrequencyOffset	0	-
:Setup:InputCoupling	AC	-
:Setup:InputMode	RF	-
:Setup:LevelOffset	0	-
:Setup:MemoryMode	Frequency	-
:Setup:ReferenceLevel	0 dBm	0 dBm
:Setup:ReferenceOsc	Internal	Internal
:Setup:Span	3 GHz	5 MHz
:Setup:Trigger	Auto	Auto
:Setup:TriggerCount	On	On
:Setup:TriggerDelayed	0	0
:Setup:TriggerDomain	Frequency	Frequency
:Setup:TriggerInterval	60	60
:Setup:TriggerPosition	50 %	50 %
:Setup:TriggerSlope	Rise	Rise
:Setup:TriggerSource	Internal	Internal
:Setup:TriggerTimeout	0	0
:Setup:TriggerTimes	1	1
:Setup:Zoom:Frequency	0	-
:Setup:Zoom:Mag	2	-

## View Commands

**Table B-3: Factory initialization settings — Waveform View commands**

Header	Default settings
:View<x>:Average:Times	10
:View<x>:Average:Type	RMSExpo
:View<x>:Compression	Max
:View<x>:Edit	Off
:View<x>:Format	FreqAmpl
:View<x>:Marker:Band:Left	0
:View<x>:Marker:Band:Right	0
:View<x>:Marker:Band:Width	0
:View<x>:Marker:DeltaMarker	Off
:View<x>:Marker:DeltaX	0
:View<x>:Marker:SearchSeparation	2 %
:View<x>:Marker:Trace	Trace1
:View<x>:Marker:X	0
:View<x>:MaskVisible	Off
:View<x>:Measurement	Off
:View<x>:Measurement:ACP:BW	0
:View<x>:Measurement:ACP:Marker	Center
:View<x>:Measurement:ACP:SP	0
:View<x>:Measurement:OBW	99 %
:View<x>:Position	100 %
:View<x>:Scale:XScale	1
:View<x>:Scale:XStart	0
:View<x>:Scale:YScale	0
:View<x>:Scale:YStart	0
:View<x>:Source	Active
:View<x>:Trace2:Compression	Max
:View<x>:Trace2:Format	FreqAmpl
:View<x>:Trace2:Source	None
:View<x>:Trace2:Z	0
:View<x>:Z	0

**Table B-4: Factory initialization settings — Analog View commands**

Header	Default settings
:View<x>:Format	AM
:View<x>:Marker:DeltaMarker	Off
:View<x>:Marker:DeltaX	0
:View<x>:Marker:SearchSeparation	2 %
:View<x>:Marker:X	0
:View<x>:Scale:XScale	1
:View<x>:Scale:XStart	0
:View<x>:Scale:YScale	200
:View<x>:Scale:YStart	-200
:View<x>:Source	Active
:View<x>:Z	0

**Table B-5: Factory initialization settings — FSK View commands**

Header	Default settings
:View<x>:Marker:DeltaMarker	Off
:View<x>:Marker:DeltaX	0
:View<x>:Marker:X	0
:View<x>:Scale:XScale	1
:View<x>:Scale:XStart	0
:View<x>:Scale:YScale	0
:View<x>:Scale:YStart	0
:View<x>:Source	Active
:View<x>:Z	0

**Table B-6: Factory initialization settings — Spectrogram View commands**

Header	Default settings
:View<x>:Compression	Max
:View<x>:Format	FreqAmpl
:View<x>:Marker:DeltaMarker	Off
:View<x>:Marker:DeltaX	0



**Table B-6: Factory initialization settings — Spectrogram View commands (Cont.)**

<b>Header</b>	<b>Default settings</b>
:View<x>:Marker:DeltaZ	0
:View<x>:Marker:SearchSeparation	2 %
:View<x>:Marker:X	0
:View<x>:Marker:Z	0
:View<x>:Monochrome	Off
:View<x>:NumberColors	100
:View<x>:Scale:XScale	1
:View<x>:Scale:XStart	0
:View<x>:Scale:YScale	20
:View<x>:Scale:YStart	0
:View<x>:Scale:ZScale	0
:View<x>:Scale:ZStart	0
:View<x>:Source	Active
:View<x>:ZGap	1 pixel

**Table B-7: Factory initialization settings — Waterfall View commands**

<b>Header</b>	<b>Default settings</b>
:View<x>:Compression	Max
:View<x>:Format	FreqAmpl
:View<x>:Marker:DeltaMarker	Off
:View<x>:Marker:DeltaX	0
:View<x>:Marker:DeltaZ	0
:View<x>:Marker:SearchSeparation	2 %
:View<x>:Marker:X	0
:View<x>:Marker:Z	0
:View<x>:Scale:XScale	1
:View<x>:Scale:XStart	0
:View<x>:Scale:YScale	20
:View<x>:Scale:YStart	0
:View<x>:Scale:ZScale	0
:View<x>:Scale:ZStart	0

**Table B-7: Factory initialization settings — Waterfall View commands (Cont.)**

Header	Default settings
:View<x>:Source	Active
:View<x>:YHeight	20
:View<x>:ZGap	5

**Table B-8: Factory initialization settings — Polar View commands**

Header	Default settings
:View<x>:AlphaBT	0.5
:View<x>:AutoCarrier	On
:View<x>:Burst:BlockSize	4
:View<x>:Burst:NumberFrames	1
:View<x>:Burst:Offset	0
:View<x>:Burst:Search	Off
:View<x>:Burst:Threshold	-20 dB
:View<x>:Carrier	0
:View<x>:Display	Measurement
:View<x>:Format	Vector
:View<x>:Marker:T	0
:View<x>:MeasDestination	D5D6
:View<x>:MeasFilter	RootRaisedCosine
:View<x>:Modulation	1/4 $\pi$ QPSK
:View<x>:Position	100 %
:View<x>:RefDestination	D7D8
:View<x>:RefFilter	RaisedCosine
:View<x>:Source	Active
:View<x>:SymbolRate	21 k
:View<x>:Z	0

**Table B-9: Factory initialization settings — Eye diagram View commands**

Header	Default settings
:View<x>:EyeLength	2
:View<x>:Format	1
:View<x>:Marker:T	0
:View<x>:Source	Measurement

**Table B-10: Factory initialization settings — Symbol View commands**

Header	Default settings
:View<x>:Marker:T	0
:View<x>:Radix	Bin
:View<x>:Rotate	0
:View<x>:Source	Measurement

**Table B-11: Factory initialization settings — EVM View commands**

Header	Default settings
:View<x>:Format	EVM
:View<x>:Marker:DeltaMarker	Off
:View<x>:Marker:DeltaX	0
:View<x>:Marker:X	0
:View<x>:MaskArea	5 %
:View<x>:Scale:XScale	1
:View<x>:Scale:XStart	0
:View<x>:Scale:YScale	100
:View<x>:Scale:YStart	0

**Table B-12: Factory initialization settings — CDMA Waveform View commands**

Header	Default settings
:View<x>:Average:Times	10
:View<x>:Average:Type	RMSExpo
:View<x>:CDMA:Channel	1
:View<x>:CDMA:Standard	IS95
:View<x>:Compression	Max
:View<x>:Format	FreqAmpl
:View<x>:Marker:DeltaMarker	Off
:View<x>:Marker:DeltaX	0
:View<x>:Marker:SearchSeparation	2 %
:View<x>:Marker:X	0
:View<x>:Mask:RBW1M:Frequency	1.385 MHz
:View<x>:Mask:RBW1M:Level	-60
:View<x>:Mask:RBW30k:Frequency1	900 k
:View<x>:Mask:RBW30k:Frequency2	1.98 MHz
:View<x>:Mask:RBW30k:Level1	-42
:View<x>:Mask:RBW30k:Level2	-54
:View<x>:Measurement	Off
:View<x>:Measurement:OBW	99
:View<x>:Measurement:Separation	2
:View<x>:Measurement:SortedBy	Frequency
:View<x>:Measurement:SpuriousSearch	Off
:View<x>:Measurement:Threshold	-100
:View<x>:Position	100 %
:View<x>:RBW	30 kHz
:View<x>:Scale:XScale	1
:View<x>:Scale:XStart	0
:View<x>:Scale:YScale	0
:View<x>:Scale:YStart	0
:View<x>:Source	Active
:View<x>:Z	0

**Table B-13: Factory initialization settings — CDMA Polar View commands**

Header	Default settings
:View<x>:AlphaBT	0.2
:View<x>:AutoCarrier	On
:View<x>:Burst:BlockSize	5
:View<x>:Burst:NumberFrames	2
:View<x>:Burst:Offset	0
:View<x>:Burst:Search	Off
:View<x>:Burst:Threshold	-20 dB
:View<x>:Carrier	0
:View<x>:Display	Measurement
:View<x>:Format	Constellation
:View<x>:Marker:T	0
:View<x>:MeasDestination	D5D6
:View<x>:MeasFilter	RootRaisedCosine
:View<x>:Modulation	1/4 $\pi$ QPSK
:View<x>:Position	100 %
:View<x>:RefDestination	D7D8
:View<x>:RefFilter	RaisedCosine
:View<x>:Source	Active
:View<x>:SymbolRate	1.2288 MHz
:View<x>:Z	0

**Table B-14: Factory initialization settings — CDMA Time View commands**

Header	Default settings
:View<x>:Average:Times	10
:View<x>:Block	0
:View<x>:Marker:DeltaMarker	Off
:View<x>:Marker:DeltaX	0
:View<x>:Marker:SearchSeparation	2 %
:View<x>:Marker:X	0
:View<x>:Mask:OffLeft	169 $\mu$ s
:View<x>:Mask:OffLevel	-20

**Table B-14: Factory initialization settings — CDMA Time View commands (Cont.)**

Header	Default settings
:View<x>:Mask:OffRight	1.431 ms
:View<x>:Mask:OnLeft	175 $\mu$ s
:View<x>:Mask:OnLevel	-3
:View<x>:Mask:OnRight	1.425 ms
:View<x>:Position	0
:View<x>:Scale:XScale	1
:View<x>:Scale:XStart	0
:View<x>:Scale:YScale	0
:View<x>:Scale:YStart	0
:View<x>:Source	Active
:View<x>:Trace:TraceVisible	On
:View<x>:Trace2:TraceVisible	Off

**Table B-15: Factory initialization settings — CodeSpectrogram View commands (3066 option 15 and 3086 option 16 only)**

Header	Default settings
:View<x>:Marker:DeltaMarker	Off
:View<x>:Marker:SearchSeparation	2 %
:View<x>:Marker:X	0
:View<x>:Marker:Z	0
:View<x>:Monochrome	Off
:View<x>:NumberColors	100
:View<x>:Scale:XScale	1
:View<x>:Scale:XStart	0
:View<x>:Scale:YScale	20
:View<x>:Scale:YStart	0
:View<x>:Scale:ZScale	0
:View<x>:Scale:ZStart	0
:View<x>:ZGap	3 pixels

**Table B-16: Factory initialization settings — CodePolar View commands (3066 option 15 and 3086 option 16 only)**

Header	Default settings
:View<x>:AlphaBT	0.2
:View<x>:Analysis:TimeSlot	0
:View<x>:AutoCarrier	On
:View<x>:Carrier	0
:View<x>:Display	Measurement
:View<x>:Format	Vector
:View<x>:Marker:T	0
:View<x>:MeasFilter	RootRaisedCosine
:View<x>:Modulation	IS-95+EQ
:View<x>:RefFilter	RaisedCosine
:View<x>:Source	Active
:View<x>:SymbolRate	1.2288 MHz
:View<x>:Z	0

**Table B-17: Factory initialization settings — CodePower View commands (3066 option 15 and 3086 option 16 only)**

Header	Default settings
:View<x>:Average	Off
:View<x>:Average:BeginZ	0
:View<x>:Average:EndZ	0
:View<x>:Average:Times	10
:View<x>:Average:Type	RMSExpo
:View<x>:Marker:DeltaMarker	Off
:View<x>:Marker:SearchSeparation	2 %
:View<x>:Marker:X	0
:View<x>:Scale:XScale	1
:View<x>:Scale:XStart	0
:View<x>:Scale:YScale	0
:View<x>:Scale:YStart	0
:View<x>:Z	0

**Table B-18: Factory initialization settings — CodeWSpectrogram View commands (3086 option 16 only)**

Header	Default settings
:View<x>:Marker:DeltaMarker	Off
:View<x>:Marker:SearchSeparation	2 %
:View<x>:Marker:X	0
:View<x>:Marker:Z	0
:View<x>:Monochrome	Off
:View<x>:NumberColors	100
:View<x>:Scale:XScale	1
:View<x>:Scale:XStart	0
:View<x>:Scale:YScale	20
:View<x>:Scale:YStart	0
:View<x>:Scale:ZScale	0
:View<x>:Scale:ZStart	0
:View<x>:SymbolRate	Composite
:View<x>:ZGap	3 pixels

**Table B-19: Factory initialization settings — CodeWPolar View commands (3086 option 16 only)**

Header	Default settings
:View<x>:AlphaBT	0.22
:View<x>:Analysis:TimeSlot	0
:View<x>:AutoCarrier	On
:View<x>:Carrier	0
:View<x>:Display	Measurement
:View<x>:Format	Vector
:View<x>:Marker:T	0
:View<x>:MeasFilter	RootRaisedCosine
:View<x>:Modulation	W-CDMA
:View<x>:RefFilter	RaisedCosine
:View<x>:ShortCode	0
:View<x>:Source	Active
:View<x>:SymbolConstellation	Off



**Table B-19: Factory initialization settings — CodeWPolar View commands (3086 option 16 only) (Cont.)**

Header	Default settings
:View<x>:SymbolRate	4.096 MHz
:View<x>:TimeSlot	0

**Table B-20: Factory initialization settings — CodeWPower View commands (3086 option 16 only)**

Header	Default settings
:View<x>:Average	Off
:View<x>:Average:BeginZ	0
:View<x>:Average:EndZ	0
:View<x>:Average:Times	10
:View<x>:Average:Type	RMSExpo
:View<x>:Marker:DeltaMarker	Off
:View<x>:Marker:SearchSeparation	2 %
:View<x>:Marker:X	0
:View<x>:Scale:XScale	1
:View<x>:Scale:XStart	0
:View<x>:Scale:YScale	50
:View<x>:Scale:YStart	-50
:View<x>:ShortCode	0
:View<x>:SymbolRate	Composite
:View<x>:ZAxis	ShortCode
:View<x>:Z	0

**Table B-21: Factory initialization settings — CCDF commands (option 20 only)**

Header	Default settings
:View<x>:BeginZ	0
:View<x>:Destination	D1
:View<x>:EndZ	0
:View<x>:Marker:DeltaMarker	Off

**Table B-21: Factory initialization settings — CCDF commands (option 20 only) (Cont.)**

Header	Default settings
:View<x>:Marker:SearchSeparation	2 %
:View<x>:Marker:X	0
:View<x>:OutputFormat	CCDF
:View<x>:Position	100 %
:View<x>:Resolution	0.1
:View<x>:Scale:HoldYScale	Off
:View<x>:Scale:XScale	1
:View<x>:Scale:XStart	0
:View<x>:Scale:XStartZero	Off
:View<x>:Scale:YScale	0
:View<x>:Scale:YStart	0
:View<x>:Source	Active
:View<x>:Z	0

**Table B-22: Factory initialization settings — CCDFView commands (option 20 only)**

Header	Default settings
:View<x>:Marker:DeltaMarker	Off
:View<x>:Marker:SearchSeparation	2 %
:View<x>:Marker:X	0
:View<x>:Scale:XScale	1
:View<x>:Scale:XStart	0
:View<x>:Source	Active

## Utility Commands

**Table B-23: Factory initialization settings — Self gain-calibration commands**

Header	Default settings
:Util1:Gain:Auto	On

**Table B-24: Factory initialization settings — Save/Load commands**

Header	Default settings
:Util2:BeginZ	0
:Util2:EndZ	0
:Util2:Source	Active

**Table B-25: Factory initialization settings — Average commands**

Header	Default settings
:Util3:BeginZ	0
:Util3:Destination	D1
:Util3:EndZ	0
:Util3:Source	Active

**Table B-26: Factory initialization settings — Remote commands**

Header	Default settings
:Util8:Format	FreqAmpl
:Util8:GPIB:Interface	Off
:Util8:GPIB:PrimaryAddress	1
:Util8:Header	Off
:Util8:NewLine	CRLF
[:Util8]:NumericOutput	Exp
[:Util8]:Source	Active
[:Util8]:TCPIP:Port:Command	3066
[:Util8]:TCPIP:Port:Event	3067
[:Util8]:Z	0

## :Config:Mode Command

The :Config:Mode command (refer to page 2–40) overwrites the above default values as shown in Table B–27 and B–28, depending on its arguments.

**Table B–27: Factory initialization settings — :Config:Mode command – 1**

	<b>Freq1</b>	<b>Freq2</b>	<b>Dual</b>	<b>Zoom</b>
<b>View style</b>	1 × 1	1 × 2	1 × 4	2 × 2
<b>Setup</b>	Standard	Standard	Standard	Standard
<b>View1</b>	Waveform	Waveform	Waveform	Waveform
<b>View2</b>	–	Spectrogram	Spectrogram	Spectrogram
<b>View3</b>	–	–	Waveform (Time vs I)	Waveform
<b>View4</b>			Waveform (Time vs Q)	Spectrogram
<b>View5 – View8</b>	None	None	None	None
<b>Trigger mode</b>	Auto	Auto	Auto	Auto
<b>Memory mode</b>	Frequency	Frequency	Dual	Zoom

Table B-28: Factory initialization settings — :Config:Mode command – 2

	opCDMA1	opCDMA2	opCDMA3	opCDMA4	opCDMA5	opCDMA6	opDemod1
<b>View style</b>	2 × 2	1 × 2	1 × 2	2 × 2	1 × 2	1 × 2	2 × 2
<b>Setup</b>	CDMA	CDMA	CDMA	CDMA	CDMA	CDMA	Standard
<b>View1</b>	CDMA Waveform	CDMA Waveform	CDMA Time	CDMA Waveform	CDMA Waveform	CDMA Time	Waveform
Hor. Start	0			0			0
Position	50 %	50 %		50 %	50 %		
Measurement	Power	Spurious		Power	Spurious		
<b>View2</b>	Spectrogram	CDMA Waveform	CDMA Time	Spectrogram	CDMA Waveform	CDMA Time	Spectrogram
Position		50 %			50 %		
Measurement		Spurious			Spurious		
<b>View3</b>	CDMA Polar	None	None	CDMA Polar	None	None	Polar
Position	50 %			50 %			
<b>View4</b>	EVM	None	None	EVM	None	None	Eye diagram
<b>View5 – View8</b>	None	None	None	None	None	None	None
<b>Standard</b>	IS-95	IS-95	IS-95	T-53	T-53	T-53	
<b>Span</b>	5 MHz	30 MHz	5 MHz	5 MHz	30 MHz	5 MHz	
<b>Trigger mode</b>	Auto		Normal	Auto		Normal	
<b>Memory mode</b>							Dual
<b>Input mode</b>	RF	RF	RF	RF	RF	RF	

**Table B-29: Factory initialization settings —  
:Config:Mode command  
(3066 option 15 and 3086 option 16 only)**

	opCode1 <sup>1</sup>	opCodeW1 <sup>2</sup>
<b>View style</b>	2 × 2	2 × 2
<b>Setup</b>	Standard	Standard
<b>View1</b>	Waveform	Waveform
<b>View2</b>	CodeSpectrogram	CodeWSpectrogram
<b>View3</b>	CodePolar	CodeWPolar
<b>View4</b>	CodePower	CodeWPower
<b>View5 – View8</b>	None	None
<b>Span</b>	5 MHz	10 MHz
<b>Trigger mode</b>	Auto	Auto
<b>Memory mode</b>	Zoom	
<b>Input mode</b>	RF	Wideband

<sup>1</sup> 3066 option 15 and 3086 option 16 only.

<sup>2</sup> 3066 option 15 only.

**Table B-30: Factory initialization settings —  
:Config:Mode command (option 20 only)**

	opCCDF
<b>View7</b>	CCDF
<b>View8</b>	CCDFView

# **Glossary and Index**





# Glossary

**Amplitude Modulation (AM)**

The process, or result of a process, in which the amplitude of a sine wave (the carrier) is varied in accordance with the instantaneous voltage of a second electrical signal (the modulating signal).

**Bin**

A sample point in frequency domain. The frequency bandwidth of a bin is the span divided by the number of bins.

**BNF (Backus-Naur Form)**

A standard notation system for command syntax.

**Block**

A group of the specified number of frames.

**Carrier Frequency**

The frequency of the carrier signal.

**Carrier-to-Noise Ratio (C/N)**

The ratio of carrier signal power to average noise power in a given bandwidth surrounding the carrier; usually expressed in decibels.

**Center Frequency**

That frequency which corresponds to the center of a frequency span, expressed in hertz.

**dBm**

A unit of expressed power level in decibels referenced to 1 milliwatt.

**Decibel (dB)**

Ten times the logarithm of the ratio of one electrical power to another.

**Display Reference Level**

A designated vertical position representing a specified input level. The level may be expressed in dBm, volts, or any other units.

**EVM**

Acronym for the Error Vector Magnitude.

**Frame**

An area reserved in memory with the length represented by the number of FFT points. The analyzer acquires data in one frame by one scan in realtime mode.

**Filter**

A circuit which separates electrical signals or signal components based on their frequencies.

**Frequency Band**

The continuous range of frequencies extending between two limiting frequencies, expressed in hertz.

**Frequency Domain Representation**

The portrayal of a signal in the frequency domain; representing a signal by displaying its sine wave components; the signal spectrum.

**Frequency Modulation (FM)**

The process, or result of a process, in which the frequency of an electrical signal (the carrier) is varied in accordance with some characteristic of a second electrical signal (the modulating signal or modulation).

**Frequency Range**

That range of frequencies over which the performance of the instrument is specified.

**Frequency Response**

The unwanted variation in the displayed amplitude over a specified center frequency range, measured at the center frequency expressed in decibels.

**Frequency Span (Dispersion)**

The magnitude of the frequency band displayed; expressed in hertz or hertz per division.

**Full Span (Maximum Span)**

A mode of operation in which the spectrum analyzer scans an entire frequency band.

**Markers**

When the Marker function is enabled, it provides a movable cursor with readout of frequency and amplitude at the marker position. When the delta marker mode is enabled, a second marker allows operations and readout between the two marker positions.

**Peak Hold**

Digitally stored display mode which, at each frequency address, compares the incoming signal level to the stored level and retains the greater. In this mode, the display indicates the peak level at each frequency after several successive sweeps.

**MAX/MIN**

A display mode on the spectrum analyzer that shows the maximum and minimum signal levels at alternate frequency points; its advantage is its resemblance to an analog display.

**MIN Hold**

A spectrum analyzer feature which captures the minimum signal amplitude at all displayed frequencies over a series of sweeps.

**Modulate**

To regulate or vary a characteristic of a signal.

**Modulating Signal**

The signal which modulates a carrier. The signal which varies or regulates some characteristic of another signal.

**Modulation**

The process of varying some characteristic of a signal with a second signal.

**Peak Detection**

A detection scheme wherein the peak amplitude of a signal is measured and displayed. In spectrum analysis, 20 log (peak) is often displayed.

**Reference Level**

The signal level required to deflect the CRT display to the top graticule line.

**Resolution Bandwidth (RBW)**

The width of the narrowest filter in the IF stages of a spectrum analyzer. The RBW determines how well the analyzer can resolve or separate two or more closely spaced signal components.

**Span Per Division, Span/Div**

Frequency difference represented by each major horizontal division of the graticule.

**Spurious Response**

A response to a spectrum analyzer wherein the displayed frequency is not related to the input frequency.

**Vertical Scale Factor, Vertical Display Factor**

The number of dB, volts, etc., represented by one vertical division of a spectrum analyzer display screen.

**View (Display)**

Enables viewing of contents of the chosen memory section (e.g., "View A" displays the contents of memory A; "View B" displays the contents of memory B).



# Index

## A

abbreviations, commands, queries, and parameters, 2–4

Analog View commands

- :View<x>:CopyTo, 2–120
- :View<x>:Format (?), 2–120
- :View<x>:Marker:DeltaMarker (?), 2–121
- :View<x>:Marker:DeltaX?, 2–121
- :View<x>:Marker:DeltaY?, 2–122
- :View<x>:Marker:Peak, 2–122
- :View<x>:Marker:ResetDelta, 2–123
- :View<x>:Marker:SearchMax, 2–123
- :View<x>:Marker:SearchMin, 2–124
- :View<x>:Marker:SearchSeparation (?), 2–124
- :View<x>:Marker:X (?), 2–125
- :View<x>:Marker:Y?, 2–125
- :View<x>:Scale:AutoScale, 2–126
- :View<x>:Scale:HoldYScale (?), 2–126
- :View<x>:Scale:XScale (?), 2–127
- :View<x>:Scale:XStart (?), 2–127
- :View<x>:Scale:YScale (?), 2–128
- :View<x>:Scale:YStart (?), 2–128
- :View<x>:Source (?), 2–129
- :View<x>:Version?, 2–129
- :View<x>:Z (?), 2–130

Average commands

- :Util3:AllFrames, 2–376
- :Util3:BeginZ (?), 2–376
- :Util3:Destination (?), 2–376
- :Util3:EndZ (?), 2–377
- :Util3:MarkerToFrame, 2–377
- :Util3:PeakHold, 2–378
- :Util3:RMS, 2–379
- :Util3:Source (?), 2–380
- :Util3:Version?, 2–380

## B

Backus-Naur Form (BNF), 2–1

## C

case sensitivity, 2–5

CCDF commands

- :View<x>:AllFrames (?), 2–332
- :View<x>:Average:Reset, 2–332
- :View<x>:BeginZ (?), 2–333
- :View<x>:Destination (?), 2–333
- :View<x>:EndZ (?), 2–334

- :View<x>:Execute, 2–334
- :View<x>:Marker:DeltaMarker (?), 2–335
- :View<x>:Marker:ResetDelta, 2–335
- :View<x>:Marker:SearchMax, 2–336
- :View<x>:Marker:SearchMin, 2–336
- :View<x>:Marker:SearchSeparation (?), 2–337
- :View<x>:Marker:X (?), 2–337
- :View<x>:MarkerToFrame, 2–338
- :View<x>:OutputFormat (?), 2–338
- :View<x>:Position (?), 2–339
- :View<x>:Resolution (?), 2–339
- :View<x>:Result1?, 2–340
- :View<x>:Result2?, 2–340
- :View<x>:Result3?, 2–341
- :View<x>:Scale:AutoScale, 2–341
- :View<x>:Scale:HoldYScale (?), 2–342
- :View<x>:Scale:Origin (?), 2–342
- :View<x>:Scale:XScale (?), 2–343
- :View<x>:Scale:XStart (?), 2–343
- :View<x>:Scale:XStartZero (?), 2–344
- :View<x>:Scale:YScale (?), 2–344
- :View<x>:Scale:YStart (?), 2–345
- :View<x>:Source (?), 2–345
- :View<x>:Version?, 2–346
- :View<x>:Z (?), 2–346

CCDFView commands

- :View<x>:CopyFrom, 2–348
- :View<x>:CopyTo, 2–348
- :View<x>:Marker:DeltaMarker (?), 2–349
- :View<x>:Marker:ResetDelta, 2–349
- :View<x>:Marker:SearchMax, 2–350
- :View<x>:Marker:SearchMin, 2–350
- :View<x>:Marker:SearchSeparation (?), 2–351
- :View<x>:Marker:X (?), 2–351
- :View<x>:Scale:AutoScale, 2–352
- :View<x>:Scale:LYStart (?), 2–352
- :View<x>:Scale:LYStop (?), 2–353
- :View<x>:Scale:XScale (?), 2–353, 2–354
- :View<x>:Scale:XStart (?), 2–354
- :View<x>:Source (?), 2–355
- :View<x>:Version?, 2–355

CDMA Polar View commands

- :View<x>:AlphaBT (?), 2–230
- :View<x>:AutoCarrier (?), 2–230
- :View<x>:Burst:BlockSize (?), 2–231
- :View<x>:Burst:NumberFrames (?), 2–231
- :View<x>:Burst:Offset (?), 2–232
- :View<x>:Burst:Search (?), 2–233
- :View<x>:Burst:Threshold (?), 2–233
- :View<x>:Carrier (?), 2–234

- :View<x>:Display (?), 2-234
- :View<x>:Format (?), 2-235
- :View<x>:Marker:A?, 2-235
- :View<x>:Marker:DeltaT (?), 2-236
- :View<x>:Marker:P?, 2-236
- :View<x>:Marker:T (?), 2-236
- :View<x>:Marker:X?, 2-237
- :View<x>:Marker:Y?, 2-237
- :View<x>:MeasDestination (?), 2-238
- :View<x>:MeasFilter (?), 2-238
- :View<x>:Modulation (?), 2-239
- :View<x>:Position (?), 2-239
- :View<x>:RefDestination (?), 2-240
- :View<x>:RefFilter (?), 2-240
- :View<x>:Result<y>?, 2-241
- :View<x>:Source (?), 2-241
- :View<x>:Standard:CDPD, 2-242
- :View<x>:Standard:GSM, 2-242
- :View<x>:Standard:IS95, 2-242
- :View<x>:Standard:NADC, 2-243
- :View<x>:Standard:PDC, 2-243
- :View<x>:Standard:PHS, 2-243
- :View<x>:Standard:TETRA, 2-244
- :View<x>:SymbolRate (?), 2-244
- :View<x>:Version?, 2-244
- :View<x>:Z (?), 2-245
- CDMA Setup commands
  - :Setup:BlockSize (?), 2-78
  - :Setup:CDMA:Channel (?), 2-79
  - :Setup:CDMA:Span30M, 2-79
  - :Setup:CDMA:Span50M, 2-80
  - :Setup:CDMA:Span5MAuto, 2-80
  - :Setup:CDMA:Span5MNormal, 2-81
  - :Setup:CDMA:Standard (?), 2-81
  - :Setup:CDMA:TriggerLevel (?), 2-82
  - :Setup:MarkerToFreq, 2-82
  - :Setup:MaxSpan, 2-82
  - :Setup:ReferenceLevel (?), 2-83
  - :Setup:ReferenceOsc (?), 2-83
  - :Setup:Span (?), 2-84
  - :Setup:Trigger (?), 2-85
  - :Setup:TriggerCount (?), 2-86
  - :Setup:TriggerDelayed (?), 2-86
  - :Setup:TriggerDomain (?), 2-87
  - :Setup:TriggerInterval (?), 2-87
  - :Setup:TriggerPosition (?), 2-88
  - :Setup:TriggerSlope (?), 2-88
  - :Setup:TriggerSource (?), 2-89
  - :Setup:TriggerTimeout (?), 2-89
  - :Setup:TriggerTimes (?), 2-90
  - :Setup:Version?, 2-90
- CDMA Time View commands
  - :View<x>:Average:Times (?), 2-248
- :View<x>:Block (?), 2-248
- :View<x>:BreakMeasure, 2-248
- :View<x>:BreakMeasureData, 2-249
- :View<x>:Executing?, 2-249
- :View<x>:Marker:DeltaMarker (?), 2-250
- :View<x>:Marker:DeltaX (?), 2-250
- :View<x>:Marker:DeltaY?, 2-251
- :View<x>:Marker:Peak, 2-251
- :View<x>:Marker:ResetDelta, 2-252
- :View<x>:Marker:SearchMax, 2-252
- :View<x>:Marker:SearchMin, 2-253
- :View<x>:Marker:SearchSeparation (?), 2-253
- :View<x>:Marker:X (?), 2-254
- :View<x>:Marker:Y?, 2-254
- :View<x>:Mask:OffLeft (?), 2-255
- :View<x>:Mask:OffLevel (?), 2-255
- :View<x>:Mask:OffRight (?), 2-256
- :View<x>:Mask:OnLeft (?), 2-257
- :View<x>:Mask:OnLevel (?), 2-257
- :View<x>:Mask:OnRight (?), 2-258
- :View<x>:Measure, 2-259
- :View<x>:MeasureData, 2-259
- :View<x>:Position (?), 2-260
- :View<x>:Result<y>?, 2-260
- :View<x>:Scale:FallingEdge, 2-261
- :View<x>:Scale:FullScale, 2-261
- :View<x>:Scale:HoldYScale (?), 2-262
- :View<x>:Scale:RisingEdge, 2-262
- :View<x>:Scale:XScale (?), 2-263
- :View<x>:Scale:XStart (?), 2-263
- :View<x>:Scale:YScale (?), 2-264
- :View<x>:Scale:YStart (?), 2-264
- :View<x>:Source (?), 2-265
- :View<x>:Trace2:TraceVisible (?), 2-265
- :View<x>:TraceVisible (?), 2-266
- :View<x>:Version?, 2-266
- CDMA Waveform View commands
  - :View<x>:Average:Times (?), 2-208
  - :View<x>:Average:Type (?), 2-208
  - :View<x>:CDMA:Channel (?), 2-208
  - :View<x>:Compression (?), 2-209
  - :View<x>:CopyFrom, 2-210
  - :View<x>:CopyTo, 2-210
  - :View<x>:Format (?), 2-210
  - :View<x>:Marker:DeltaMarker (?), 2-211
  - :View<x>:Marker:DeltaX (?), 2-212
  - :View<x>:Marker:DeltaY?, 2-212
  - :View<x>:Marker:Peak, 2-213
  - :View<x>:Marker:ResetDelta, 2-213
  - :View<x>:Marker:SearchMax, 2-214
  - :View<x>:Marker:SearchMin, 2-214
  - :View<x>:Marker:SearchSeparation (?), 2-214
  - :View<x>:Marker:X (?), 2-215

- :View<x>:Marker:Y?, 2–215
- :View<x>:Mask:RBW1M:Frequency (?), 2–216
- :View<x>:Mask:RBW1M:Level (?), 2–216
- :View<x>:Mask:RBW30k:Frequency1 (?), 2–217
- :View<x>:Mask:RBW30k:Frequency2 (?), 2–217
- :View<x>:Mask:RBW30k:Level1 (?), 2–218
- :View<x>:Mask:RBW30k:Level2 (?), 2–218
- :View<x>:Measurement (?), 2–219
- :View<x>:Measurement:OBW (?), 2–219
- :View<x>:Measurement:Separation (?), 2–220
- :View<x>:Measurement:SortedBy (?), 2–220
- :View<x>:Measurement:SpuriousSearch (?), 2–221
- :View<x>:Measurement:Threshold (?), 2–221
- :View<x>:Position (?), 2–222
- :View<x>:RBW (?), 2–222
- :View<x>:Result<y>?, 2–223
- :View<x>:Scale:AutoScale, 2–224
- :View<x>:Scale:HoldYScale (?), 2–224
- :View<x>:Scale:XScale (?), 2–225
- :View<x>:Scale:XStart (?), 2–225
- :View<x>:Scale:YScale (?), 2–226
- :View<x>:Scale:YStart (?), 2–226
- :View<x>:Source (?), 2–227
- :View<x>:Version?, 2–228
- :View<x>:Z (?), 2–228
- chaining commands and queries, 2–4
- character chart, A–I
- :Clipboard?, 2–382
- CodePolar View commands
  - :View<x>:AlphaBT (?), 2–278
  - :View<x>:Analysis:TimeSlot (?), 2–278
  - :View<x>:Analyze (?), 2–278
  - :View<x>:AutoCarrier (?), 2–279
  - :View<x>:BreakAnalyze (?), 2–279
  - :View<x>:Carrier (?), 2–280
  - :View<x>:Display (?), 2–280
  - :View<x>:Format (?), 2–281
  - :View<x>:Marker:T (?), 2–281
  - :View<x>:MeasFilter (?), 2–282
  - :View<x>:Modulation (?), 2–282
  - :View<x>:RefFilter (?), 2–283
  - :View<x>:Source (?), 2–283
  - :View<x>:Standard:IS95EQ, 2–284
  - :View<x>:SymbolRate (?), 2–285
  - :View<x>:Version?, 2–285
- CodePower View commands
  - :View<x>:Average (?), 2–288
  - :View<x>:Average:AllFrames (?), 2–288
  - :View<x>:Average:BeginZ (?), 2–289
  - :View<x>:Average:EndZ (?), 2–289
  - :View<x>:Average:Execute, 2–290
  - :View<x>:AverageMarkerToFrame, 2–290
  - :View<x>:Average:Times (?), 2–291
  - :View<x>:Average:Type (?), 2–291
  - :View<x>:Marker:DeltaMarker (?), 2–292
  - :View<x>:Marker:ResetDelta, 2–292
  - :View<x>:Marker:SearchMax, 2–292
  - :View<x>:Marker:SearchMin, 2–293
  - :View<x>:Marker:SearchSeparation (?), 2–293
  - :View<x>:Marker:X (?), 2–294
  - :View<x>:Scale:AutoScale, 2–294
  - :View<x>:Scale:XScale (?), 2–295
  - :View<x>:Scale:XStart (?), 2–295
  - :View<x>:Scale:YScale (?), 2–296
  - :View<x>:Scale:YStart (?), 2–296
  - :View<x>:Version?, 2–297
  - :View<x>:Z (?), 2–297
- CodeSpectrogram View commands
  - :View<x>:Marker:DeltaMarker (?), 2–268
  - :View<x>:Marker:ResetDelta, 2–268
  - :View<x>:Marker:SearchMax, 2–269
  - :View<x>:Marker:SearchMin, 2–269
  - :View<x>:Marker:SearchSeparation (?), 2–270
  - :View<x>:Marker:X (?), 2–270
  - :View<x>:Marker:Z (?), 2–271
  - :View<x>:Monochrome (?), 2–271
  - :View<x>:NumberColors (?), 2–272
  - :View<x>:Scale:AutoScale, 2–272
  - :View<x>:Scale:XScale (?), 2–273
  - :View<x>:Scale:XStart (?), 2–273
  - :View<x>:Scale:YScale (?), 2–274
  - :View<x>:Scale:YStart (?), 2–274
  - :View<x>:Scale:ZScale (?), 2–275
  - :View<x>:Scale:ZStart (?), 2–275
  - :View<x>:Version?, 2–276
  - :View<x>:ZGap (?), 2–276
- CodeWPolar View commands
  - :View<x>:AlphaBT (?), 2–310
  - :View<x>:Analysis:TimeSlot (?), 2–310
  - :View<x>:Analyze (?), 2–310
  - :View<x>:AutoCarrier (?), 2–311
  - :View<x>:BreakAnalyze (?), 2–311
  - :View<x>:Carrier (?), 2–312
  - :View<x>:Display (?), 2–312
  - :View<x>:Format (?), 2–313
  - :View<x>:Marker:T (?), 2–313
  - :View<x>:MeasFilter (?), 2–314
  - :View<x>:Modulation (?), 2–314
  - :View<x>:RefFilter (?), 2–315
  - :View<x>:ShortCode (?), 2–315
  - :View<x>:Source (?), 2–316
  - :View<x>:Standard:WCDMA16M, 2–316
  - :View<x>:Standard:WCDMA4M, 2–316
  - :View<x>:Standard:WCDMA8M, 2–317
  - :View<x>:SymbolConstellation (?), 2–317
  - :View<x>:SymbolRate (?), 2–318

- :View<x>:TimeSlot (?), 2–318
- :View<x>:Version?, 2–318
- CodeWPower View commands
  - :View<x>:Average (?), 2–320
  - :View<x>:Average:AllFrames (?), 2–320
  - :View<x>:Average:BeginZ (?), 2–321
  - :View<x>:Average:EndZ (?), 2–321
  - :View<x>:Average:Execute, 2–322
  - :View<x>:Average:MarkerToFrame, 2–322
  - :View<x>:Average:Times (?), 2–323
  - :View<x>:Average:Type (?), 2–323
  - :View<x>:Marker:DeltaMarker (?), 2–324
  - :View<x>:Marker:ResetDelta, 2–324
  - :View<x>:Marker:SearchMax, 2–324
  - :View<x>:Marker:SearchMin, 2–325
  - :View<x>:Marker:SearchSeparation (?), 2–325
  - :View<x>:Marker:X (?), 2–326
  - :View<x>:Scale:AutoScale, 2–326
  - :View<x>:Scale:XScale (?), 2–327
  - :View<x>:Scale:XStart (?), 2–327
  - :View<x>:Scale:YScale (?), 2–328
  - :View<x>:Scale:YStart (?), 2–328
  - :View<x>:ShortCode (?), 2–328
  - :View<x>:SymbolRate (?), 2–329
  - :View<x>:Version?, 2–329
  - :View<x>:XAxis (?), 2–330
  - :View<x>:Z (?), 2–330
- CodeWSpectrogram View commands
  - :View<x>:Marker:DeltaMarker (?), 2–300
  - :View<x>:Marker:ResetDelta, 2–300
  - :View<x>:Marker:SearchMax, 2–301
  - :View<x>:Marker:SearchMin, 2–301
  - :View<x>:Marker:SearchSeparation (?), 2–302
  - :View<x>:Marker:X (?), 2–302
  - :View<x>:Marker:Z (?), 2–303
  - :View<x>:Monochrome (?), 2–303
  - :View<x>:NumberColors (?), 2–304
  - :View<x>:Scale:AutoScale, 2–304
  - :View<x>:Scale:XScale (?), 2–305
  - :View<x>:Scale:XStart (?), 2–305
  - :View<x>:Scale:YScale (?), 2–306
  - :View<x>:Scale:YStart (?), 2–306
  - :View<x>:Scale:ZScale (?), 2–307
  - :View<x>:Scale:ZStart (?), 2–307
  - :View<x>:SymbolRate (?), 2–308
  - :View<x>:Version?, 2–308
  - :View<x>:ZGap (?), 2–308
- command
  - chaining, 2–4
  - creating, 2–2
  - groups, 2–7
  - parts, 1–2
  - port, 1–6
  - syntax, 2–1
- communication
  - ports, 1–5
  - setting parameters, 1–7
- :Config:Block, 2–38
- :Config:Continue, 2–38
- :Config:Label, 2–39
- :Config:Message, 2–39
- :Config:Mode, 2–40
- :Config:Mode:Load, 2–41
- :Config:Mode:Save, 2–41
- :Config:Next, 2–42
- :Config:Pause (?), 2–42
- :Config:PrintScreen, 2–43
- :Config:PrintScreen:Printer, 2–43
- :Config:PrintScreen:Printer:Items, 2–44
- :Config:PrintScreen:Printer:Save, 2–44
- :Config:PrintScreen:Save, 2–44
- :Config:Roll, 2–45
- :Config:Setup (?), 2–45
- :Config:Setup:Items, 2–46
- :Config:Setup:Show, 2–46
- :Config:Start, 2–47
- :Config:StartAgain, 2–47
- :Config:Status:Overload?, 2–48
- :Config:Status:Pause?, 2–48
- :Config:Status:Triggered?, 2–49
- :Config:Status:Uncal?, 2–49
- :Config:Stop, 2–50
- :Config:System?, 2–50
- :Config:Util:Items?, 2–51
- :Config:Util<x> (?), 2–51
- :Config:Util<x>:Show, 2–52
- :Config:Version?, 2–52
- :Config:View:BackgroundColor (?), 2–53
- :Config:View:Items?, 2–53
- :Config:View:MarkerLink (?), 2–54
- :Config:View:Style (?), 2–54
- :Config:View<x> (?), 2–54
- :Config:View<x>:Show (?), 2–56
- Configuration commands
  - :Config:Block, 2–38
  - :Config:Continue, 2–38
  - :Config:Label, 2–39
  - :Config:Message, 2–39
  - :Config:Mode, 2–40
  - :Config:Mode:Load, 2–41
  - :Config:Mode:Save, 2–41
  - :Config:Next, 2–42
  - :Config:Pause (?), 2–42
  - :Config:PrintScreen, 2–43
  - :Config:PrintScreen:Printer (?), 2–43
  - :Config:PrintScreen:Printer:Items, 2–44
  - :Config:PrintScreen:Printer:Save, 2–44



- :Config:Roll, 2–45
- :Config:Setup (?), 2–45
- :Config:Setup:Items, 2–46
- :Config:Setup:Show, 2–46
- :Config:Start, 2–47
- :Config:StartAgain, 2–47
- :Config:Status:Overload?, 2–48
- :Config:Status:Pause?, 2–48
- :Config:Status:Triggered?, 2–49
- :Config:Status:Uncal?, 2–49
- :Config:Stop, 2–50
- :Config:System?, 2–50
- :Config:Util:Items?, 2–51
- :Config:Util<x> (?), 2–51
- :Config:Util<x>:Show, 2–52
- :Config:Version?, 2–52
- :Config:View:BackgroundColor (?), 2–53
- :Config:View:Items?, 2–53
- :Config:View:MarkerLink (?), 2–54
- :Config:View:Style (?), 2–54
- :Config:View<x> (?), 2–54
- :Config:View<x>:Show (?), 2–56

connecting the interface, 1–4

constructed mnemonics, 2–6

creating commands, 2–2

creating queries, 2–2

## D

Difference between the 3066 and 3086, 1–1

## E

error, messages, 3–4

Ethernet interface, 1–4

event, 3–1

- messages, 3–3
- port, 1–6, 3–1

EVM View commands

- :View<x>:Symbol (?), 2–206
- :View<x>:CopyTo, 2–198
- :View<x>:Format (?), 2–198
- :View<x>:Marker:DeltaMarker (?), 2–199
- :View<x>:Marker:DeltaX (?), 2–199
- :View<x>:Marker:DeltaY?, 2–200
- :View<x>:Marker:ResetDelta, 2–200
- :View<x>:Marker:SearchMax, 2–200
- :View<x>:Marker:SearchMin, 2–201
- :View<x>:Marker:X (?), 2–201
- :View<x>:Marker:Y?, 2–202
- :View<x>:MaskArea (?), 2–202

- :View<x>:Result<y>?, 2–203
- :View<x>:Scale:AutoScale, 2–203
- :View<x>:Scale:XScale (?), 2–204
- :View<x>:Scale:XStart (?), 2–204
- :View<x>:Scale:YScale (?), 2–205
- :View<x>:Scale:YStart (?), 2–205
- :View<x>:Version?, 2–206

examples, programming, 4–1

Eye Diagram View commands

- :View<x>:EyeLength (?), 2–188
- :View<x>:Format (?), 2–188
- :View<x>:Marker:T (?), 2–189
- :View<x>:Marker:Y?, 2–189
- :View<x>:Source (?), 2–190
- :View<x>:Version?, 2–190

## F

factory initialization settings, B–1

FSK View commands

- :View<x>:CopyTo, 2–132
- :View<x>:Marker:DeltaMarker (?), 2–132
- :View<x>:Marker:DeltaX (?), 2–133
- :View<x>:Marker:DeltaY?, 2–133
- :View<x>:Marker:Peak, 2–134
- :View<x>:Marker:ResetDelta, 2–134
- :View<x>:Marker:SearchMax, 2–134
- :View<x>:Marker:SearchMin, 2–135
- :View<x>:Marker:SearchSeparation (?), 2–135
- :View<x>:Marker:X (?), 2–136
- :View<x>:Marker:Y?, 2–136
- :View<x>:Scale:AutoScale, 2–136
- :View<x>:Scale:HoldYScale (?), 2–137
- :View<x>:Scale:XScale (?), 2–137
- :View<x>:Scale:XStart (?), 2–138
- :View<x>:Scale:YScale (?), 2–138
- :View<x>:Scale:YStart (?), 2–139
- :View<x>:Source (?), 2–139
- :View<x>:Version?, 2–140
- :View<x>:Z (?), 2–140

functional groups, 2–8

## G

GPIB

- configurations, 1–6
- connection rules, 1–6
- interface, 1–4
- port, 1–5
- setting parameters, 1–8

**H**

headers in query responses, 2–3

**I**

initialization settings, B–1

interface

- connections, 1–4
- Ethernet, 1–4
- GPIO, 1–4

**M**

messages, 3–3

- error, 3–4
- event, 3–3
- obtaining, 3–1

mnemonics, constructed, 2–6

**P**

parameter types, 2–3

Parameter types used in syntax descriptions, 2–3

Polar View commands

- :View<x>:AlphaBT (?), 2–172
- :View<x>:AutoCarrier (?), 2–172
- :View<x>:Burst:BlockSize (?), 2–173
- :View<x>:Burst:NumberFrames (?), 2–173
- :View<x>:Burst:Offset (?), 2–174
- :View<x>:Burst:Search (?), 2–175
- :View<x>:Burst:Threshold (?), 2–175
- :View<x>:Carrier (?), 2–176
- :View<x>:Display (?), 2–176
- :View<x>:Format (?), 2–177
- :View<x>:Marker:A?, 2–177
- :View<x>:Marker:DeltaT (?), 2–178
- :View<x>:Marker:P?, 2–178
- :View<x>:Marker:T (?), 2–178
- :View<x>:Marker:X?, 2–179
- :View<x>:Marker:Y?, 2–179
- :View<x>:MeasDestination (?), 2–180
- :View<x>:MeasFilter (?), 2–180
- :View<x>:Modulation (?), 2–181
- :View<x>:Position (?), 2–181
- :View<x>:RefDestination (?), 2–182
- :View<x>:RefFilter (?), 2–182
- :View<x>:Result<y>?, 2–183
- :View<x>:Source (?), 2–183
- :View<x>:Standard:CDPD, 2–184

- :View<x>:Standard:GSM, 2–184
- :View<x>:Standard:IS95, 2–284
- :View<x>:Standard:NADC, 2–184
- :View<x>:Standard:PDC, 2–185
- :View<x>:Standard:PHS, 2–185
- :View<x>:Standard:TETRA, 2–185
- :View<x>:SymbolRate (?), 2–186
- :View<x>:Version?, 2–186
- :View<x>:Z (?), 2–186

port

- command, 1–6
- event, 1–6
- GPIO, 1–5
- TCP/IP, 1–6

programming examples, 4–1

**Q**

quotes, 2–5

**R**

Remote commands

- :Clipboard?, 2–382
- :Set?, 2–382
- [:Util8]:Dev<x>:<command>, 2–383
- [:Util8]:Error?, 2–383
- [:Util8]:Event:<message>, 2–384
- [:Util8]:Format (?), 2–384
- [:Util8]:GPIO:Interface (?), 2–385
- [:Util8]:GPIO:PrimaryAddress (?), 2–385
- [:Util8]:Header (?), 2–386
- [:Util8]:Id?, 2–386
- [:Util8]:Key, 2–387
- [:Util8]:NewLine (?), 2–388
- [:Util8]:NumericOutput (?), 2–388
- [:Util8]:Register:Data, 2–389
- [:Util8]:Register:Header, 2–390
- [:Util8]:Source (?), 2–391
- [:Util8]:Source:<item>?, 2–392
- [:Util8]:Status?, 2–394
- [:Util8]:TCPIP:Port:Command (?), 2–395
- [:Util8]:TCPIP:Port:Command:Reset, 2–395
- [:Util8]:TCPIP:Port:Event (?), 2–396
- [:Util8]:TCPIP:Port:Event:Reset, 2–396
- [:Util8]:Version?, 2–397
- [:Util8]:ViewName?, 2–397
- [:Util8]:Z (?), 2–397
- [:Util8]:Z:<item>?, 2–398

retrieving response message, 2–399

rules, for using commands, 2–5

## S

Save/Load commands

- :Util2:Buffer:<header> (?), 2–362
- :Util2:AllFrames, 2–362
- :Util2:BeginZ (?), 2–362
- :Util2:Buffer:CopyHeader, 2–364
- :Util2:Buffer:SaveHeader, 2–365
- :Util2:Data:Load, 2–365
- :Util2:Data:Save, 2–366
- :Util2:Data:SaveAP, 2–367
- :Util2:Data:Saved, 2–367
- :Util2:Data:SaveDateTime, 2–369
- :Util2:Data:SaveFlatness, 2–370
- :Util2:Data:SaveFrame, 2–371
- :Util2:Data:SaveHeader, 2–372
- :Util2:Data:SaveIQ, 2–368
- :Util2:EndZ (?), 2–373
- :Util2:MarkerToFrame, 2–373
- :Util2:Source (?), 2–374
- :Util2:Version?, 2–374

Self Gain-Calibration commands

- :Util1:Execute, 2–358
- :Util1:Gain:Auto, 2–358
- :Util1:Gain:Execute, 2–359
- :Util1:IQOffset:Execute, 2–359
- :Util1:Result<x>?, 2–360
- :Util1:Version?, 2–360
- :Util1:WidebandOffset:Request, 2–360

:Set?, 2–382

setting communication parameters, 1–7

:Setup:BlockSize (?)

- CDMA Setup, 2–78

- Standard Setup, 2–58

:Setup:CDMA:Channel (?), 2–79

:Setup:CDMA:Span30M, 2–79

:Setup:CDMA:Span50M, 2–80

:Setup:CDMA:Span5MAuto, 2–80

:Setup:CDMA:Span5MNormal, 2–81

:Setup:CDMA:Standard (?), 2–81

:Setup:CDMA:TriggerLevel (?), 2–82

:Setup:CenterFrequency (?), 2–59

:Setup:FFTPoints (?), 2–60

:Setup:FFTWindow (?), 2–60

:Setup:FramePeriod (?), 2–61

:Setup:FrequencyOffset (?), 2–61

:Setup:InputCoupling (?), 2–62

:Setup:InputMode (?), 2–63

:Setup:LevelOffset (?), 2–63

:Setup:Load, Standard Setup, 2–64

:Setup:MarkerToFreq

- CDMA Setup, 2–82

- Standard Setup, 2–64

:Setup:MaxSpan

- CDMA Setup, 2–82

- Standard Setup, 2–65

:Setup:MemoryMode (?), 2–65

:Setup:ReferenceLevel (?)

- CDMA Setup, 2–83

- Standard Setup, 2–66

:Setup:ReferenceOsc (?)

- CDMA Setup, 2–83

- Standard Setup, 2–67

:Setup:Save, Standard Setup, 2–67

:Setup:Span (?)

- CDMA Setup, 2–84

- Standard Setup, 2–68

:Setup:Trigger (?)

- CDMA Setup, 2–85

- Standard Setup, 2–68

:Setup:TriggerCount (?)

- CDMA Setup, 2–86

- Standard Setup, 2–70

:Setup:TriggerDelayed (?)

- CDMA Setup, 2–86

- Standard Setup, 2–70

:Setup:TriggerDomain (?)

- CDMA Setup, 2–87

- Standard Setup, 2–71

:Setup:TriggerInterval (?)

- CDMA Setup, 2–87

- Standard Setup, 2–71

:Setup:TriggerPosition (?)

- CDMA Setup, 2–88

- Standard Setup, 2–72

:Setup:TriggerSlope (?)

- CDMA Setup, 2–88

- Standard Setup, 2–72

:Setup:TriggerSource (?)

- CDMA Setup, 2–89

- Standard Setup, 2–73

:Setup:TriggerTimeout (?)

- CDMA Setup, 2–89

- Standard Setup, 2–73

:Setup:TriggerTimes (?)

- CDMA Setup, 2–90

- Standard Setup, 2–74

:Setup:Version?

- CDMA Setup, 2–90

- Standard Setup, 2–74

:Setup:Zoom:Execute, 2–75

:Setup:Zoom:Frequency (?), 2–75

- :Setup:Zoom:Mag (?), 2–76
  - SI prefix and unit, 2–5
  - special characters, 2–3
  - Spectrogram View commands
    - :View<x>:Compression (?), 2–142
    - :View<x>:Format (?), 2–142
    - :View<x>:Marker:DeltaMarker (?), 2–143
    - :View<x>:Marker:DeltaT?, 2–143
    - :View<x>:Marker:DeltaX?, 2–144
    - :View<x>:Marker:DeltaY?, 2–144
    - :View<x>:Marker:DeltaZ (?), 2–144
    - :View<x>:Marker:Peak, 2–145
    - :View<x>:Marker:ResetDelta, 2–145
    - :View<x>:Marker:SearchMax, 2–146
    - :View<x>:Marker:SearchMin, 2–146
    - :View<x>:Marker:SearchSeparation (?), 2–146
    - :View<x>:Marker:T?, 2–147
    - :View<x>:Marker:X (?), 2–147
    - :View<x>:Marker:Y?, 2–148
    - :View<x>:Marker:Z (?), 2–148
    - :View<x>:Monochrome (?), 2–148
    - :View<x>:NumberColors (?), 2–149
    - :View<x>:Scale:AutoScale, 2–149
    - :View<x>:Scale:HoldYScale (?), 2–150
    - :View<x>:Scale:XScale (?), 2–150
    - :View<x>:Scale:XStart (?), 2–151
    - :View<x>:Scale:YScale (?), 2–151
    - :View<x>:Scale:YStart (?), 2–152
    - :View<x>:Scale:ZScale (?), 2–152
    - :View<x>:Scale:ZStart (?), 2–153
    - :View<x>:Source (?), 2–153
    - :View<x>:Version?, 2–154
    - :View<x>:ZGap (?), 2–154
  - Standard Setup commands
    - :Setup:FFTWindow (?), 2–60
    - :Setup:BlockSize (?), 2–58
    - :Setup:CenterFrequency (?), 2–59
    - :Setup:FFTPoints (?), 2–60
    - :Setup:FramePeriod (?), 2–61
    - :Setup:FrequencyOffset (?), 2–61
    - :Setup:InputCoupling (?), 2–62
    - :Setup:InputMode (?), 2–63
    - :Setup:LevelOffset (?), 2–63
    - :Setup:Load, 2–64
    - :Setup:MarkerToFreq, 2–64
    - :Setup:MaxSpan, 2–65
    - :Setup:MemoryMode (?), 2–65
    - :Setup:ReferenceLevel (?), 2–66
    - :Setup:ReferenceOsc (?), 2–67
    - :Setup:Save, 2–67
    - :Setup:Span (?), 2–68
    - :Setup:Trigger (?), 2–68
    - :Setup:TriggerCount (?), 2–70
    - :Setup:TriggerDelayed (?), 2–70
    - :Setup:TriggerDomain (?), 2–71
    - :Setup:TriggerInterval (?), 2–71
    - :Setup:TriggerPosition (?), 2–72
    - :Setup:TriggerSlope (?), 2–72
    - :Setup:TriggerSource (?), 2–73
    - :Setup:TriggerTimeout (?), 2–73
    - :Setup:TriggerTimes (?), 2–74
    - :Setup:Version?, 2–74
    - :Setup:Zoom:Execute, 2–75
    - :Setup:Zoom:Frequency (?), 2–75
    - :Setup:Zoom:Mag (?), 2–76
  - status, 3–1
  - Status Byte Register, 3–2
  - Symbol Table View commands
    - :View<x>:Symbol (?), 2–195
    - :View<x>:CopyTo, 2–192
    - :View<x>:Marker:Data?, 2–192
    - :View<x>:Marker:Symbol?, 2–193
    - :View<x>:Marker:T (?), 2–193
    - :View<x>:Radix (?), 2–194
    - :View<x>:Rotate (?), 2–194
    - :View<x>:Source (?), 2–195
    - :View<x>:Version?, 2–196
  - syntax, command, 2–1
- ## T
- TCP/IP
    - event port, 3–1
    - port, 1–6
    - setting parameters, 1–9
- ## U
- unit and SI prefix, 2–5
  - :Util1:Execute, 2–358
  - :Util1:Gain:Auto, 2–358
  - :Util1:Gain:Execute, 2–359
  - :Util1:IQOffset:Execute, 2–359
  - :Util1:Result<x>?, 2–360
  - :Util1:Version?, 2–360
  - :Util1:WideOffset:Request, 2–360
  - :Util2:AllFrames, 2–362
  - :Util2:BeginZ (?), 2–362
  - :Util2:Buffer:<header> (?), 2–362
  - :Util2:Buffer:CopyHeader, 2–364
  - :Util2:Buffer:SaveHeader, 2–365
  - :Util2:Data:Load, 2–365
  - :Util2:Data:Save, 2–366
  - :Util2:Data:SaveAP, 2–367
  - :Util2:Data:Saved, 2–367

:Util2:Data:SaveDateTime, 2–369  
 :Util2:Data:SaveFlatness, 2–370  
 :Util2:Data:SaveFrame, 2–371  
 :Util2:Data:SaveHeader, 2–372  
 :Util2:Data:SaveIQ, 2–368  
 :Util2:EndZ (?), 2–373  
 :Util2:MarkerToFrame, 2–373  
 :Util2:Source (?), 2–374  
 :Util2:Version?, 2–374  
 :Util3:AllFrames, 2–376  
 :Util3:BeginZ (?), 2–376  
 :Util3:Destination (?), 2–376  
 :Util3:EndZ (?), 2–377  
 :Util3:MarkerToFrame, 2–377  
 :Util3:PeakHold, 2–378  
 :Util3:RMS, 2–379  
 :Util3:Source (?), 2–380  
 :Util3:Version?, 2–380  
 [:Util8]:Dev<x>:<command>, 2–383  
 [:Util8]:Error?, 2–383  
 [:Util8]:Event:<message>, 2–384  
 [:Util8]:Format (?), 2–384  
 [:Util8]:GPIB:Interface (?), 2–385  
 [:Util8]:GPIB:PrimaryAddress (?), 2–385  
 [:Util8]:Header (?), 2–386  
 [:Util8]:Id?, 2–386  
 [:Util8]:Key, 2–387  
 [:Util8]:NewLine (?), 2–388  
 [:Util8]:NumericOutput (?), 2–388  
 [:Util8]:Register:Data, 2–389  
 [:Util8]:Register:Header, 2–390  
 [:Util8]:Source (?), 2–391  
 [:Util8]:Source:<item>?, 2–392  
 [:Util8]:Status?, 2–394  
 [:Util8]:TCPIP:Port:Command (?), 2–395  
 [:Util8]:TCPIP:Port:Command:Reset, 2–395  
 [:Util8]:TCPIP:Port:Event (?), 2–396  
 [:Util8]:TCPIP:Port:Event:Reset, 2–396  
 [:Util8]:Version?, 2–397  
 [:Util8]:ViewName?, 2–397  
 [:Util8]:Z (?), 2–397  
 [:Util8]:Z:<item>?, 2–398

## V

:View<x>:Symbol (?)  
     EVM View, 2–206  
     Symbol Table View, 2–195  
 :View<x>:AllFrames (?), CCDF, 2–332  
 :View<x>:AlphaBT (?)  
     CDMA Polar View, 2–230  
     CodePolar View, 2–278  
     CodeWPolar View, 2–310  
     Polar View, 2–172  
 :View<x>:Analysis:TimeSlot (?)  
     CodePolar View, 2–278  
     CodeWPolar View, 2–310  
 :View<x>:Analyze (?)  
     CodePolar View, 2–278  
     CodeWPolar View, 2–310  
 :View<x>:AutoCarrier (?)  
     CDMA Polar View, 2–230  
     CodePolar View, 2–279  
     CodeWPolar View, 2–311  
     Polar View, 2–172  
 :View<x>:Average (?)  
     CodePower View, 2–288  
     CodeWPower View, 2–320  
 :View<x>:Average:AllFrames (?)  
     CodePower View, 2–288  
     CodeWPower View, 2–320  
 :View<x>:Average:BeginZ (?)  
     CodePower View, 2–289  
     CodeWPower View, 2–321  
 :View<x>:Average:EndZ (?)  
     CodePower View, 2–289  
     CodeWPower View, 2–321  
 :View<x>:Average:Execute  
     CodePower View, 2–290  
     CodeWPower View, 2–322  
 :View<x>:Average:MarkerToFrame  
     CodePower View, 2–290  
     CodeWPower View, 2–322  
 :View<x>:Average:Reset, CCDF, 2–332  
 :View<x>:Average:Times (?)  
     CDMA Time View, 2–248  
     CDMA Waveform View, 2–208  
     CodePower View, 2–291  
     CodeWPower View, 2–323  
     Waveform View, 2–92  
 :View<x>:Average:Type (?)  
     CDMA Waveform View, 2–208  
     CodePower View, 2–291  
     CodeWPower View, 2–323  
     Waveform View, 2–92  
 :View<x>:BeginZ (?), CCDF, 2–333  
 :View<x>:Block (?), CDMA Time View, 2–248  
 :View<x>:BreakAnalyze (?)  
     CodePolar View, 2–279  
     CodeWPolar View, 2–311  
 :View<x>:BreakMeasure, CDMA Time View, 2–248  
 :View<x>:BreakMeasureData, CDMA Time View,  
     2–249  
 :View<x>:Burst:BlockSize (?)

- CDMA Polar View, 2–231
- Polar View, 2–173
- :View<x>:Burst:NumberFrames (?)
  - CDMA Polar View, 2–231
  - Polar View, 2–173
- :View<x>:Burst:Offset (?)
  - CDMA Polar View, 2–232
  - Polar View, 2–174
- :View<x>:Burst:Search (?)
  - CDMA Polar View, 2–233
  - Polar View, 2–175
- :View<x>:Burst:Threshold (?)
  - CDMA Polar View, 2–233
  - Polar View, 2–175
- :View<x>:Carrier (?)
  - CDMA Polar View, 2–234
  - CodePolar View, 2–280
  - CodeWPolar View, 2–312
  - Polar View, 2–176
- :View<x>:CDMA:Channel (?), CDMA Waveform View, 2–208
- :View<x>:Compression (?)
  - CDMA Waveform View, 2–209
  - Spectrogram View, 2–142
  - Waterfall View, 2–156
  - Waveform View, 2–93
- :View<x>:CopyFrom
  - CCDFView, 2–348
  - CDMA Waveform View, 2–210
  - Waveform View, 2–93
- :View<x>:CopyTo
  - Analog View, 2–120
  - CCDFView, 2–348
  - CDMA Waveform View, 2–210
  - EVM View, 2–198
  - FSK View, 2–132
  - Symbol Table View, 2–192
  - Waveform View, 2–94
- :View<x>:Destination (?), CCDF, 2–333
- :View<x>:Display (?)
  - CDMA Polar View, 2–234
  - CodePolar View, 2–280
  - CodeWPolar View, 2–312
  - Polar View, 2–176
- :View<x>:Edit (?), Waveform View, 2–94
- :View<x>:Edit:DrawHorizontal, Waveform View, 2–95
- :View<x>:Edit:DrawLine, Waveform View, 2–95
- :View<x>:Edit:DrawMax, Waveform View, 2–96
- :View<x>:Edit:DrawMin, Waveform View, 2–96
- :View<x>:Edit:Y (?), Waveform View, 2–96
- :View<x>:EndZ (?), CCDF, 2–334
- :View<x>:Execute, CCDF, 2–334
- :View<x>:Executing?, CDMA Time View, 2–249
- :View<x>:EyeLength (?), Eye Diagram View, 2–188
- :View<x>:Format (?)
  - Analog View, 2–120
  - CDMA Polar View, 2–235
  - CDMA Waveform View, 2–210
  - CodePolar View, 2–281
  - CodeWPolar View, 2–313
  - EVM View, 2–198
  - Eye Diagram View, 2–188
  - Polar View, 2–177
  - Spectrogram View, 2–142
  - Waterfall View, 2–157
  - Waveform View, 2–97
- :View<x>:Marker:A?
  - CDMA Polar View, 2–235
  - Polar View, 2–177
- :View<x>:Marker:Band:Center (?), Waveform View, 2–98
- :View<x>:Marker:Band:Left (?), Waveform View, 2–98
- :View<x>:Marker:Band:Right (?), Waveform View, 2–99
- :View<x>:Marker:Band:Width (?), Waveform View, 2–99
- :View<x>:Marker:Data?, Symbol Table View, 2–192
- :View<x>:Marker:DeltaMarker (?)
  - Analog View, 2–121
  - CCDF, 2–335
  - CCDFView, 2–349
  - CDMA Time View, 2–250
  - CDMA Waveform View, 2–211
  - CodePower View, 2–292
  - CodeSpectrogram View, 2–268
  - CodeWPower View, 2–324
  - CodeWSpectrogram View, 2–300
  - EVM View, 2–199
  - FSK View, 2–132
  - Spectrogram View, 2–143
  - Waterfall View, 2–158
  - Waveform View, 2–100
- :View<x>:Marker:DeltaT (?)
  - CDMA Polar View, 2–236
  - Polar View, 2–178
- :View<x>:Marker:DeltaT?
  - Spectrogram View, 2–143
  - Waterfall View, 2–158
- :View<x>:Marker:DeltaX (?)
  - CDMA Time View, 2–250
  - CDMA Waveform View, 2–212
  - EVM View, 2–199
  - FSK View, 2–133
  - Waterfall View, 2–159
  - Waveform View, 2–100
- :View<x>:Marker:DeltaX?

- Spectrogram View, 2-144
- Waveform View, 2-121
- :View<x>:Marker:DeltaY?
  - CDMA Time View, 2-251
  - CDMA Waveform View, 2-212
  - EVM View, 2-200
  - FSK View, 2-133
  - Spectrogram View, 2-144
  - Waterfall View, 2-159
  - Waveform View, 2-101, 2-122
- :View<x>:Marker:DeltaZ (?)
  - Spectrogram View, 2-144
  - Waterfall View, 2-160
- :View<x>:Marker:P?
  - CDMA Polar View, 2-236
  - Polar View, 2-178
- :View<x>:Marker:Peak
  - Analog View, 2-122
  - CDMA Time View, 2-251
  - CDMA Waveform View, 2-213
  - FSK View, 2-134
  - Spectrogram View, 2-145
  - Waterfall View, 2-160
  - Waveform View, 2-101
- :View<x>:Marker:ResetDelta
  - Analog View, 2-123
  - CCDF, 2-335
  - CCDFView, 2-349
  - CDMA Time View, 2-252
  - CDMA Waveform View, 2-213
  - CodePower View, 2-292
  - CodeSpectrogram View, 2-268
  - CodeWPower View, 2-324
  - CodeWSpectrogram View, 2-300
  - EVM View, 2-200
  - FSK View, 2-134
  - Spectrogram View, 2-145
  - Waterfall View, 2-161
  - Waveform View, 2-102
- :View<x>:Marker:SearchMax
  - Analog View, 2-123
  - CCDF, 2-336
  - CCDFView, 2-350
  - CDMA Time View, 2-252
  - CDMA Waveform View, 2-214
  - CodePower View, 2-292
  - CodeSpectrogram View, 2-269
  - CodeWPower View, 2-324
  - CodeWSpectrogram View, 2-301
  - EVM View, 2-200
  - FSK View, 2-134
  - Spectrogram View, 2-146
  - Waterfall View, 2-161
- Waveform View, 2-102
- :View<x>:Marker:SearchMin
  - Analog View, 2-124
  - CCDF, 2-336
  - CCDFView, 2-350
  - CDMA Time View, 2-253
  - CDMA Waveform View, 2-214
  - CodePower View, 2-293
  - CodeSpectrogram View, 2-269
  - CodeWPower View, 2-325
  - CodeWSpectrogram View, 2-301
  - EVM View, 2-201
  - FSK View, 2-135
  - Spectrogram View, 2-146
  - Waterfall View, 2-162
  - Waveform View, 2-103
- :View<x>:Marker:SearchSeparation (?)
  - Analog View, 2-124
  - CCDF, 2-337
  - CCDFView, 2-351
  - CDMA Time View, 2-253
  - CDMA Waveform View, 2-214
  - CodePower View, 2-293
  - CodeSpectrogram View, 2-270
  - CodeWPower View, 2-325
  - CodeWSpectrogram View, 2-302
  - FSK View, 2-135
  - Spectrogram View, 2-146
  - Waterfall View, 2-162
  - Waveform View, 2-103
- :View<x>:Marker:Symbol?, Symbol Table View, 2-193
- :View<x>:Marker:T (?)
  - CDMA Polar View, 2-236
  - CodePolar View, 2-281
  - CodeWPolar View, 2-313
  - Eye Diagram View, 2-189
  - Polar View, 2-178
  - Symbol Table View, 2-193
- :View<x>:Marker:T?
  - Spectrogram View, 2-147
  - Waterfall View, 2-163
- :View<x>:Marker:Trace (?), Waveform View, 2-104
- :View<x>:Marker:X (?)
  - Analog View, 2-125
  - CCDF, 2-337
  - CCDFView, 2-351
  - CDMA Time View, 2-254
  - CDMA Waveform View, 2-215
  - CodePower View, 2-294
  - CodeSpectrogram View, 2-270
  - CodeWPower View, 2-326
  - CodeWSpectrogram View, 2-302
  - EVM View, 2-201

- FSK View, 2–136
- Spectrogram View, 2–147
- Waterfall View, 2–163
- Waveform View, 2–104
- :View<x>:Marker:X?
  - CDMA Polar View, 2–237
  - Polar View, 2–179
- :View<x>:Marker:Y?
  - Analog View, 2–125
  - CDMA Polar View, 2–237
  - CDMA Time View, 2–254
  - CDMA Waveform View, 2–215
  - EVM View, 2–202
  - Eye Diagram View, 2–189
  - FSK View, 2–136
  - Polar View, 2–179
  - Spectrogram View, 2–148
  - Waterfall View, 2–164
  - Waveform View, 2–105
- :View<x>:Marker:Z (?)
  - CodeSpectrogram View, 2–271
  - CodeWSpectrogram View, 2–303
  - Spectrogram View, 2–148
  - Waterfall View, 2–164
- :View<x>:MarkerToFrame, CCDF, 2–338
- :View<x>:Mask:OffLeft (?), CDMA Time View, 2–255
- :View<x>:Mask:OffLevel (?), CDMA Time View, 2–255
- :View<x>:Mask:OffRight (?), CDMA Time View, 2–256
- :View<x>:Mask:OnLeft (?), CDMA Time View, 2–257
- :View<x>:Mask:OnLevel (?), CDMA Time View, 2–257
- :View<x>:Mask:OnRight (?), CDMA Time View, 2–258
- :View<x>:Mask:RBW1M:Frequency (?), CDMA Waveform View, 2–216
- :View<x>:Mask:RBW1M:Level (?), CDMA Waveform View, 2–216
- :View<x>:Mask:RBW30k:Frequency1 (?), CDMA Waveform View, 2–217
- :View<x>:Mask:RBW30k:Frequency2 (?), CDMA Waveform View, 2–217
- :View<x>:Mask:RBW30k:Level1 (?), CDMA Waveform View, 2–218
- :View<x>:Mask:RBW30k:Level2 (?), CDMA Waveform View, 2–218
- :View<x>:MaskArea (?), EVM View, 2–202
- :View<x>:MaskVisible (?), Waveform View, 2–105
- :View<x>:MeasDestination (?)
  - CDMA Polar View, 2–238
  - Polar View, 2–180
- :View<x>:MeasFilter (?)
  - CDMA Polar View, 2–238
  - CodePolar View, 2–282
  - CodeWPolar View, 2–314
  - Polar View, 2–180
- :View<x>:Measure, CDMA Time View, 2–259
- :View<x>:MeasureData, CDMA Time View, 2–259
- :View<x>:Measurement (?)
  - CDMA Waveform View, 2–219
  - Waveform View, 2–106
- :View<x>:Measurement:ACP:BW (?), Waveform View, 2–107
- :View<x>:Measurement:ACP:Marker (?), Waveform View, 2–107
- :View<x>:Measurement:ACP:SP (?), Waveform View, 2–108
- :View<x>:Measurement:OBW (?)
  - CDMA Waveform View, 2–219
  - Waveform View, 2–108
- :View<x>:Measurement:Separation (?), CDMA Waveform View, 2–220
- :View<x>:Measurement:SortedBy (?), CDMA Waveform View, 2–220
- :View<x>:Measurement:SpuriousSearch (?), CDMA Waveform View, 2–221
- :View<x>:Measurement:Threshold (?), CDMA Waveform View, 2–221
- :View<x>:Modulation (?)
  - CDMA Polar View, 2–239
  - CodePolar View, 2–282
  - CodeWPolar View, 2–314
  - Polar View, 2–181
- :View<x>:Monochrome (?)
  - CodeSpectrogram View, 2–271
  - CodeWSpectrogram View, 2–303
  - Spectrogram View, 2–148
- :View<x>:NumberColors (?)
  - CodeSpectrogram View, 2–272
  - CodeWSpectrogram View, 2–304
  - Spectrogram View, 2–149
- :View<x>:OutputFormat (?), CCDF, 2–338
- :View<x>:Position (?)
  - CCDF, 2–339
  - CDMA Polar View, 2–239
  - CDMA Time View, 2–260
  - CDMA Waveform View, 2–222
  - Polar View, 2–181
  - Waveform View, 2–109
- :View<x>:Radix (?), Symbol Table View, 2–194
- :View<x>:RBW (?), CDMA Waveform View, 2–222
- :View<x>:RefDestination (?)
  - CDMA Polar View, 2–240



- Polar View, 2-182
- :View<x>:RefFilter (?)
  - CDMA Polar View, 2-240
  - CodePolar View, 2-283
  - CodeWPolar View, 2-315
  - Polar View, 2-182
- :View<x>:Resolution (?), CCDF, 2-339
- :View<x>:Result<y>?
  - CDMA Polar View, 2-241
  - CDMA Time View, 2-260
  - CDMA Waveform View, 2-223
  - EVM View, 2-203
  - Polar View, 2-183
  - Waveform View, 2-109
- :View<x>:Result1?, CCDF, 2-340
- :View<x>:Result2?, CCDF, 2-340
- :View<x>:Result3?, CCDF, 2-341
- :View<x>:Rotate (?), Symbol Table View, 2-194
- :View<x>:Scale:AutoScale
  - Analog View, 2-126
  - CCDF, 2-341
  - CCDFView, 2-352
  - CDMA Waveform View, 2-224
  - CodePower View, 2-294
  - CodeSpectrogram View, 2-272
  - CodeWPower View, 2-326
  - CodeWSpectrogram View, 2-304
  - EVM View, 2-203
  - FSK View, 2-136
  - Spectrogram View, 2-149
  - Waterfall View, 2-165
  - Waveform View, 2-110
- :View<x>:Scale:FallingEdge, CDMA Time View, 2-261
- :View<x>:Scale:FullScale, CDMA Time View, 2-261
- :View<x>:Scale:HoldYScale (?)
  - Analog View, 2-126
  - CCDF, 2-342
  - CDMA Time View, 2-262
  - CDMA Waveform View commands, 2-224
  - FSK View, 2-137
  - Spectrogram View, 2-150
  - Waterfall View, 2-165
  - Waveform View, 2-110
- :View<x>:Scale:LYStart (?), CCDFView, 2-352
- :View<x>:Scale:LYStop (?), CCDFView, 2-353
- :View<x>:Scale:Origin (?)
  - CCDF, 2-342
  - CCDFView, 2-353
- :View<x>:Scale:RisingEdge, CDMA Time View, 2-262
- :View<x>:Scale:XScale (?)
  - Analog View, 2-127
  - CCDF, 2-343
  - CCDFView, 2-354
  - CDMA Time View, 2-263
  - CDMA Waveform View, 2-225
  - CodePower View, 2-295
  - CodeSpectrogram View, 2-273
  - CodeWPower View, 2-327
  - CodeWSpectrogram View, 2-305
  - EVM View, 2-204
  - FSK View, 2-137
  - Spectrogram View, 2-150
  - Waterfall View, 2-166
  - Waveform View, 2-111
- :View<x>:Scale:XStart (?)
  - Analog View, 2-127
  - CCDF, 2-343
  - CCDFView, 2-354
  - CDMA Time View, 2-263
  - CDMA Waveform View, 2-225
  - CodePower View, 2-295
  - CodeSpectrogram View, 2-273
  - CodeWPower View, 2-327
  - CodeWSpectrogram View, 2-305
  - EVM View, 2-204
  - FSK View, 2-138
  - Spectrogram View, 2-151
  - Waterfall View, 2-166
  - Waveform View, 2-111
- :View<x>:Scale:XStartZero (?), CCDF, 2-344
- :View<x>:Scale:YScale (?)
  - Analog View, 2-128
  - CCDF, 2-344
  - CDMA Time View, 2-264
  - CDMA Waveform View, 2-226
  - CodePower View, 2-296
  - CodeSpectrogram View, 2-274
  - CodeWPower View, 2-328
  - CodeWSpectrogram View, 2-306
  - EVM View, 2-205
  - FSK View, 2-138
  - Spectrogram View, 2-151
  - Waterfall View, 2-167
  - Waveform View, 2-112
- :View<x>:Scale:YStart (?)
  - Analog View, 2-128
  - CCDF, 2-345
  - CDMA Time View, 2-264
  - CDMA Waveform View, 2-226
  - CodePower View, 2-296
  - CodeSpectrogram View, 2-274
  - CodeWPower View, 2-328
  - CodeWSpectrogram View, 2-306
  - EVM View, 2-205

- FSK View, 2-139
- Spectrogram View, 2-152
- Waterfall View, 2-167
- Waveform View, 2-112
- :View<x>:Scale:ZScale (?)
  - CodeSpectrogram View, 2-275
  - CodeWSpectrogram View, 2-307
  - Spectrogram View, 2-152
  - Waterfall View, 2-168
- :View<x>:Scale:ZStart (?)
  - CodeSpectrogram View, 2-275
  - CodeWSpectrogram View, 2-307
  - Spectrogram View, 2-153
  - Waterfall View, 2-168
- :View<x>:ShortCode (?)
  - CodeWPolar View, 2-315
  - CodeWPower View, 2-328
- :View<x>:Source (?)
  - Analog View, 2-129
  - CCDF, 2-345
  - CCDFView, 2-355
  - CDMA Polar View, 2-241
  - CDMA Time View, 2-265
  - CDMA Waveform View, 2-227
  - CodePolar View, 2-283
  - CodeWPolar View, 2-316
  - Eye Diagram View, 2-190
  - FSK View, 2-139
  - Polar View, 2-183
  - Spectrogram View, 2-153
  - Symbol Table View, 2-195
  - Waterfall View, 2-169
  - Waveform View, 2-113
- :View<x>:Standard:CDPD
  - CDMA Polar View, 2-242
  - Polar View, 2-184
- :View<x>:Standard:GSM
  - CDMA Polar View, 2-242
  - Polar View, 2-184
- :View<x>:Standard:IS95
  - CDMA Polar View, 2-242
  - CodePolar View, 2-284
- :View<x>:Standard:IS95EQ, CodePolar View, 2-284
- :View<x>:Standard:NADC
  - CDMA Polar View, 2-243
  - Polar View, 2-184
- :View<x>:Standard:PDC
  - CDMA Polar View, 2-243
  - Polar View, 2-185
- :View<x>:Standard:PHS
  - CDMA Polar View, 2-243
  - Polar View, 2-185
- :View<x>:Standard:TETRA
  - CDMA Polar View, 2-244
  - Polar View, 2-185
- :View<x>:Standard:WCDMA16M, CodeWPolar View, 2-316
- :View<x>:Standard:WCDMA4M, CodeWPolar View, 2-316
- :View<x>:Standard:WCDMA8M, CodeWPolar View, 2-317
- :View<x>:SymbolConstellation (?), CodeWPolar View, 2-317
- :View<x>:SymbolRate (?)
  - CDMA Polar View, 2-244
  - CodePolar View, 2-285
  - CodeWPolar View, 2-318
  - CodeWPower View, 2-329
  - CodeWSpectrogram View, 2-308
  - Polar View, 2-186
- :View<x>:TimeSlot (?), CodeWPolar View, 2-318
- :View<x>:Trace2:Compression (?), Waveform View, 2-114
- :View<x>:Trace2:Format (?), Waveform View, 2-115
- :View<x>:Trace2:Source (?), Waveform View, 2-116
- :View<x>:Trace2:TraceVisible (?), CDMA Time View, 2-265
- :View<x>:Trace2:Z (?), Waveform View, 2-116
- :View<x>:TraceVisible (?), CDMA Time View, 2-266
- :View<x>:Version?
  - Analog View, 2-129
  - CCDF, 2-346
  - CCDFView, 2-355
  - CDMA Polar View, 2-244
  - CDMA Time View, 2-266
  - CDMA Waveform View, 2-228
  - CodePolar View, 2-285
  - CodePower View, 2-297
  - CodeSpectrogram View, 2-276
  - CodeWPolar View, 2-318
  - CodeWPower View, 2-329
  - CodeWSpectrogram View, 2-308
  - EVM View, 2-206
  - Eye Diagram View, 2-190
  - FSK View, 2-140
  - Polar View, 2-186
  - Spectrogram View, 2-154
  - Symbol Table View, 2-196
  - Waterfall View, 2-169
  - Waveform View, 2-117
- :View<x>:XAxis (?), CodeWPower View, 2-330
- :View<x>:YHeight (?), Waterfall View, 2-170
- :View<x>:Z (?)
  - Analog View, 2-130
  - CCDF, 2-346
  - CDMA Polar View, 2-245

CDMA Waveform View, 2–228  
 CodePower View, 2–297  
 CodeWPower View, 2–330  
 FSK View, 2–140  
 Polar View, 2–186  
 Waveform View, 2–117  
 :View<x>:ZGap (?)  
   CodeSpectrogram View, 2–276  
   CodeWSpectrogram View, 2–308  
   Spectrogram View, 2–154  
   Waterfall View, 2–170

## W

### Waterfall View commands

:View<x>:Compression (?), 2–156  
 :View<x>:Format (?), 2–157  
 :View<x>:Marker:DeltaMarker (?), 2–158  
 :View<x>:Marker:DeltaT?, 2–158  
 :View<x>:Marker:DeltaX (?), 2–159  
 :View<x>:Marker:DeltaY?, 2–159  
 :View<x>:Marker:DeltaZ (?), 2–160  
 :View<x>:Marker:Peak, 2–160  
 :View<x>:Marker:ResetDelta, 2–161  
 :View<x>:Marker:SearchMax, 2–161  
 :View<x>:Marker:SearchMin, 2–162  
 :View<x>:Marker:SearchSeparation (?), 2–162  
 :View<x>:Marker:T?, 2–163  
 :View<x>:Marker:X (?), 2–163  
 :View<x>:Marker:Y?, 2–164  
 :View<x>:Marker:Z (?), 2–164  
 :View<x>:Scale:AutoScale, 2–165  
 :View<x>:Scale:HoldYScale (?), 2–165  
 :View<x>:Scale:XScale (?), 2–166  
 :View<x>:Scale:XStart (?), 2–166  
 :View<x>:Scale:YScale (?), 2–167  
 :View<x>:Scale:YStart (?), 2–167  
 :View<x>:Scale:ZScale (?), 2–168  
 :View<x>:Scale:ZStart (?), 2–168  
 :View<x>:Source (?), 2–169  
 :View<x>:Version?, 2–169  
 :View<x>:YHeight (?), 2–170  
 :View<x>:ZGap (?), 2–170

### Waveform View commands

:View<x>:Average:Times (?), 2–92  
 :View<x>:Average:Type (?), 2–92  
 :View<x>:Compression (?), 2–93

:View<x>:CopyFrom, 2–93  
 :View<x>:CopyTo, 2–94  
 :View<x>:Edit (?), 2–94  
 :View<x>:Edit:DrawHorizontal, 2–95  
 :View<x>:Edit:DrawLine, 2–95  
 :View<x>:Edit:DrawMax, 2–96  
 :View<x>:Edit:DrawMin, 2–96  
 :View<x>:Edit:Y (?), 2–96  
 :View<x>:Format (?), 2–97  
 :View<x>:Marker:Band:Center (?), 2–98  
 :View<x>:Marker:Band:Left (?), 2–98  
 :View<x>:Marker:Band:Right (?), 2–99  
 :View<x>:Marker:Band:Width (?), 2–99  
 :View<x>:Marker:DeltaMarker (?), 2–100  
 :View<x>:Marker:DeltaX (?), 2–100  
 :View<x>:Marker:DeltaY?, 2–101  
 :View<x>:Marker:Peak, 2–101  
 :View<x>:Marker:ResetDelta, 2–102  
 :View<x>:Marker:SearchMax, 2–102  
 :View<x>:Marker:SearchMin, 2–103  
 :View<x>:Marker:SearchSeparation (?), 2–103  
 :View<x>:Marker:Trace (?), 2–104  
 :View<x>:Marker:X (?), 2–104  
 :View<x>:Marker:Y?, 2–105  
 :View<x>:MaskVisible (?), 2–105  
 :View<x>:Measurement (?), 2–106  
 :View<x>:Measurement:ACP:BW (?), 2–107  
 :View<x>:Measurement:ACP:Marker (?), 2–107  
 :View<x>:Measurement:ACP:SP (?), 2–108  
 :View<x>:Measurement:OBW (?), 2–108  
 :View<x>:Position (?), 2–109  
 :View<x>:Result<y>?, 2–109  
 :View<x>:Scale:AutoScale, 2–110  
 :View<x>:Scale:HoldYScale (?), 2–110  
 :View<x>:Scale:XScale (?), 2–111  
 :View<x>:Scale:XStart (?), 2–111  
 :View<x>:Scale:YScale (?), 2–112  
 :View<x>:Scale:YStart (?), 2–112  
 :View<x>:Source (?), 2–113  
 :View<x>:Trace2:Compression (?), 2–114  
 :View<x>:Trace2:Format (?), 2–115  
 :View<x>:Trace2:Source (?), 2–116  
 :View<x>:Trace2:Z (?), 2–116  
 :View<x>:Version?, 2–117  
 :View<x>:Z (?), 2–117

Where to find other information, vii





